

## Foreword

E09200108221

Thank you for selecting a MITSUBISHI MOTORS product as your new vehicle.

This owner's manual will add to your understanding and full enjoyment of the many fine features of this vehicle.

It contains information prepared to acquaint you with the proper way to operate and maintain your vehicle for the utmost in driving pleasure.

MITSUBISHI MOTORS CORPORATION reserves the right to make changes in design and specifications and/or to make additions to or improvements in this product without obligation to install them on products previously manufactured.

It is an absolute requirement for the driver to strictly observe all laws and regulations concerning vehicles.

This owner's manual has been written in compliance with such laws and regulations, but some of the contents may become contradictory with later amendment of the laws and regulations.

If your vehicle is equipped with any locally produced part, the operating procedure, specifications, maintenance intervals and other contents found in this owner's manual may not sometimes apply to it.

Please leave this owner's manual in this vehicle at time of resale. The next owner will appreciate having access to the information contained in this owner's manual.



Throughout this owner's manual the words **WARNING** and **CAUTION** appear. These serve as reminders to be especially careful. Failure to follow instructions could result in personal injury or damage to your vehicle.

### **WARNING**

**Indicates a strong possibility of severe personal injury or death if instructions are not followed.**

### **CAUTION**

**Means hazards or unsafe practices that could cause minor personal injury or damage to your vehicle.**

You will see another important symbol:

### **NOTE**

**Gives helpful information.**

**\*: Indicates optional equipment.**

It may differ according to the sales classification; refer to the sales catalogue.

Abbreviations used in this owner's manual:

**M/T: Manual Transmission**

**A/T: Automatic Transmission**

The symbol used on the vehicles:

: See owner's manual

- Please understand that the information in this manual may not pertain exactly to your vehicle due to differences in equipment specifications, etc.
- If you have any questions, please contact the sales staff in charge.

## **Table of contents**

<b>Overview/Quick guide</b>	<b>1</b>
<b>General information</b>	<b>2</b>
<b>Locking and unlocking</b>	<b>3</b>
<b>Seat and seat belts</b>	<b>4</b>
<b>Instruments and controls</b>	<b>5</b>
<b>Starting and driving</b>	<b>6</b>
<b>For pleasant driving</b>	<b>7</b>
<b>For emergencies</b>	<b>8</b>
<b>Vehicle care</b>	<b>9</b>
<b>Maintenance</b>	<b>10</b>
<b>Specifications</b>	<b>11</b>
<b>Alphabetical index</b>	<b>12</b>



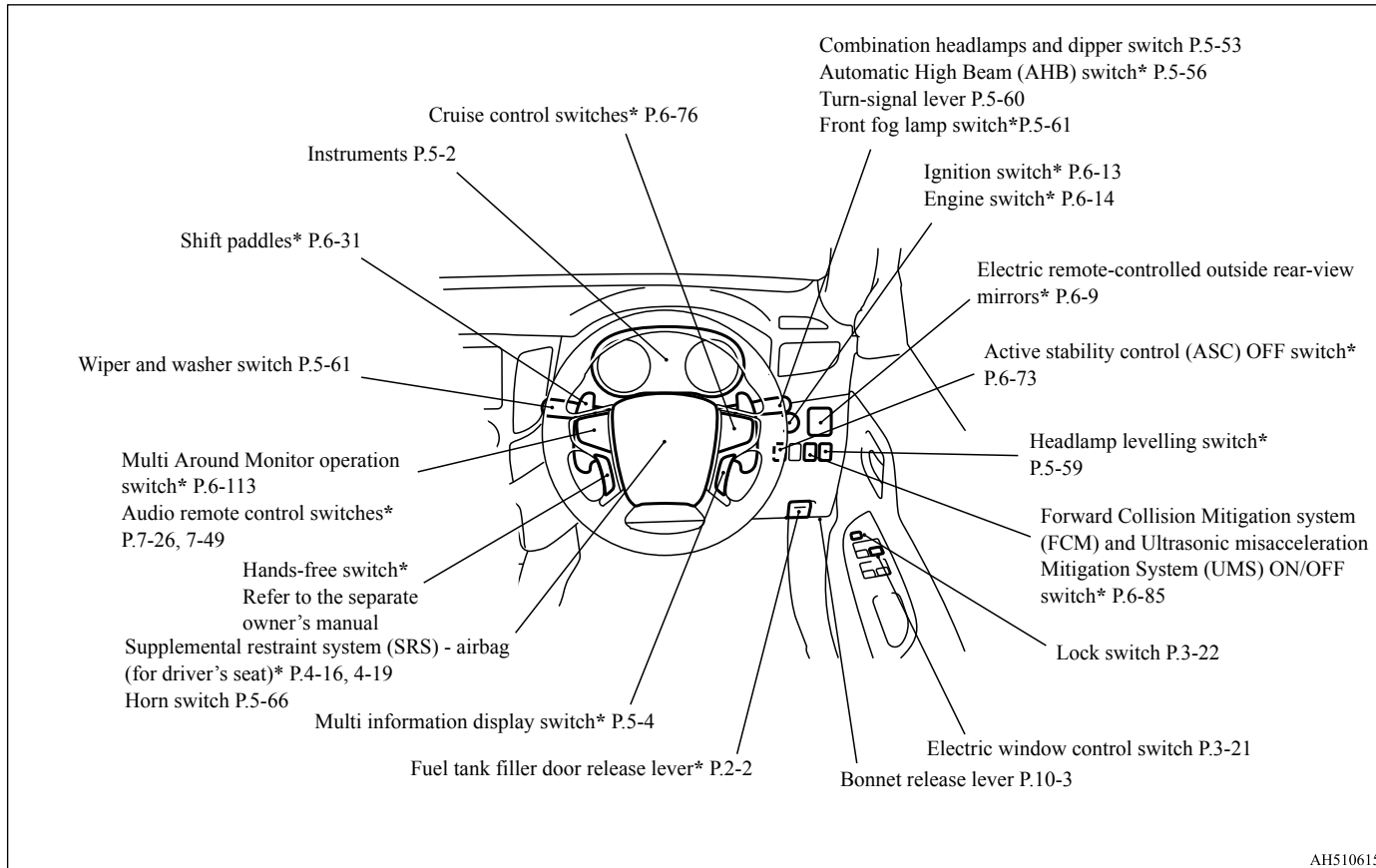

**Instruments and Controls**

E08500103020

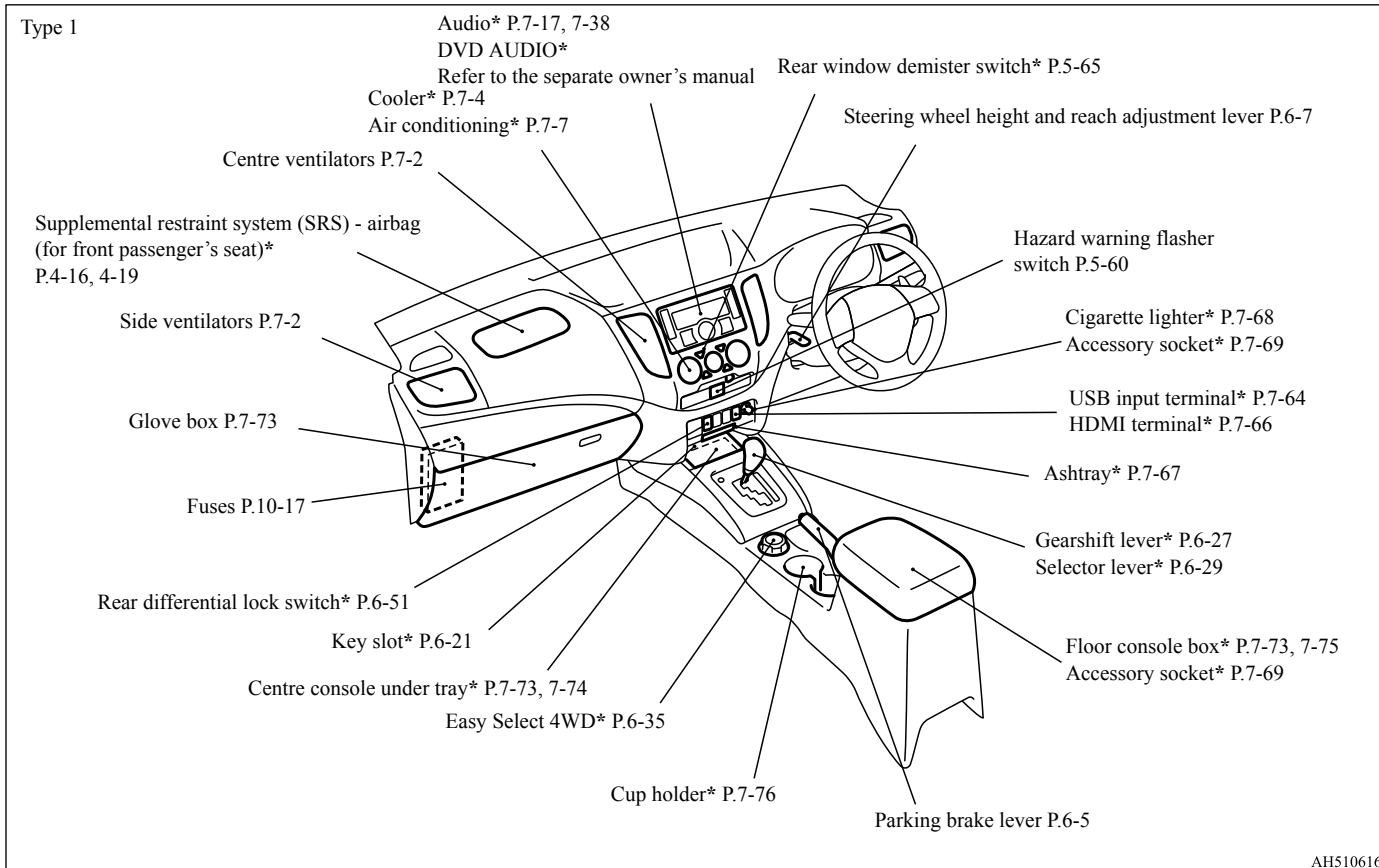

Instruments and Controls

1

Type 2

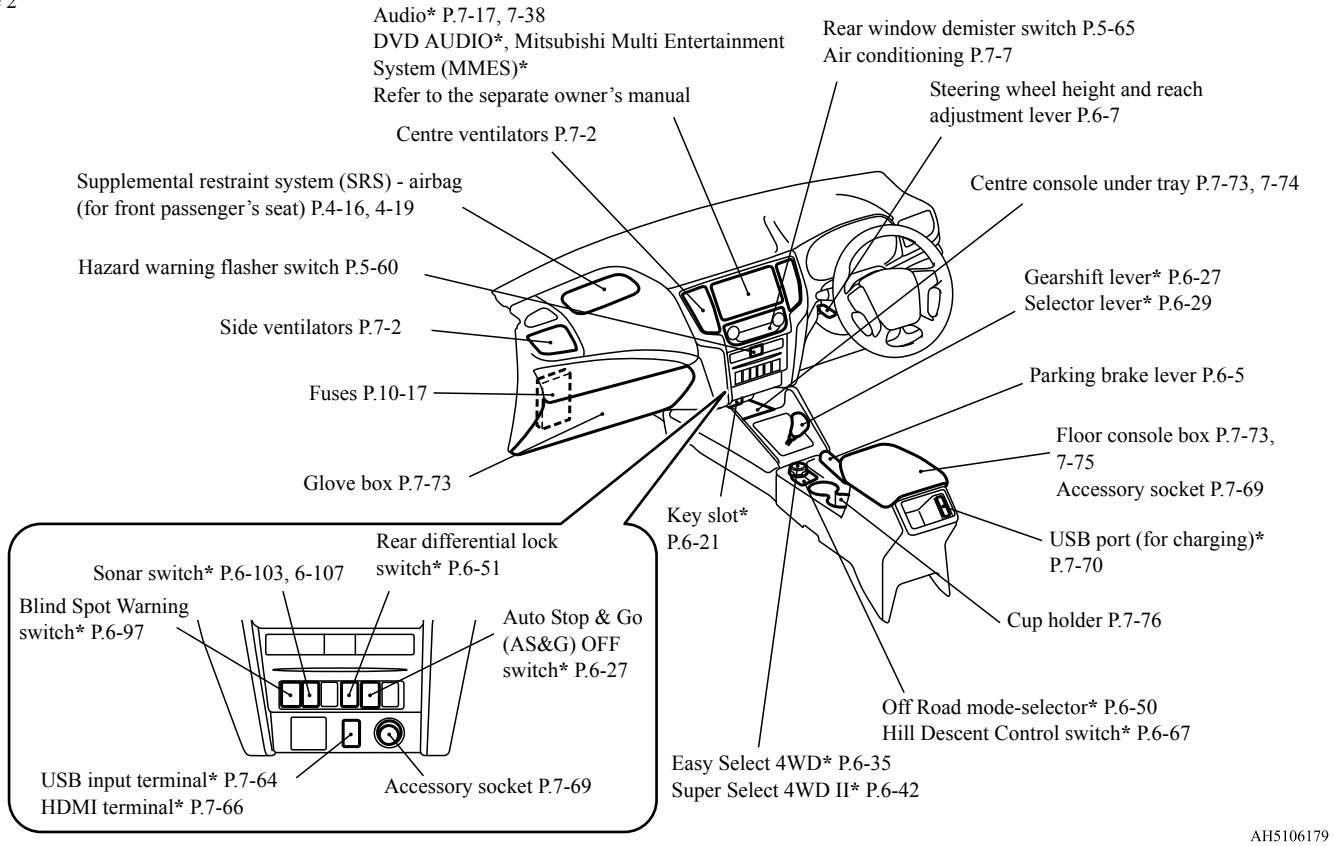

AH5106179

Interior

E08500202431

Single cab

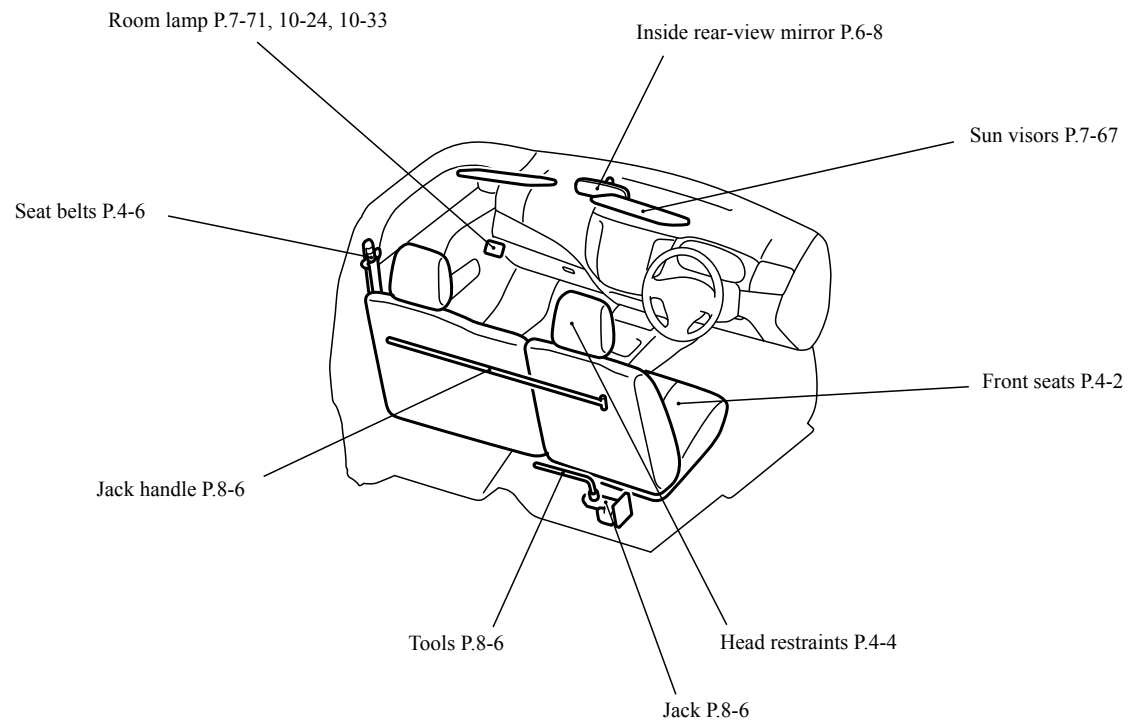

AH5106182

## Interior

1

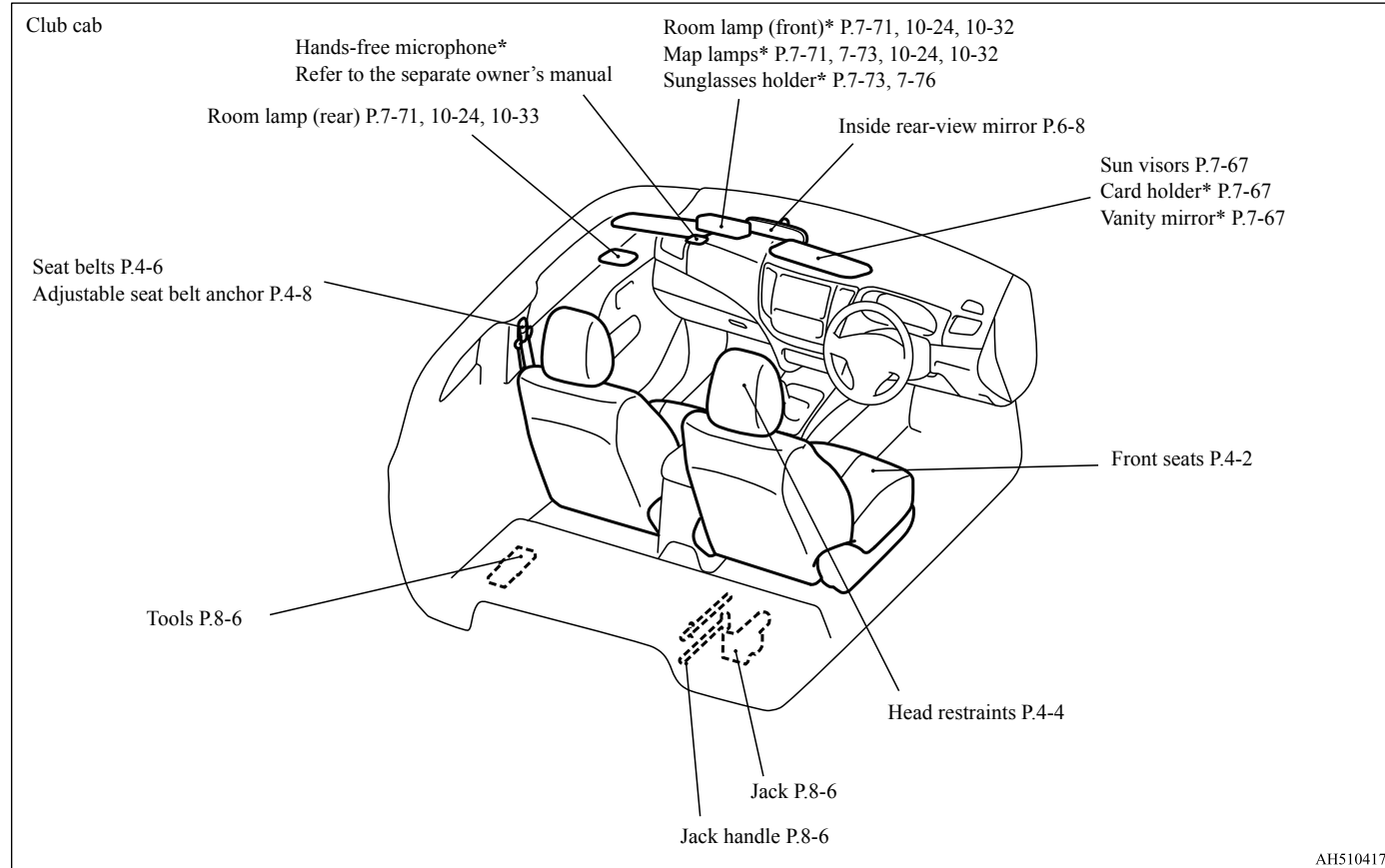

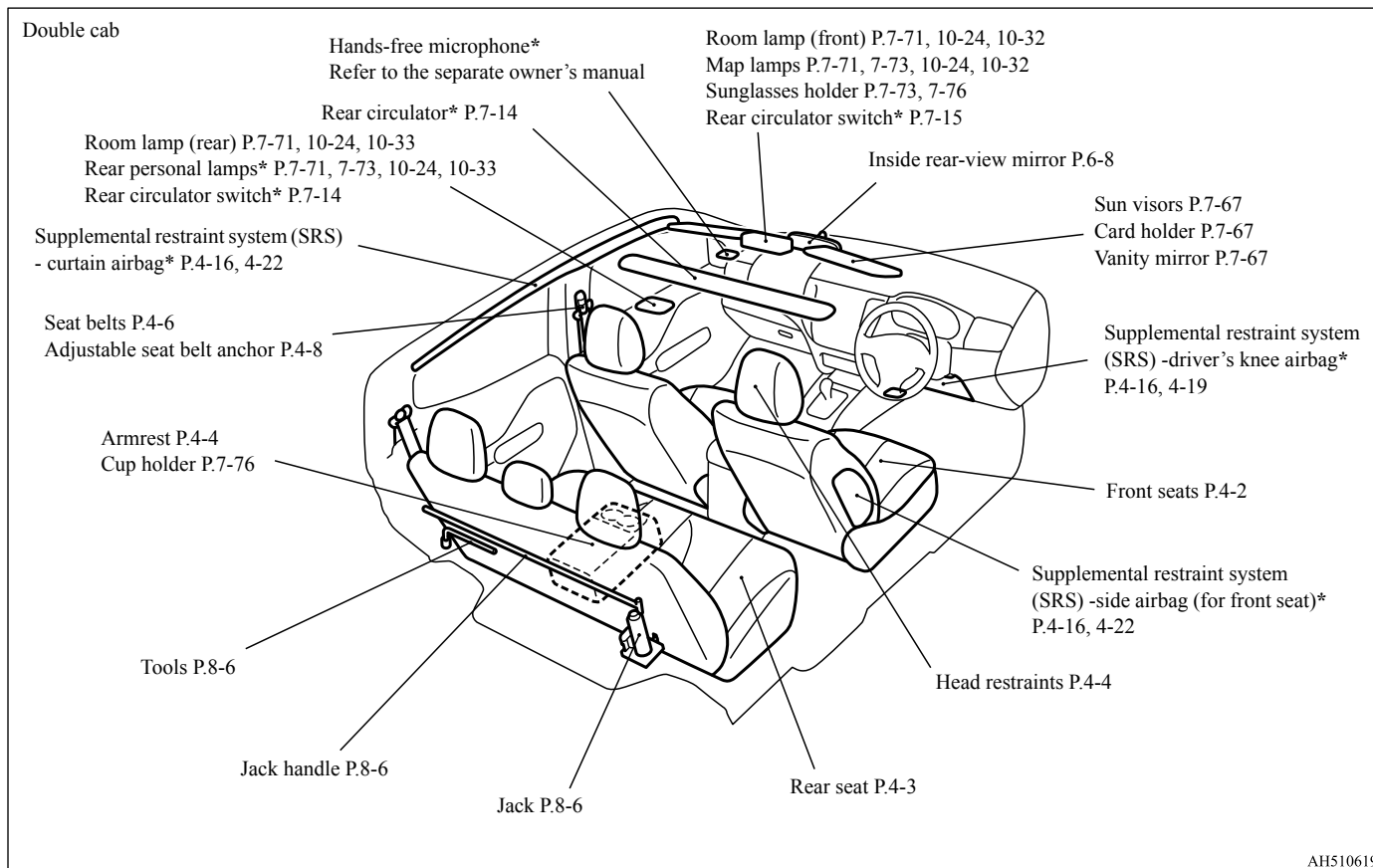

**1 Exterior - front**

E08500403485

Single cab

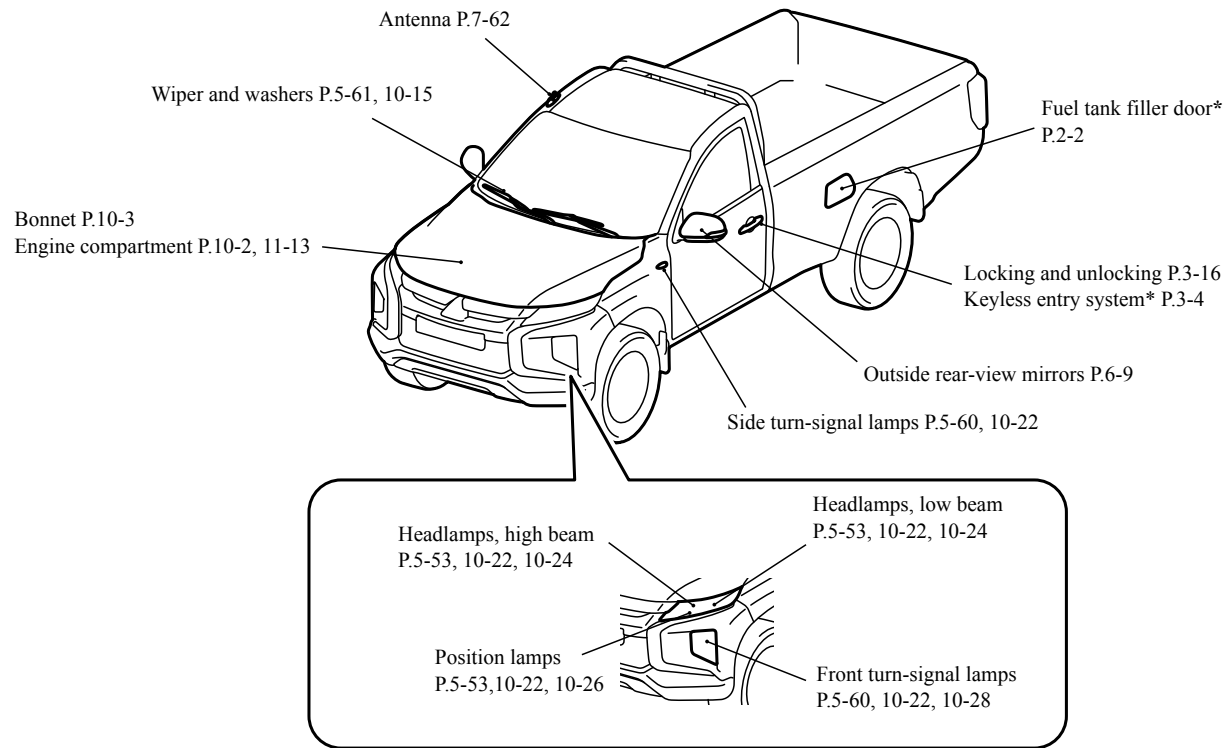

AH5106209

Club cab

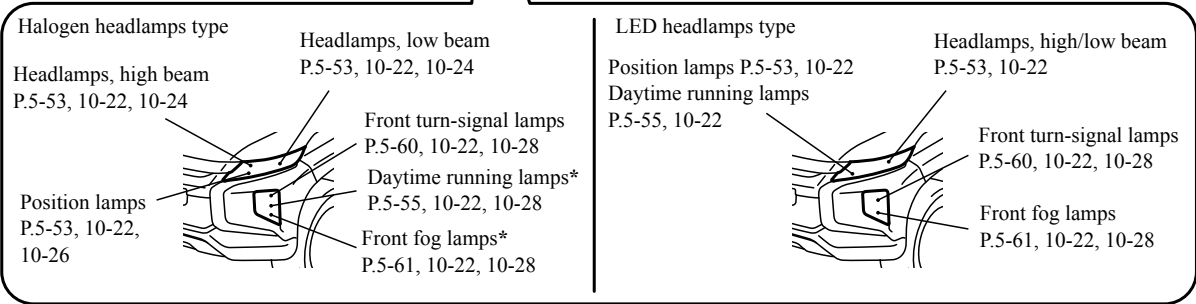
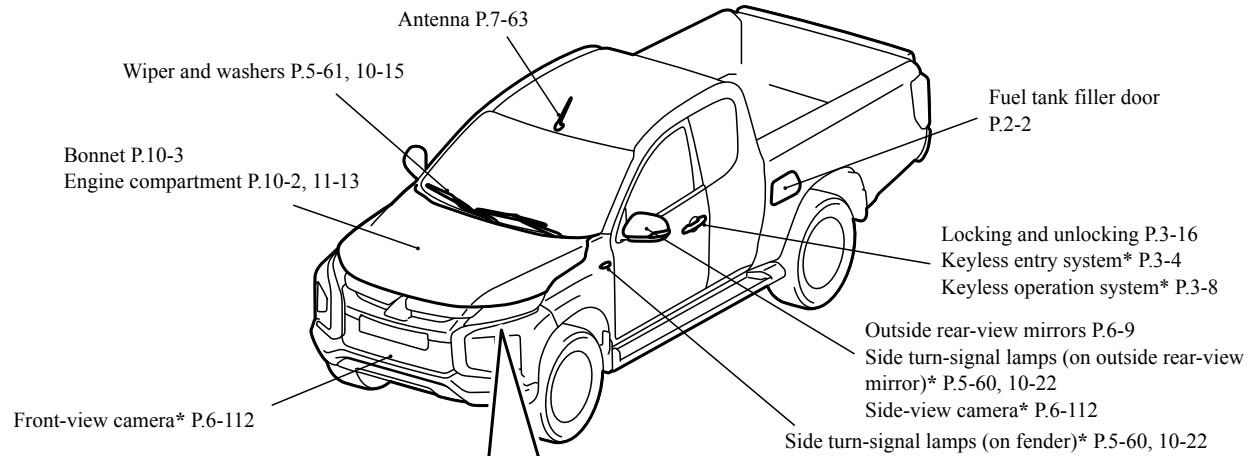

AH5107189



Exterior - front

1

Double cab

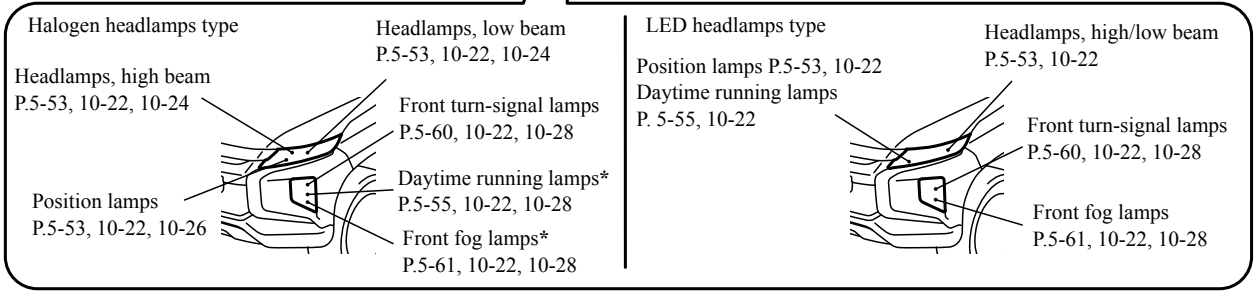
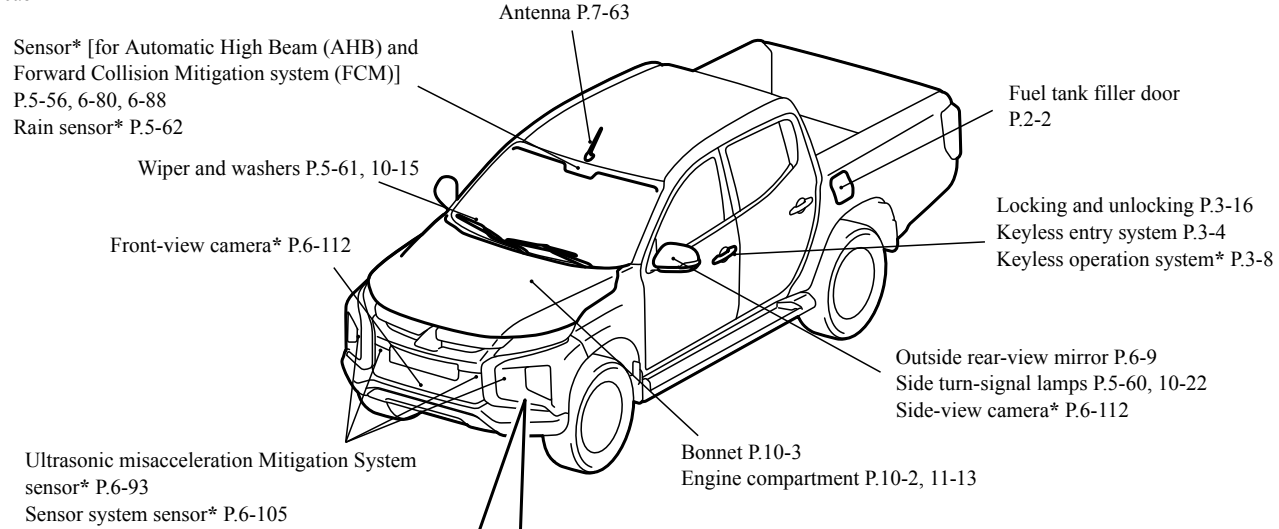

AH5106241

Exterior - rear

1

E08500403498

Single cab

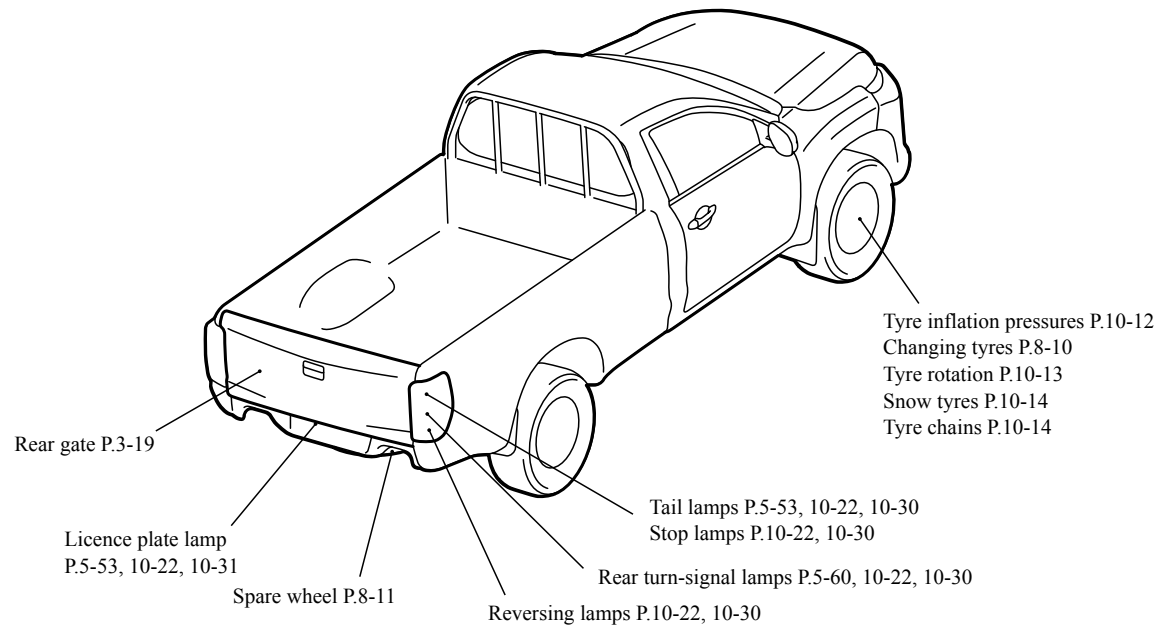

AH5106254

Exterior - rear

1

Club cab

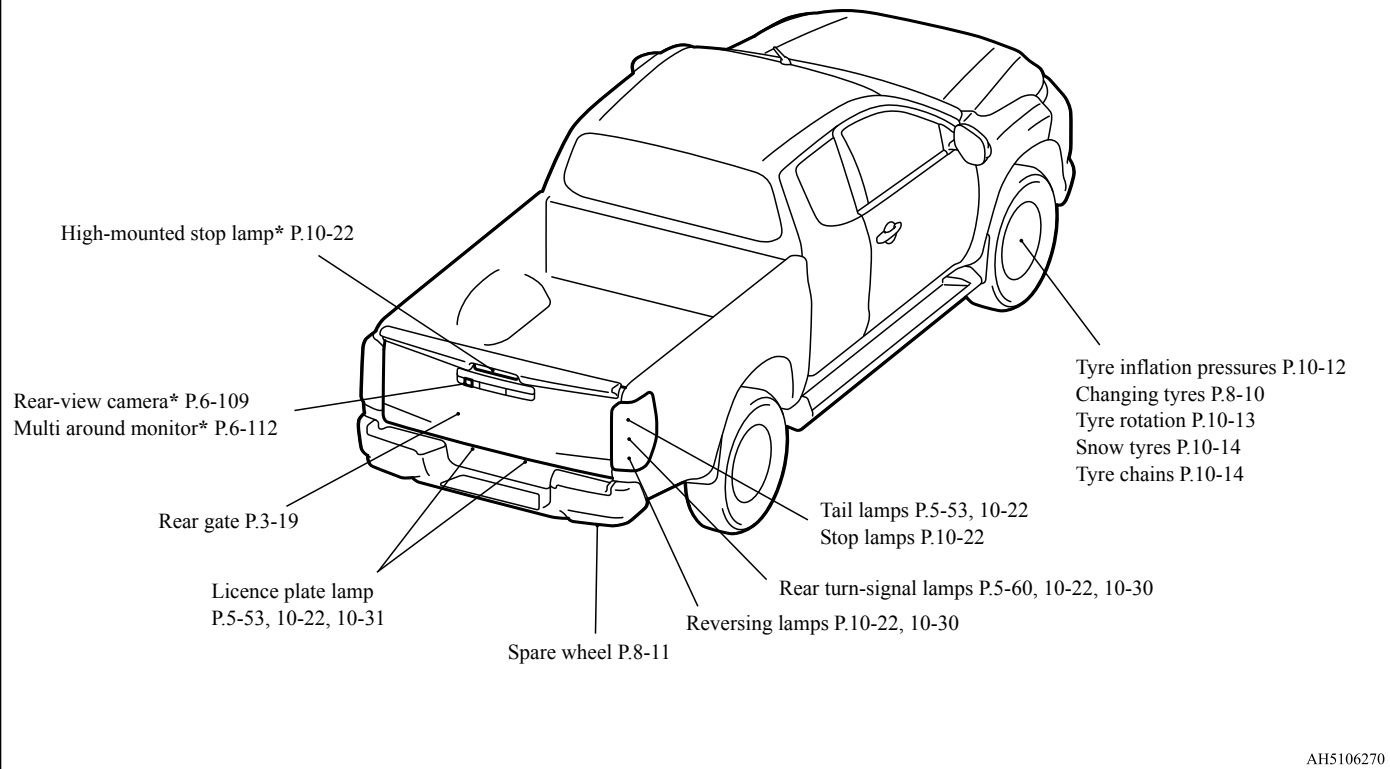

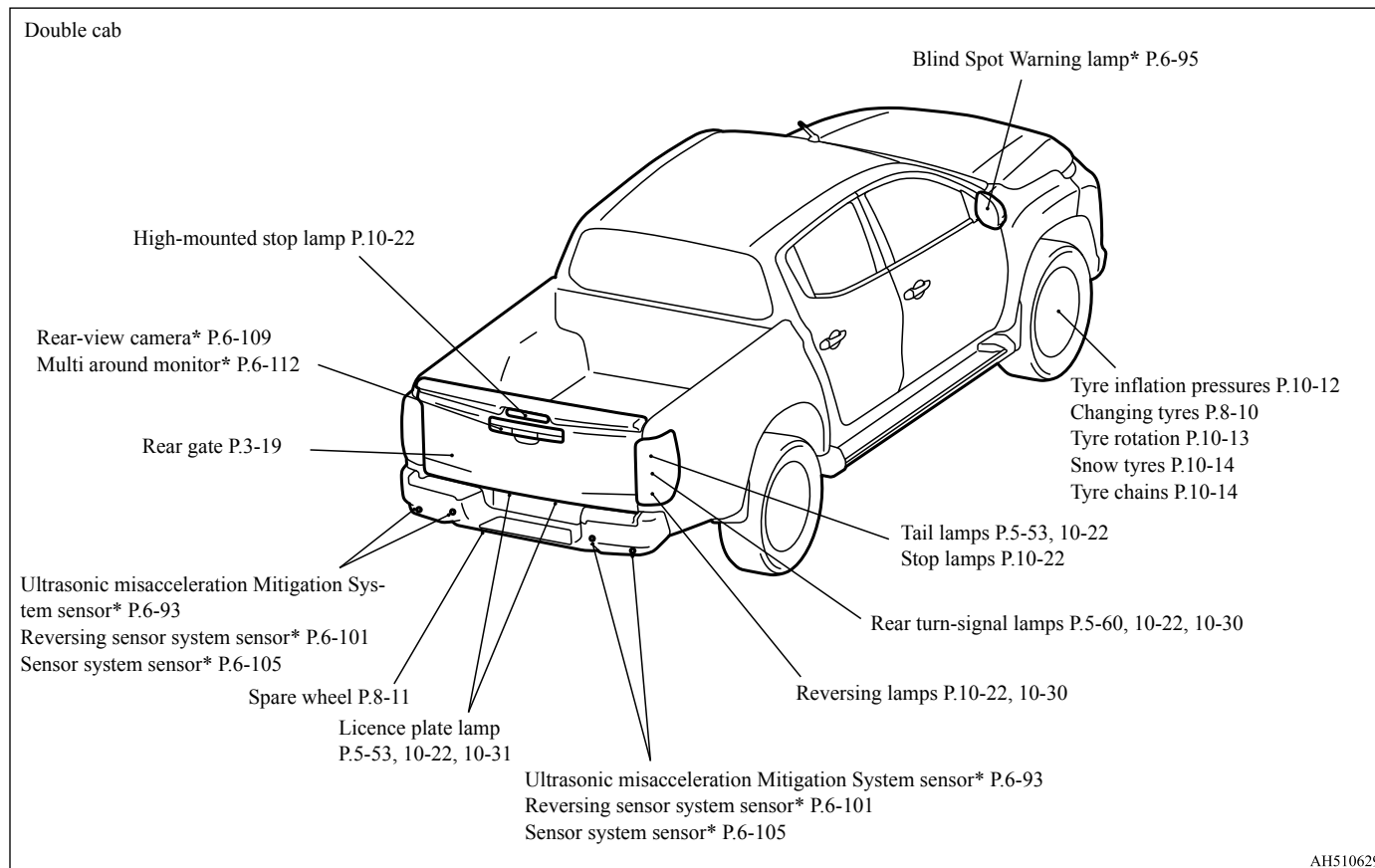

1

Quick guide

E08500500010

Lock and unlock the doors

E08500602132

Keyless entry system\*

Press the key switch, and all doors will be locked or unlocked as desired.

It is also possible to operate the outside rear-view mirrors. (Vehicles equipped with the mirror retractor switch)

The key switch will operate within approximately 4 m from the vehicle.

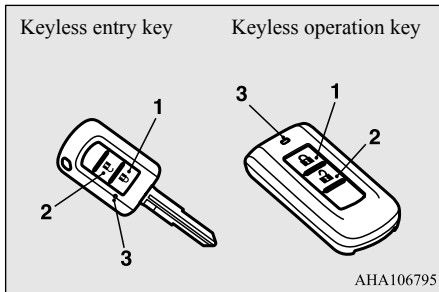

AHA106795

- 1- LOCK switch
- 2- UNLOCK switch
- 3- Indicator lamp

Refer to “Keyless entry system” on page 3-4.

For vehicles equipped with the mirror retractor switch, the outside rear-view mirrors can be retracted and extended automatically if you press the LOCK switch (1) or UNLOCK switch (2).

Refer to “Operation of the outside rear-view mirrors” on page 3-5.

Keyless operation system\*

When you are carrying the keyless operation key and within the operating range, if you press the driver’s or front passenger’s door lock/unlock switch (A), the doors are locked/unlocked.

The operating range is approximately 70 cm from the driver’s or front passenger’s door lock/unlock switch.

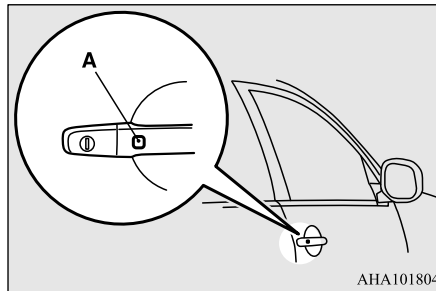

AHA101804

Refer to “keyless operation system” on page 3-8.

Around the driver’s seat

E08500802235

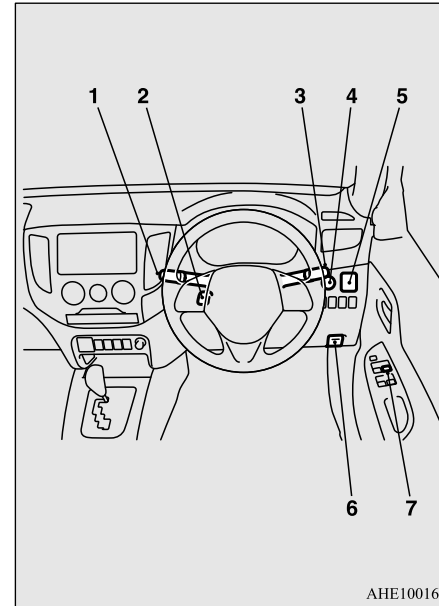

AHE100166

## 1-Wiper and washer switch

### ■ Except for vehicles equipped with rain sensor

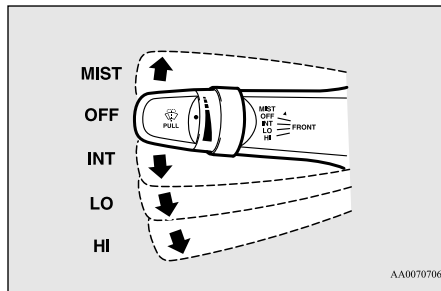

- MIST- Misting function  
The wipers will operate once.
- OFF- Off
- INT- Intermittent (Speed sensitive)
- LO- Slow
- HI- Fast

### ■ Vehicles equipped with rain sensor

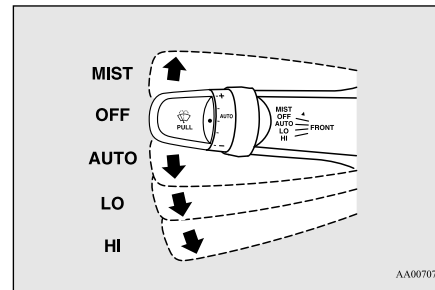

- MIST- Misting function  
The wipers will operate once.
- OFF- Off
- AUTO- Auto-wiper control  
Rain sensor  
The wipers will automatically operate depending on the degree of wetness on the windscreen.
- LO- Slow
- HI- Fast

The washer fluid will be sprayed onto the windscreen by pulling the lever towards you.

Refer to “Wiper and washer switch” on page 5-61.

## 2-Steering wheel height and reach adjustment

1. Release the lever while holding the steering wheel up.
2. Adjust the steering wheel to the desired position.
3. Securely lock the steering wheel by pulling the lever fully upward.

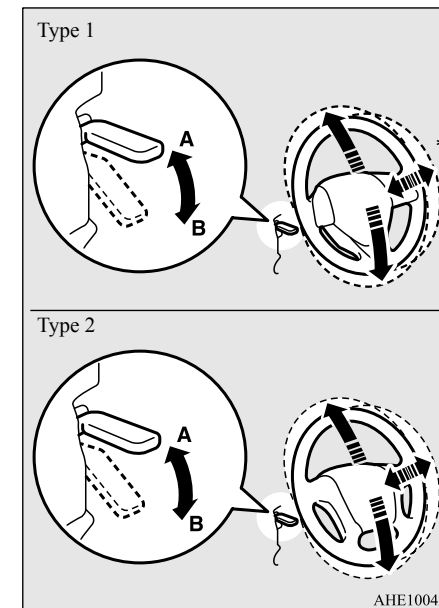

A- Locked

## Quick guide

**1**

B- Release

\*: Vehicles equipped with the reach adjustment

Refer to “Steering wheel height and reach adjustment” on page 6-7.

### 3-Combination headlamps

Rotate the switch to turn on the lamps.

#### Type 1

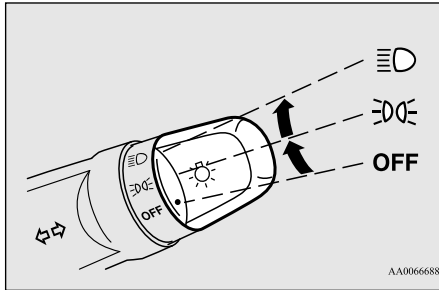

OFF	All lamps off
AUTO	Position, tail, licence plate, instrument panel lamps on
ON	Headlamps and other lamps go on

#### Type 2

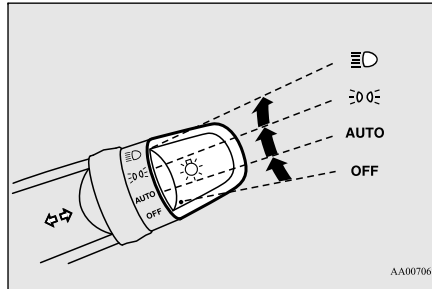

OFF	All lamps off
AUTO	With the ignition switch or the operation mode is in ON, headlamps, position, tail, licence plate and instrument panel lamps turn on and off automatically in accordance with outside light level. All lamps turn off automatically when the ignition switch is turned to “OFF” position or the operation mode is put in OFF.
AUTO	Position, tail, licence plate and instrument panel lamps on
ON	Headlamps and other lamps go on

Refer to “Combination headlamps and dipper switch” on page 5-53.

### 3-Turn-signal lever

The turn-signal lamps flash when the lever is operated.

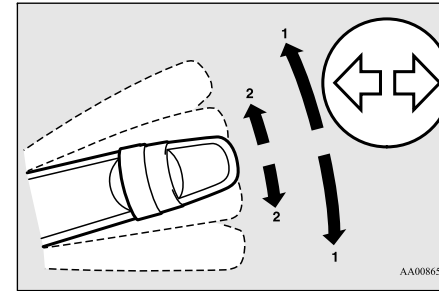

- 1- Turn-signals
- 2- Lane-change signals

Refer to “Turn-signal lever” on page 5-60.

### 4-Engine switch\*

If you are carrying the keyless operation key, you can start the engine. If you press the engine switch without depressing the brake pedal (A/T) or the clutch pedal (M/T), you can change the operation mode in the order of OFF, ACC, ON, OFF.

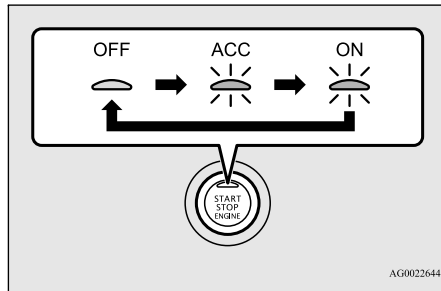

AG0022644

- OFF- The indicator lamp on the engine switch turns off.
- ACC- The indicator lamp on the engine switch illuminates orange.
- ON- The indicator lamp on the engine switch illuminates green.

Refer to “Engine switch” on page 6-14.

### 5-Electric remote-controlled outside rear-view mirrors\*

To adjust the mirror position

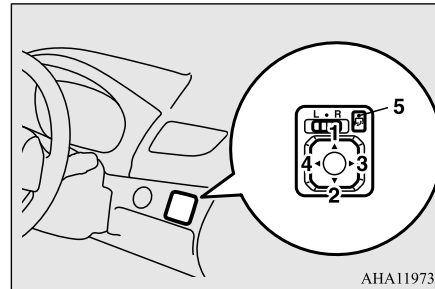

AHA119731

- L- Left outside mirror adjustment
- R- Right outside mirror adjustment
- 1- Up
- 2- Down
- 3- Right
- 4- Left
- 5- Mirror retractor switch

Refer to “Outside rear-view mirrors” on page 6-9.

### 6-Fuel tank filler door release lever\*

Open the fuel tank filler door.  
The fuel tank filler is located on the rear left side of your vehicle.

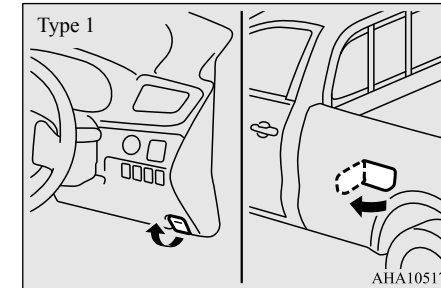

AHA105176

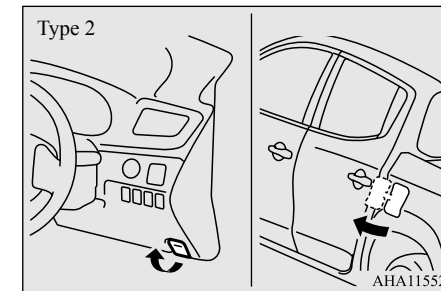

AHA115528

Refer to “Filling the fuel tank” on page 2-2.



## 1 7-Electric window control

Press the switch down for opening the window, and pull the switch for closing.

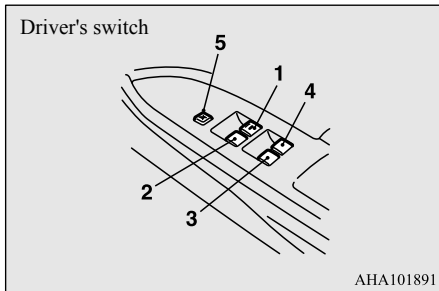

- 1- Driver's door window
- 2- Front passenger's door window
- 3- Rear left door window (Double cab)
- 4- Rear right door window (Double cab)
- 5- Lock switch

### Lock switch

If you press the switch (5), the passenger's switches cannot be operated. To cancel, press it once again.

Refer to "Electric window control" on page 3-21.

## Automatic transmission Sports Mode 6A/T

E08501001686

### Selector lever operation

The transmission selects an optimum gear automatically, depending on the speed of the vehicle and the position of the accelerator pedal.

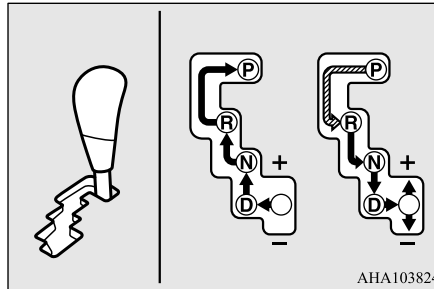

⬇	While depressing the brake pedal, move the selector lever through the gate.
⬇	Move the selector lever through the gate.

### Selector lever positions

#### "P" PARK

This position locks the transmission to prevent the vehicle from moving. The engine can be started in this position.

#### "R" REVERSE

This position is to back up.

#### "N" NEUTRAL

At this position the transmission is disengaged.

#### "D" DRIVE

This position is for normal driving.

Refer to "Automatic transmission Sports Mode 6A/T" on page 6-29.

**4-wheel drive operation\*****1**

E08502000123

Driving mode	Road conditions					
	Dry paved road and highway	Packed snow road	Gravel road	Deep snow or muddy road	Sandy road	Rocky road
Easy Select 4WD (→ P.6-35)	2H	4H	4H or 4L	4H or 4L	4H or 4L	4H or 4L
Super Select 4WD II (→ P.6-42)	2H or 4H	4H	4HLc or 4LLc	4HLc or 4LLc	4HLc or 4LLc	4HLc or 4LLc
Off Road mode-selector (→ P.6-50)	–	–	GRAVEL	MUD/SNOW	SAND	ROCK
Rear differential lock (→ P.6-51)	–	–	–	Active*	Active*	Active*

\*:The Off Road mode and the rear differential lock cannot be used at the same time. When the rear differential lock is set to ON, the Off Road mode turns off. In addition, when the rear differential lock is ON, the Off Road mode will be deactivated even if the Off Road mode-selector is operated.

**⚠ CAUTION**

- When driving on the off-road, confirm the conditions of the road surface and the landscape, and drive after confirming that the components of the suspension and the bottom of the front and rear bumper do not contact with the road surface. (Refer to “Vehicle dimensions” on page 11-3)

## Quick guide

### 1 Multi information display

E08501201604

Always stop the vehicle in a safe place before operating.

The following information is included on the multi information display: odometer, tripmeter, average fuel consumption etc.

#### Type 1

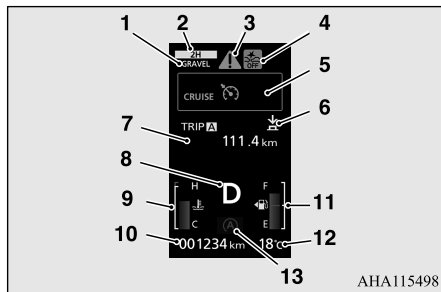

AHA115498

- 1- Off Road mode indicator display\*  
→ P.6-50
- 2- Drive mode indicator display\*  
(Vehicles with Easy Select 4WD)  
→ P.6-36  
(Vehicles with Super Select 4WD II)  
→ P.6-43
- 3- mark display → P.5-6

- 4- Forward Collision Mitigation system (FCM) OFF indicator display\*  
→ P.6-80
- Ultrasonic misacceleration Mitigation System (UMS) OFF indicator display\*  
→ P.6-90
- 5- Cruise control indicator display\*  
→ P.6-76
- 6- or mark indicator → P.5-6
- 7- Information screen → P.5-5
- 8- Selector lever position display\* → P.6-30
- 9- Engine coolant temperature display  
→ P.5-7
- 10- Odometer → P.5-8
- 11- Fuel remaining display → P.5-7
- 12- Outside temperature display → P.5-8
- 13- Auto Stop & Go (AS&G) indicator display → P.6-23  
Auto Stop & Go (AS&G) OFF indicator display → P.6-27

Refer to “Multi information display - Type 1” on page 5-3.

#### Type 2

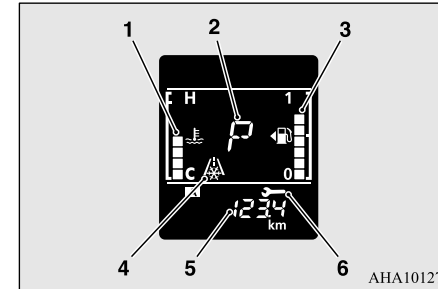

AHA101279

- 1- Engine coolant temperature display  
→ P.5-22
- 2- Selector lever position display\*  
→ P.6-30
- 3- Fuel remaining display → P.5-22
- 4- Frozen road warning\* → P.5-21
- 5- Information display → P.5-19
- 6- Service reminder → P.5-23

Refer to “Multi information display - Type 2” on page 5-18.

## *General information*

Fuel selection .....	2-2
Filling the fuel tank .....	2-2
Entering or leaving the vehicle* .....	2-4
Installation of accessories .....	2-4
Modification/alterations to the electrical or fuel systems .....	2-5
Genuine parts .....	2-5
Safety and disposal information for used engine oil .....	2-6
Event Data Recording .....	2-6

## Fuel selection

2

### Fuel selection

E00200105139

Recommended fuel	Cetane number (EN590) 51 or higher
------------------	---------------------------------------

#### CAUTION

- Your vehicles are designed to use only diesel fuel that meets the EN 590 standard. Use of any other type of diesel fuel would adversely affect the engine's performance and durability.
- If you continuously use fuel that contains more than 7 % bio-diesel, the impurities in the bio-diesel could precipitate. If this occurs, the properties of the fuel in the fuel tank will change, which could adversely affect the engine, fuel filter, and other components, leading to engine problems. If the engine is not operating properly, switch to fuel that contains 7 % or less bio-diesel as soon as possible and have the vehicle checked at an authorised MITSUBISHI MOTORS dealer.

#### NOTE

- Poor-quality diesel fuel can cause deposits to form in the injector, resulting in black smoke and rough idling. If these problems occur, you are advised to add a cleaning additive to the diesel fuel when you refuel the vehicle. The additive will break up and remove the deposits, thereby returning the engine to a normal condition. Be sure to use a MITSUBISHI MOTORS GENUINE DIESEL FUEL SYSTEM CLEANER. Using an unsuitable additive could make the engine malfunction. For detailed, please contact the nearest authorised MITSUBISHI MOTORS dealer.

### Filling the fuel tank

E00200204755

#### WARNING

- When handling fuel, comply with the safety regulations displayed by garages and filling stations.
- Fuel is highly flammable and explosive. You could be burned or seriously injured when handling it. When refueling your vehicle, always turn the engine off and keep away from flames, sparks, and smoking materials. Always handle fuel in well-ventilated outdoor areas.

#### WARNING

- Before removing the fuel cap, be sure to get rid of your body's static electricity by touching a metal part of the vehicle or fuel pump. Any static electricity on your body could create a spark that ignites fuel vapor.
- Perform the whole refueling process (opening the fuel tank filler door, removing the fuel cap, etc.) by yourself. Do not let any other person come near the fuel tank filler. If you allowed a person to help you and that person was carrying static electricity, fuel vapor could be ignited.
- Do not move away from the fuel tank filler until refueling is finished. If you moved away and did something else (for example, sitting on a seat) part-way through the refueling process, you could pick up a fresh charge of static electricity.
- Be careful not to inhale fuel vapor. Fuel contains toxic substances.
- Keep the doors and windows closed while refueling the vehicle. If they were open, fuel vapor could get into the cabin.
- If the fuel cap must be replaced, use only a MITSUBISHI MOTORS genuine part.

### Fuel tank capacity

Short wheel base vehicles: 68 litres  
Except for short wheel base vehicles: 75 litres

## Refueling

1. Before filling with fuel, stop the engine.
2. The fuel tank filler is located on the rear left side of your vehicle. (Only vehicles for Type 1, 2)  
Open the fuel tank filler door with the release lever located below the instrument panel.

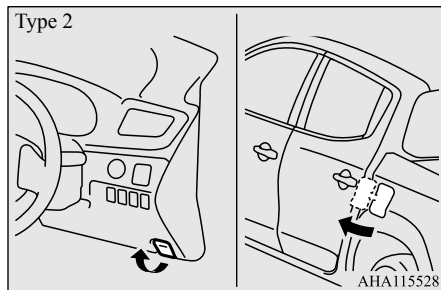
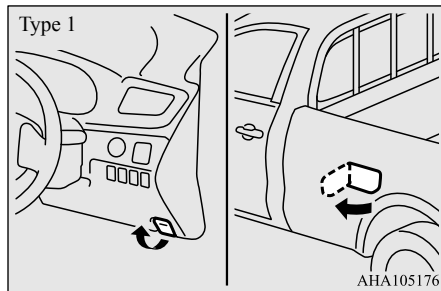

3. [Vehicles for Type 1, 2]  
Open the fuel tank filler tube by slowly turning the fuel cap anticlockwise.

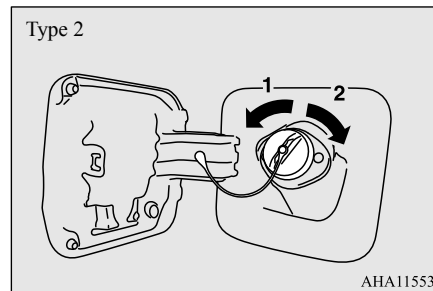
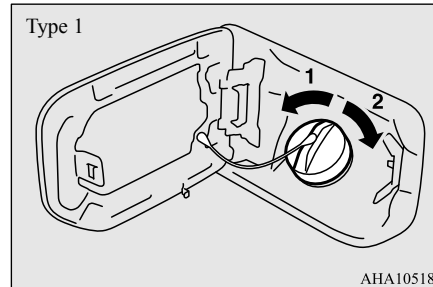

- 1- Remove
- 2- Close

- [Vehicles for Type 3]  
Open the cover (1). Insert the key in the fuel cap (2) and unlock it.  
Turn the fuel cap and remove it.

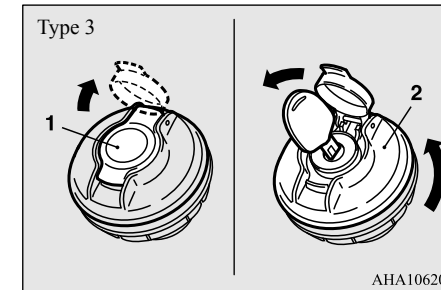

### CAUTION

- Since the fuel system may be under pressure, remove the fuel cap slowly. This relieves any pressure or vacuum that might have built up in the fuel tank. If you hear a hissing sound, wait until it stops before removing the fuel cap. Otherwise, fuel may spray out, injuring you or others.

2

## Entering or leaving the vehicle\*

2

### NOTE

- [Vehicles for Type 1]  
While filling with fuel, hang the fuel cap on the hook (A) located on the inside of the fuel tank filler door.

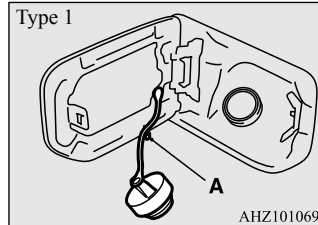

- [Vehicles for Type 2]  
While filling with fuel, store the fuel cap in the cap holder located on the inside of the fuel tank filler door.

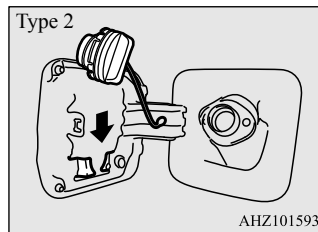

4. Insert the gun in the tank port as far as it goes.

### CAUTION

- Do not tilt the gun.

5. When the gun stops automatically, do not fill with fuel any more.

6. [Vehicles for Type 1, 2]  
To close, turn the fuel cap slowly clockwise until you hear clicking sounds, then gently push the fuel tank filler door closed.

[Vehicles for Type 3]  
To close, turn the fuel cap slowly clockwise until you hear clicking sounds, then turn the key clockwise to lock the fuel cap.

### Entering or leaving the vehicle\*

E0020580048

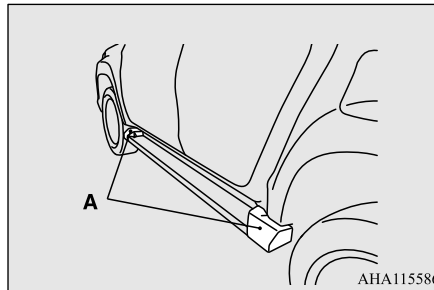

### CAUTION

- To avoid slipping and damaging the painted surface, do not step on the cover of side step (A).

### Installation of accessories

E00200302648

Before fitting any accessories, please consult your authorised MITSUBISHI MOTORS dealer.

### CAUTION

- Your vehicle is equipped with a diagnosis connector for checking and servicing the electronic control system.  
Do not connect a device other than a diagnosis tool for inspections and service to this connector. Otherwise, the battery could be discharged, the electronic devices of the vehicle could malfunction, or other unexpected problems could result.  
In addition, malfunctions caused by connecting a device other than a diagnosis tool may not be covered under warranty.

- The installation of accessories, optional parts, etc., should only be carried out within the limits prescribed by law in your country, and in accordance with the guidelines and warnings contained within the documents accompanying this vehicle.

Only MITSUBISHI MOTORS approved accessories should be fitted to your vehicle.

- Improper installation of electrical parts could cause fire, please refer to the Modification/alteration to the electrical or fuel systems section within this owner's manual.
- Using a cellular phone or radio set inside the vehicle without an external antenna may cause electrical system interference, which could lead to unsafe vehicle operation.
- Tyres and wheels which do not meet specifications must not be used. Refer to the "Specifications" section for information regarding wheel and tyre sizes.
- Do not fail to read the accessories manuals prior to the installation of accessories, parts or other modifications to the vehicle!

### Important points!

Due to a large number of accessories and replacement parts of different manufactures available in the market, it is not possible, not only for MITSUBISHI MOTORS but also an authorised MITSUBISHI MOTORS dealer, to check whether the attachment or installa-

tion of such parts affects the overall safety of your vehicle.

Even when such parts are officially authorised, for example by a "general operators permit" (an appraisal for the part) or through the execution of the part in an officially approved manner of construction, or when a single operation permit following the attachment or installation of such parts, it cannot be deduced from that alone, that the driving safety of your vehicles has not been affected.

Consider also that there basically exists no liability on the part of the appraiser or the official. Maximum safety can only be ensured with parts recommended, sold and fitted or installed by an authorised MITSUBISHI MOTORS dealer (MITSUBISHI MOTORS GENUINE replacement parts and MITSUBISHI MOTORS accessories). The same also pertains to modifications of vehicles with respect to the production specifications. For safety reasons, do not attempt any modifications other than those that follow the recommendations of an authorised MITSUBISHI MOTORS dealer.

## Modification/alterations to the electrical or fuel systems

E00200401495

2

MITSUBISHI MOTORS has always manufactured safe, high quality vehicles. In order to maintain this safety and quality, it is important that any accessory that is to be fitted, or any modifications carried out which involve the electrical or fuel systems, should be carried out in accordance with MITSUBISHI MOTORS guidelines.

### CAUTION

- Please consult an authorised MITSUBISHI MOTORS dealer concerning any such fitment or modification. If the wires interfere with the vehicle body or improper installation methods are used (protective fuses not included, etc.), electronic devices may be adversely affected, resulting in a fire or other accident.

## Genuine parts

E00200501803

Don't play around with substitutes. MITSUBISHI MOTORS has gone to great lengths to bring you a superbly crafted vehicle offering the highest quality and dependability. Don't reduce that quality and dependability by using substitute parts.



## Safety and disposal information for used engine oil

2

Always use MITSUBISHI MOTORS GENUINE PARTS designed and manufactured to maintain your vehicle at top performance. The operation of vehicle components can be less efficient in case of using Non-Genuine Parts.

Failure to use Genuine Parts may invalidate any future warranty claim. MITSUBISHI MOTORS will not be liable for any malfunction of your vehicle that may have been caused by the use of substitute parts in place of MITSUBISHI MOTORS GENUINE PARTS.

At the MITSUBISHI MOTORS dealer you can also get appropriate advice and the assembling of Genuine Parts will be handled professionally.

MITSUBISHI MOTORS GENUINE PARTS are identified by this mark, and are available at all authorised MITSUBISHI MOTORS dealers.

**MITSUBISHI MOTORS  
GENUINE PARTS**

### Safety and disposal information for used engine oil

E00200601442

#### WARNING

- Prolonged and repeated contact may cause serious skin disorders, including dermatitis and cancer.
- Avoid contact with the skin as far as possible and wash thoroughly after any contact.
- Keep used engine oils out of reach of children.

### Event Data Recording

E00205900212

This vehicle is equipped with an event data recorder (EDR).

The main purpose of an EDR is to record, in certain crash or near crash-like situations, such as an airbag deployment or hitting a road obstacle, data that will assist in understanding how a vehicle's systems performed. The EDR is designed to record data related to vehicle dynamics and safety systems for a short period of time, typically 30 seconds or less.

The EDR in this vehicle is designed to record such data as:

- How various systems in your vehicle were operating;
- How far (if at all) the driver was depressing the accelerator and/or brake pedal; and,
- How fast the vehicle was travelling.

These data can help provide a better understanding of the circumstances in which crashes and injuries occur.

#### NOTE

- EDR data are recorded by your vehicle only if a non-trivial crash situation occurs; no data are recorded by the EDR under normal driving conditions and no personal data (e.g., name, gender, age, and crash location) are recorded. However, other parties, such as law enforcement, could combine the EDR data with the type of personally identifying data routinely acquired during a crash investigation.

To read data recorded by an EDR, special equipment is required, and access to the vehicle or the EDR is needed. In addition to the vehicle manufacturer, other parties, such as law enforcement, that have the special equipment, can read the information if they have access to the vehicle or the EDR.

## *Locking and unlocking*

Keys .....	3-2
Key number tag .....	3-2
Electronic immobilizer (Anti-theft starting system)* .....	3-3
Keyless entry system* .....	3-4
Keyless operation system* .....	3-8
Doors .....	3-16
Central door locks* .....	3-17
“Child-protection” rear doors (Double cab) .....	3-19
Rear gate .....	3-19
Electric window control .....	3-21

## Keys

### Keys

E00300104713

3

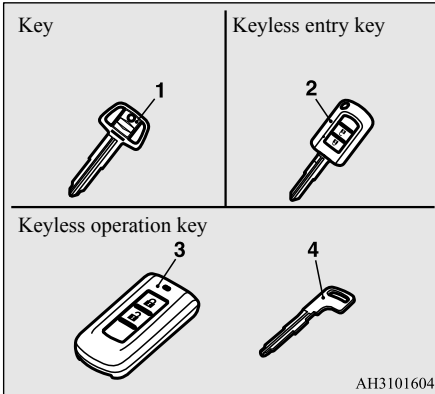

- 1- Master key (Plate)
- 2- Keyless entry key
- 3- Keyless operation key
- 4- Emergency key

### ⚠ WARNING

- When carrying a key on flights, do not press any switches on the key while on the plane. If a switch is pressed on the plane, the key emits electromagnetic waves, which could adversely affect the plane's flight operation. When carrying a key in a bag, be careful that no switches on the key can be easily pressed by mistake.

### 📖 NOTE

- On vehicles with electric immobilizer, the key (except for the emergency key) is a precision electronic part with a built-in signal transmitter. Please observe the following in order to prevent a malfunction.
  - Do not leave anywhere that is exposed to direct sunlight, for example on the dashboard.
  - Do not disassemble or modify.
  - Do not excessively bend the key or subject it to a strong impact.
  - Do not expose to water.
  - Keep away from magnetic key rings.
  - Keep away from audio systems, personal computers, TVs, and any other equipment that generates a magnetic field.
  - Keep away from devices that emit strong electromagnetic waves, such as cellular phones, wireless devices and high frequency equipment (including medical devices).
  - Do not wash with ultrasonic cleaners or similar equipment.
  - Do not leave the key where it may be exposed to high temperature or high humidity.
- On vehicles with electric immobilizer, the engine is designed so that it will not start if the ID code registered in the immobilizer computer and the key's ID code do not match. Refer to the section entitled "Electronic immobilizer" for details and key usage.

### 📖 NOTE

- If you lose one of them, contact an authorised MITSUBISHI MOTORS dealer as soon as possible to prevent theft.

### Key number tag

E00312701135

The key number is stamped on the tag as indicated in the illustration.

Make a record of the key number and store the key and key number tag in separate places, so that you can order a key from your authorised MITSUBISHI MOTORS dealer in the event the original keys are lost.

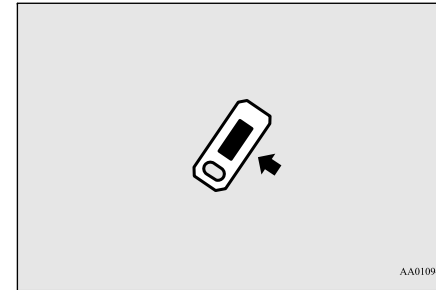

**Electronic immobilizer  
(Anti-theft starting system)\***

E00300203935

**⚠ CAUTION**

- Don't make any alterations or additions to the immobilizer system; alterations or additions could cause failure of the immobilizer.

The electronic immobilizer is designed to reduce significantly the possibility of vehicle theft. The purpose of the system is to immobilize the vehicle if an invalid start is attempted. A valid start attempt can only be achieved, using a key "registered" to the immobilizer system.

**📖 NOTE**

- [Vehicles without keyless operation system]  
In the following cases, the vehicle may not be able to receive the registered ID code from the registered key and engine may not start.

**📖 NOTE**

- When the key contacts a key ring or other metallic or magnetic object



- When the key grip contacts metal of another key

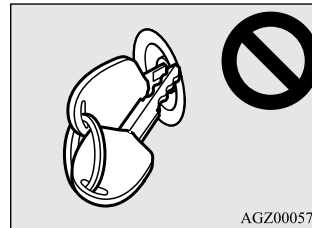

**📖 NOTE**

- When the key contacts or is close to other immobilizing keys (including keys of other vehicles)

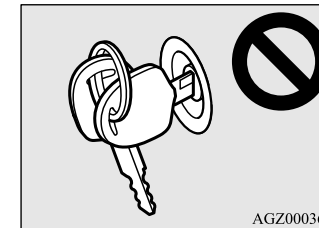

In cases like these, remove the object or additional key from the vehicle key. Then try again to start the engine. If the engine does not start, contact an authorised MITSUBISHI MOTORS dealer.

- [Vehicles with keyless operation system]  
If the engine does not start, contact an authorised MITSUBISHI MOTORS dealer.

**3**

## Keyless entry system\*

3

### NOTE

- If you lose one of the master keys, the keyless entry keys or the keyless operation keys, contact an authorised MITSUBISHI MOTORS dealer as soon as possible. Refer to “Keys” on page 3-2.

To obtain a key, take your vehicle and all remaining keys to an authorised MITSUBISHI MOTORS dealer.

If you need an extra spare key, take your vehicle and all the keys to an authorised MITSUBISHI MOTORS dealer. All the keys have to be re-registered in the immobilizer computer unit.

For further information, please contact an authorised MITSUBISHI MOTORS dealer.

- [Vehicles with keyless operation system]  
When the electronic immobilizer is abnormal, the warning lamp illuminates or warning display will appear. Put the operation mode in OFF and then start the engine again. If the warning is not cancelled, contact an authorised MITSUBISHI MOTORS dealer.

Warning lamp (mono-color liquid crystal display)



### NOTE

Warning display (color liquid crystal display)



## Keyless entry system\*

E00300305161

Press the key switch, and all doors will be locked or unlocked as desired.

It is also possible to operate the outside rear-view mirrors. (Vehicles equipped with the mirror retractor switch)

Keyless entry key      Keyless operation key

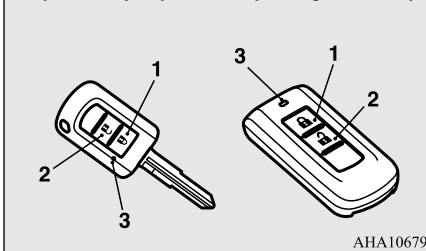

AHA106795

- 1- LOCK switch
- 2- UNLOCK switch
- 3- Indicator lamp

### To lock

Press the LOCK switch (1). All the doors will be locked. The turn-signal lamps will blink once. When they are locked with the room lamp switch in the “●” or the “DOOR” position, the room lamp also blink once.

### To unlock

Press the UNLOCK switch (2). All the doors will be unlocked. If the room lamp switch is in the “●” or the “DOOR” position at this time, the room lamp will come on for approximately 15 seconds and the turn-signal lamps will blink twice.

### NOTE

- For vehicles equipped with the mirror retractor switch, the outside rear-view mirrors automatically retract or extend when all the doors are locked or unlocked using the key switches of the keyless entry system. Refer to “Starting and driving: Outside rear-view mirrors” on page 6-9.
- If the UNLOCK switch (2) is pressed and no door is opened within approximately 30 seconds, relocking will automatically occur.
- It is possible to modify functions as follows:  
For further information, please contact an authorised MITSUBISHI MOTORS dealer.

 **NOTE**

- The time from pressing of the UNLOCK switch (2) to the moment of automatic locking can be changed.
- Activating the operation confirmation function (blinking of the turn-signal lamps) only during locking, or only during unlocking.
- The confirmation function (this indicates locking or unlocking of the doors with the blink of the turn-signal lamps) can be deactivated.
- The number of times the turn-signal lamps are blinked by the confirmation function can be changed.
- On vehicles with keyless operation system, the buzzer sound can be activated when a keyless operation is done.
- The keyless entry system does not operate in the following conditions:
  - The key is left in the ignition switch. (except for vehicles with keyless operation system)
  - The operation mode is not in OFF. (vehicles with keyless operation system)
  - The door is open.
- The key switch will operate within approximately 4 m from the vehicle. However, the operating range of the key switch may change if the vehicle is located near a TV transmitting tower, power station, or radio broadcasting station.
- If either of the following problems occurs, the battery may be exhausted.

 **NOTE**

- The key switch is operated at the correct distance from the vehicle, but the doors are not locked/unlocked in response.
- The indicator lamp (3) is dim or does not come on.

For further information, please contact an authorised MITSUBISHI MOTORS dealer. If you replace the battery yourself, refer to "Procedure for replacing the key battery" on page 3-6.

- If your key is lost or damaged, please contact an authorised MITSUBISHI MOTORS dealer for a replacement key.
- If you wish to add key, please contact an authorised MITSUBISHI MOTORS dealer. The following numbers of the keys are available.
  - Keyless entry key: up to 4 keys
  - Keyless operation key: up to 4 keys

**Operation of the outside rear-view mirrors (Vehicles equipped with the mirror retractor switch)**

E00310801826

**3****To retract**

Locking the doors using the LOCK switch (1), the outside rear-view mirrors are retracted automatically.

**To extend**

Unlocking the doors using the UNLOCK switch (2), the outside rear-view mirrors are extended automatically.

 **NOTE**

- Functions can be modified as stated below. Please consult an authorised MITSUBISHI MOTORS dealer.

## Keyless entry system\*

3

### NOTE

- Automatically extend when the driver's door is closed, and then the following operation is performed.  
[Except for vehicles equipped with the keyless operation system]  
Turn the ignition switch to the "ON" position.  
[Vehicles equipped with the keyless operation system]  
Put the operation mode in ON.
- Automatically retract when the ignition switch is turned to the "LOCK" or "ACC" position or the operation mode is put in OFF or ACC, and the driver's door is then opened.
- Automatically extend when the vehicle speed reaches approximately 30 km/h.

### NOTE

- Deactivate the automatic extension function.  
  
The outside rear-view mirrors can be retracted or extended by the following operations, even if changing to the any of above.  
After pressing the "LOCK" switch to lock the doors, if the "LOCK" switch is pressed again twice in a row within approximately 30 seconds, the outside rear-view mirrors will retract.  
After pressing the "UNLOCK" switch to unlock the doors, if the "UNLOCK" switch is pressed again twice in a row within approximately 30 seconds, the outside rear-view mirrors will extend again.

### Procedure for replacing the key battery

E00309502194

Before replacing the battery, remove static electricity from your body by touching a metal grounded object.

### WARNING

- Do not swallow a coin type battery.

### WARNING

- This product contains coin type battery. If a coin type battery is swallowed, it can cause severe internal burns and can lead to death.  
There have been cases where a swallowed battery has caused severe internal burns in just 2 hours.
- Keep new and used batteries away from children.
- If the remote control switch case does not close securely, stop using the product and keep it away from children.
- If you think batteries might have been swallowed or placed inside any part of a person's body, seek immediate medical attention.
- To prevent that can result in an explosion or the leakage of flammable liquid or gas.
- Do not replace an incorrectly battery. Replace only with the same or equivalent type.
- Do not dispose of a battery into fire or incinerator, or mechanically crushing or cutting of a battery.
- Do not use, store in or bring into a battery where it may be exposed to extremely high temperature or extremely low air pressure.

**CAUTION**

- When the key case is opened, be careful to keep water, dust, etc. out. Also, do not touch the internal components.
- Dispose of used battery according to the regulations for the disposal of battery.

**NOTE**

- You may purchase a replacement battery at an electric appliance store.
- An authorised MITSUBISHI MOTORS dealer can replace the battery for you if you prefer.

3. With the MITSUBISHI mark facing you, insert the cloth-covered tip of a straight blade (or minus) screwdriver into the notch in the key case and use it to open the case.

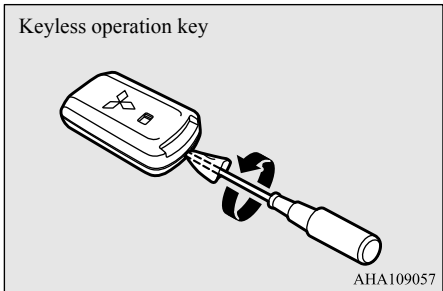
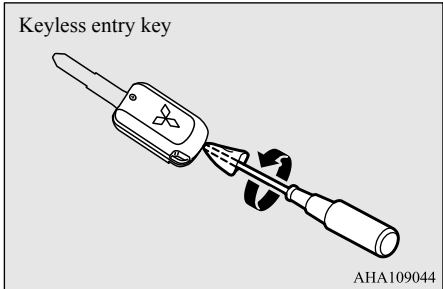

1. Remove the screw (A) from the key. (Keyless entry key only)

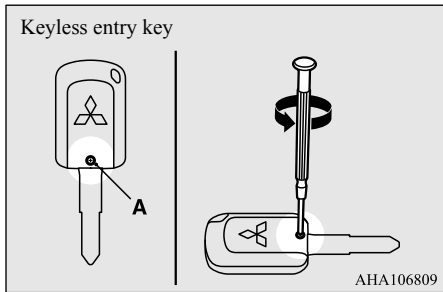

2. Remove the emergency key from the key. (Keyless operation key only)  
Refer to “Emergency key” on page 3-11.

**NOTE**

- Be sure to perform the procedure with the MITSUBISHI mark facing you. If the MITSUBISHI mark is not facing you when you open the key case, the switches may come out.

4. Remove the used battery.  
5. Install a new battery with the + side (B) up.

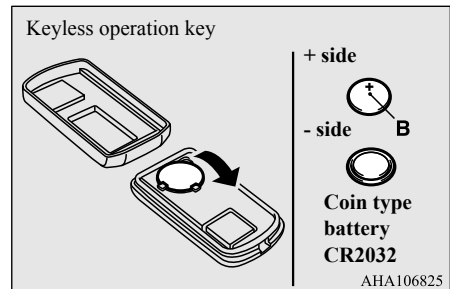
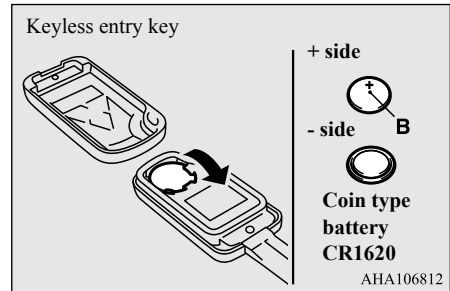



### Keyless operation system\*

6. Close the key case firmly.
7. Attach the screw (A) removed in step 1.  
(Keyless entry key only)
8. Install the emergency key removed in step 2.  
(Keyless operation key only)
9. Check the keyless entry system to see that it works.

3

### Keyless operation system\*

E00305602676

The keyless operation system allows you to lock and unlock the doors, start the engine and change the operation mode simply by carrying the keyless operation key with you. The switches on the keyless operation key can also be used as the key switch of keyless entry system.

Refer to “Starting and stopping the engine” on page 6-18.

Refer to “Keyless entry system” on page 3-4.

The driver should always carry the keyless operation key. This key is necessary for locking and unlocking the doors, starting the engine and otherwise operating the vehicle, so before locking and leaving the vehicle, be sure to check that you have the keyless operation key.

### ⚠ WARNING

- People with implantable cardiac pacemakers or implantable cardiovascular-defibrillators should not go near the exterior transmitters (A) or the interior transmitters (B). The radio waves used by the keyless operation system could adversely affect implantable cardiac pacemakers or implantable cardiovascular-defibrillators.

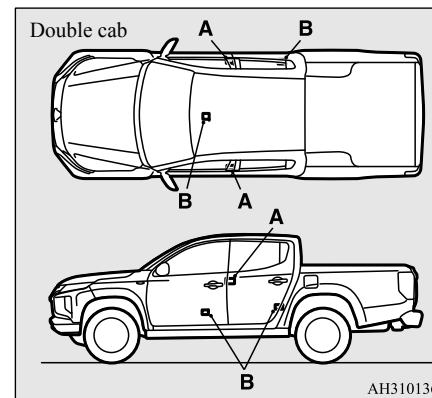
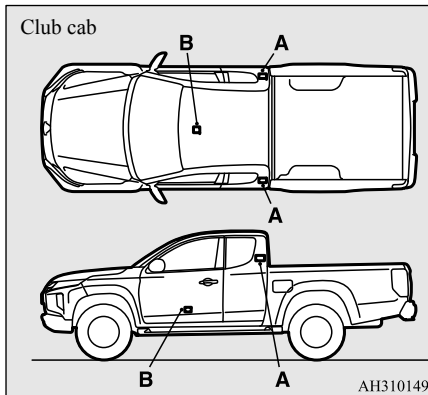

### ⚠ WARNING

- When using electro-medical devices other than implantable cardiac pacemakers or implantable cardiovascular-defibrillators, contact the electro-medical device manufacturer ahead of time to determine the adverse effects of radio waves on the devices. Electro-medical device operations could be affected by radio waves.

You can limit the possible operations of the keyless operation system in the following ways. (The keyless operation system can be used as a keyless entry system.) Please consult an authorised MITSUBISHI MOTORS dealer.

- You can limit operations to locking and unlocking the doors.
- You can limit operations to starting the engine.
- The keyless operation system can be disabled.

**NOTE**

- The keyless operation key uses an ultra-weak electromagnetic wave. In the following cases, the keyless operation system may not operate properly or may be unstable.
- When there is equipment nearby that emits strong radio waves, such as: a power station, a radio/TV broadcasting station or an airport.
- The keyless operation system is carried together with a communications device such as a cellular phone or radio set, or with an electronic device such as a personal computer.
- The keyless operation key is touching or covered by a metal object.
- A keyless entry system is being used nearby.
- When the keyless operation key battery is worn out.
- When the keyless operation key is set down in an area with strong radio waves or noise. In such cases, use the emergency key. Refer to “To lock/unlock without using the keyless operation function” on page 3-11.

**NOTE**

- Because the keyless operation key receives signals in order to communicate with the transmitters in the vehicle, the battery continually wears down regardless of keyless operation key use. The battery life is 1 to 2 years, depending on usage conditions. When the battery wears out, replace the battery according to the description in this manual or have it replaced an authorised MITSUBISHI MOTORS dealer. Refer to “Procedure for replacing the key battery” on page 3-6.
- Because the keyless operation key continually receives signals, strong radio wave reception could affect battery wear. Do not leave the key near a TV, personal computer, or other electronic device.

**Operating range of the keyless operation system**

E00305701609

If you are carrying the keyless operation key, enter the operating range of the keyless operation system, and press the driver’s or front passenger’s door lock/unlock switch, the ID code for your key is verified. You can lock and unlock the doors, start the engine and change the operation mode only if the ID codes of your keyless operation key and the vehicle match.

**NOTE**

- If the keyless operation key battery is wearing out or there are strong electromagnetic waves or noise present, the operating range may become smaller and operation may become unstable.

**3**

**Operating range for locking and unlocking the doors**

E00306201832

The operating range is approximately 70 cm from the driver’s or front passenger’s door lock/unlock switch.

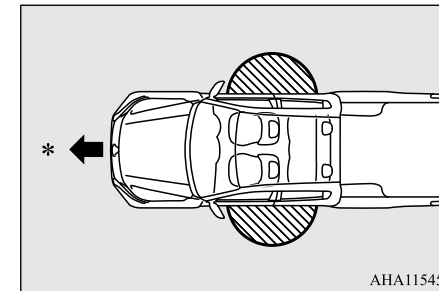

AHA115456

\*: Forward direction

: Operating range

## Keyless operation system\*

3

### NOTE

- Locking and unlocking operate only when you press a door switch that detects the keyless operation key.
- Operation may not be possible if you are too close to the front door, door window.
- Even if the keyless operation key is within 70 cm of the driver's or front passenger's door lock/unlock switch, if the key is near to the ground or high up, the system may not operate.
- If the keyless operation key is within the operating range, even someone not carrying the key can lock and unlock the doors by pressing the driver's or front passenger's door lock/unlock switch.

### Operating range for starting the engine and changing the operation mode

E00306301615

The operating range is the interior of the vehicle.

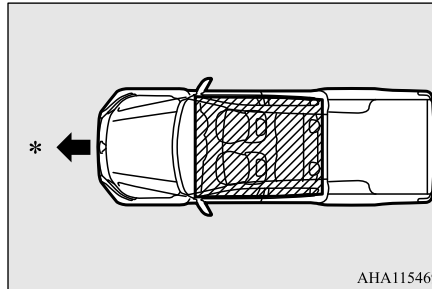

\*: Forward direction

: Operating range

### NOTE

- Even if it is within the operating range, if the keyless operation key is in a small item holder such as the glove box, on top of the instrument panel, door pocket or in the luggage compartment, it may be impossible to start the engine and change the operation mode.
- If a keyless operation key is too close to the door or door window, it may be possible to start the engine or change the operation mode even when the key is outside the vehicle.

### To operate using the keyless operation function

E00305802841

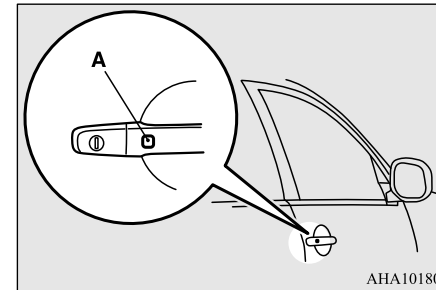

### Locking the doors

When you are carrying the keyless operation key, if you press the driver's or front passenger's door lock/unlock switch (A), within the operating range, the doors are locked.

The turn-signal lamps will blink once and the outer buzzer will sound once.

Also refer to "Locking and unlocking: Doors, Central door locks" on pages 3-16 and 3-17.

### Unlocking the doors

When you are carrying the keyless operation key, if you press the driver's or front passen-

ger's door lock/unlock switch (A), within the operating range, all the doors are unlocked.

If the room lamp switch is in the “●” or the “DOOR” position at this time, the room lamp will turn on for 15 seconds. The turn-signal lamps will blink twice and the outer buzzer will sound twice.

If the driver's or front passenger's door lock/unlock switch is pressed and any of the doors is not opened within approximately 30 seconds, relocking will automatically occur.

Refer to “Locking and unlocking: Doors, Central door locks” on pages 3-16 and 3-17.

#### NOTE

- For vehicles equipped with the mirror retractor switch, the outside rear-view mirrors automatically retract/extend when all the doors are locked/unlocked using the keyless operation function. Refer to “Starting and driving: Outside rear-view mirrors” on page 6-9.
- The keyless operation function does not operate under the following conditions:
  - The keyless operation key is inside the vehicle.
  - A door is open or ajar.
  - The operation mode is not in OFF.
- The time between unlocking and automatic locking can be adjusted. Please consult an authorised MITSUBISHI MOTORS dealer.

#### Operation confirmation when locking and unlocking

Operation can be confirmed as shown below. However, the room lamp will illuminate only if the room lamp switch is in the “●” or the “DOOR” position.

When locking: The turn-signal lamps blink once and the outer buzzer sounds once.

When unlock- ing: The room lamp illuminates for approximately 15 seconds, the turn-signal lamps blink twice, and the outer buzzer sounds twice.

#### NOTE

- Functions can be modified as stated below. For further information, please contact an authorised MITSUBISHI MOTORS dealer.
  - Activating the operation confirmation function (blinking of the turn-signal lamps) only during locking, or only during unlocking.
  - Disabling the operation confirmation function (blinking of the turn-signal lamps) and outer buzzer.
  - Changing the number of blinks for the operation confirmation function (blinking of the turn-signal lamps).

#### To lock/unlock without using the keyless operation function

E00306000165

#### Emergency key

E00307201611

The emergency key (A) can only be used to lock and unlock the door. To use the emergency key, unlock the lock knob (B) and remove it from the keyless operation key (C).

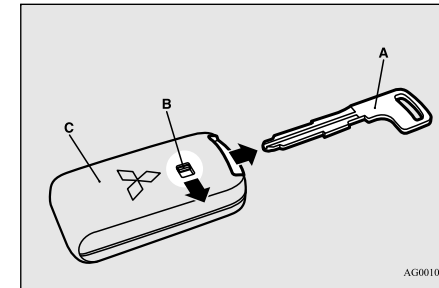

#### NOTE

- Only use the emergency key for emergencies. If the keyless operation key battery wears out, replace it as quickly as possible so that you can use the keyless operation key.
- The emergency key is built in the keyless operation key.
- After using the emergency key, always return it into the original position.

3

## Keyless operation system\*

### Locking and unlocking the door

3

Turning the emergency key in the forward direction locks the door, and turning it in the rear direction unlocks the door. Also refer to “Locking and unlocking: Doors” on page 3-16.

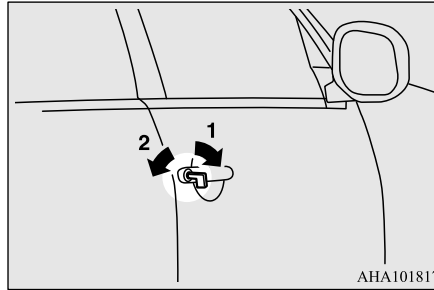

1- Lock

2- Unlock

## Warning activation



E00305902448

In order to prevent vehicle theft or the accidental operation of the keyless operation system, the buzzer and the display on the information screen in the multi information display are used to alert the driver.







If a warning is activated, always check the vehicle and the keyless operation key. The warning is also displayed if there is a fault in the keyless operation system.

TYPE 1:Color liquid crystal display type

TYPE 2:Mono-color liquid crystal display type

Item	TYPE 1		TYPE 2		Note (Solution)
	Display	Buzzer	Indicator	Buzzer	
Detection of failure		Inner buzzer sounds once	 Illuminates	No sounds	There is a fault in the keyless operation system.



3-12 Locking and unlocking







Item	TYPE 1		TYPE 2		Note (Solution)
	Display	Buzzer	Indicator	Buzzer	
Fall of battery voltage		Inner buzzer sounds once	 Blinks	No sounds	The battery starts to run out, the warning is activated. (The warning is not activated if the battery is completely dead.)
Key not detected		Inner buzzer sounds once	 Blinks	No sounds	When the engine switch is turned to the ACC or ON from OFF or when the engine is started, the warning is activated, if any of the following conditions is occurred. <ul style="list-style-type: none"> <li>• Carrying another keyless operation key with a different code, or the keyless operation key could be outside the operating range.</li> <li>• The battery of the keyless operation key is dead.</li> <li>• Communication is blocked by electric wave environment.</li> </ul>
Keyless operation key reminder		Inner buzzer sounds approximately 1 minute Outer buzzer sounds approximately 3 seconds intermittently	 Blinks	Inner buzzer sounds approximately 1 minute Outer buzzer sounds approximately 3 seconds	If the operation mode is in OFF and the driver's door is opened with the keyless operation key in the key slot, a warning is issued and the outer buzzer sounds for approximately 3 seconds and the inner buzzer sounds for approximately 1 minute to remind you to remove the key. If the key removed from key slot, the buzzer is stopped.

**3**

Keyless operation system\*

**3**

Item	TYPE 1		TYPE 2		Note (Solution)
	Display	Buzzer	Indicator	Buzzer	
Keyless operation key take-out monitoring system	 KEY NOT DETECTED	Inner buzzer sounds once Outer buzzer sounds intermittently	 Blinks	Inner buzzer sounds once Outer buzzer sounds intermittently	<ul style="list-style-type: none"> <li>• When the vehicle is parked with the operation mode in any mode other than OFF, if you close the door after opening any of the doors and taking the keyless operation key out of the vehicle, a warning is issued until the key is detected in the vehicle.</li> <li>• If you take the keyless operation key out of the vehicle through a window without opening a door, the keyless operation key take-out monitoring system does not operate.</li> <li>• It is possible to change the setting to make the keyless operation key take-out monitoring system operate if you take the keyless operation key out from the vehicle through a window without opening a door. For further information, please contact an authorised MITSUBISHI MOTORS dealer.</li> <li>• Even if you have the keyless operation key within the engine start operating range, if the keyless operation key and vehicle ID codes cannot be matched, for example due to the ambient environment or electromagnetic conditions, the warning may be activated.</li> </ul>

Item	TYPE 1		TYPE 2		Note (Solution)
	Display	Buzzer	Indicator	Buzzer	
Key lock-in prevention system		Inner buzzer sounds once Outer buzzer sounds approximately 3 seconds intermittently	 Blinks	Outer buzzer sounds approximately 3 seconds intermittently	<ul style="list-style-type: none"> <li>When the operation mode is in OFF, if you close all the doors with the keyless operation key left in the vehicle and you try to lock the doors by pressing the driver's or front passenger's door lock/unlock switch, a warning is issued and you cannot lock the doors.</li> <li>Make sure you have the keyless operation key with you before locking the doors. Even if you leave the keyless operation key inside the vehicle, it is possible that the doors will lock depending on the surrounding environment and wireless signal conditions.</li> </ul>
Door ajar prevention system		Inner buzzer sounds once Outer buzzer sounds approximately 3 seconds intermittently	 Blinks	Outer buzzer sounds approximately 3 seconds intermittently	When the operation mode in OFF, if you try to lock the doors by pressing the driver's or front passenger's door lock/unlock switch with one of the doors not completely closed, a warning is issued and you cannot lock the doors.
Operation mode OFF reminder system		Inner buzzer sounds once Outer buzzer sounds approximately 3 seconds intermittently	 Blinks	Outer buzzer sounds approximately 3 seconds intermittently	When the operation mode is in any mode other than OFF, if you try to lock the doors by pressing the driver's or front passenger's door lock/unlock switch, a warning is issued and you cannot lock the doors.

3



## Doors

### Doors

E00300403722

3

#### CAUTION

- Make sure the doors are closed: driving with doors not completely closed is dangerous.
- Never leave children in the vehicle unattended.
- Be careful not to lock the doors while the key is inside the vehicle.

#### NOTE

- To prevent the key from being locked inside the vehicle, neither the lock knob on the driver's door nor the key can be used to lock the driver's door when it is open.

#### To lock or unlock with the key

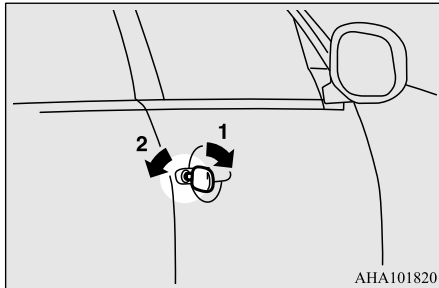

1- Lock

#### 2- Unlock

#### NOTE

- On vehicles with central door locks, when locking or unlocking with the key, all doors will be locked or unlocked. Refer to "Central door locks" on page 3-17.
- If the vehicle is equipped with the keyless operation system, the driver's door can be locked or unlocked with the emergency key. Refer to "Emergency key" on page 3-11.

#### To lock or unlock from inside the vehicle

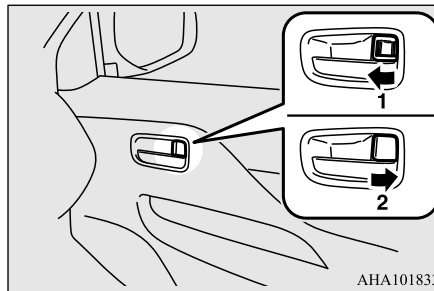

1- Lock  
2- Unlock

#### NOTE

- The driver's door can be opened without using the lock knob by pulling on the inside door handle. On vehicles with central door locks, all other doors are unlocked at the same time.

#### To lock without using the key

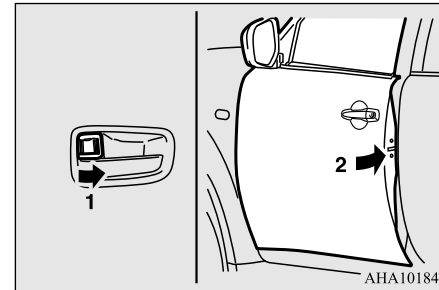

Set the inside lock knob (1) to the locked position, and close the door (2).

#### NOTE

- The driver's door cannot be locked using the inside lock knob while the driver's door is opened.

### To open or close the rear door (Club cab)

E0031380022

You can open or close the rear door while the front door is opened.

1. Open the front door wide.
2. Pull the door handle (A) of the rear door.

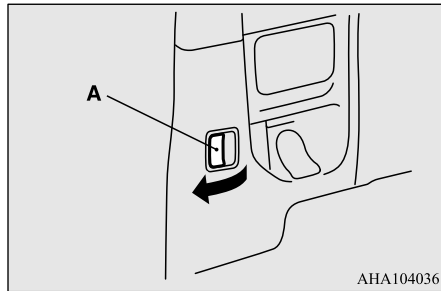

AHA104036

3. Open the rear door.
4. When closing these doors, close the front door after closing the rear door.

### WARNING

- When opening the rear door, confirm that the occupant of the front seat has taken off the seat belt before opening the rear door. If you open the rear door with the front seat belt being worn, the occupant of the front seat may be tightened with the locked seat belt and could result in serious injury.
- When closing the rear door, make sure not being trapped your hands or your fingers in the doors.
- Before driving, make sure that the rear door is securely closed. If a door is ajar, the door ajar warning lamp will illuminate. If a door is not completely closed, the rear door could open while driving and this could cause an accident such as occupants being thrown from the vehicle.

### CAUTION

- When opening or closing the rear door, please observe the followings. If you do not follow them, it could result in damage to your vehicle.
  - Do not open or close the rear door when the front door is not completely opened.
  - Do not open or close the rear door and the front door at the same time.
  - Do not close the rear door after closing the front door.

### Central door locks\*

E00300803322

### NOTE

- Repeated continuous operation between lock and unlock could activate the central door locking systems built-in protection circuit and prevent the system from operating. If this occurs, wait approximately 1 minute before operating the central door lock system.

3

All of the doors can be locked and unlocked as described hereafter.

### Driver's door with key

Using the key on the driver's door locks or unlocks.

Central door locks\*

**3**

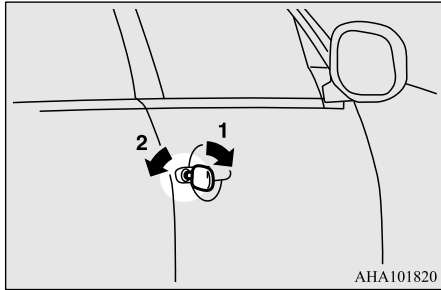

- 1- Lock
- 2- Unlock

AHA101820

**NOTE**

- If the vehicle is equipped with the keyless operation system, the driver's door can be locked or unlocked with the emergency key. Refer to "Emergency key" on page 3-11.

**Driver's door with inside lock knob**

Using the door lock knob on the driver's door locks or unlocks all doors.

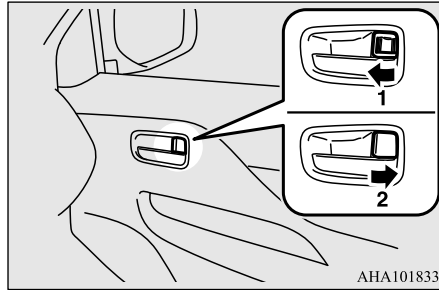

- 1- Lock
- 2- Unlock

AHA101833

**NOTE**

- Be careful not to lock the doors while the key is inside the vehicle when getting off the vehicle.

**Vehicle-speed sensitive automatic door lock (with impact-sensitive unlock mechanism)\***

All of the doors lock automatically when the vehicle speed exceeds approximately 15 km/h. In addition, all of the doors unlock when a strong impact that could be very dangerous to the occupants is sustained by the collision of the vehicle. This is prepared for

rescue activities when an unexpected accident occurs.

**WARNING**

- When the vehicle-speed sensitive automatic door lock/Impact-sensitive unlock mechanism may not operate in the following conditions, have the vehicle inspected at an authorised MITSUBISHI MOTORS dealer immediately.
  - The door does not lock automatically even when the vehicle speed exceeds approximately 15 km/h.
  - The door unlocks automatically while driving.
  - Even when the ignition switch or the operation mode is in ON, the SRS warning lamp does not come on or it remains on.
  - The SRS warning lamp comes on while driving.
  - The central door lock system is broken down.

**NOTE**

- Even if the vehicle suffers significant deformation from a collision etc., depending on the location and angle of the collision, as well as on the shape and condition of the other object in the collision, the doors may not unlock. The extent of deformation or damage to the vehicle does not necessarily correlate with unlock of the doors.

## “Child-protection” rear doors (Double cab)

### NOTE

- These functions are activated when the vehicle is shipped from the factory. If you wish to activate or deactivate these functions, please contact an authorised MITSUBISHI MOTORS dealer.

### Unlock using the ignition switch, the engine switch or the selector lever

It is possible to unlock all of the doors whenever as follows.

[Vehicles with M/T]

The ignition switch is turned to the “LOCK” position or the operation mode is put in OFF.

[Vehicles with A/T]

The selector lever placed the “P” (PARK) position while the ignition switch or the operation mode is in ON.

Or the ignition switch is turned to the “LOCK” position or the operation mode is put in OFF.

These functions are deactivated when the vehicle is shipped from the factory. If you wish to activate or deactivate these functions, please contact an authorised MITSUBISHI MOTORS dealer.

### “Child-protection” rear doors (Double cab)

E00300902140

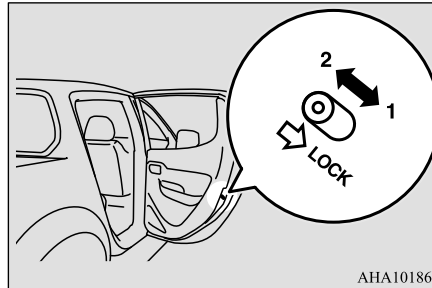

AHA101862

- 1- Lock
- 2- Unlock

Child protection helps prevent doors from being opened accidentally, especially when small children are in the rear seat.

A lever is provided on each rear door.

If the lever is set to the locked position, the rear door cannot be opened using the inside handle.

To open the rear door while the child protection is in use, pull the outside door handle.

If the lever is set to the “Unlock” position, the child protection mechanism does not function.

### CAUTION

- When driving with a child in the rear seat, please use the child protection to prevent accidental door opening which may cause an accident.

3

### Rear gate

E00303001174

### CAUTION

- Do not stand behind the exhaust pipe when loading and unloading luggage. Heat from the exhaust could lead to burns.
- Pay attention not to catch your fingers in the rear gate.
- Do not weight the rear gate.
- Before driving, make sure that the rear gate is securely closed. If the rear gate opens while driving the vehicle, objects stored in the cargo area could fall out onto the road.

### To open

Lift up the handle and lower the rear gate.

## Rear gate

3

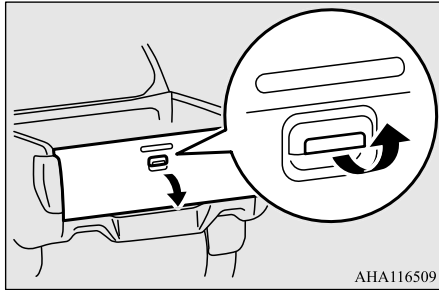

### To close

Raise the rear gate and close with enough force to latch the assembly securely into position.

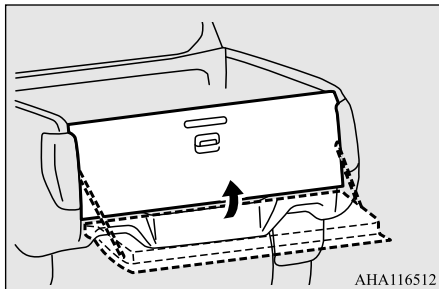

### To swing down

The rear gate can be swung down in two stages except some models. To lower it to the second stage, proceed as follows:

#### ⚠ CAUTION

- On vehicles with the rear bumper, never swing down the rear gate because the rear gate could be damaged.

1. Swing open the rear gate to the first position. Then, lift it up to the position shown in the illustration while holding the wire (A).

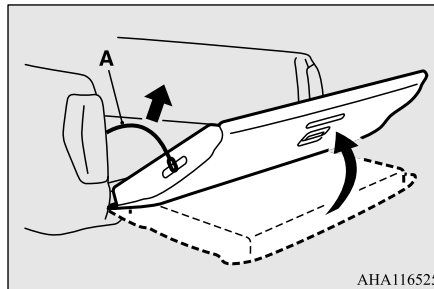

2. Remove the wire (A) on one side while aligning the hole in the wire with the hook (B).

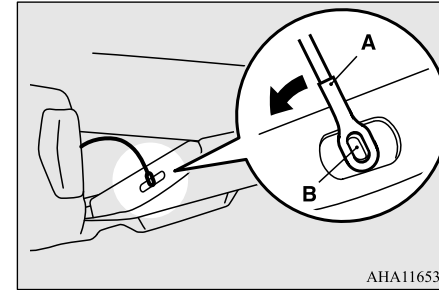

3. Remove the wire on the other side in the same manner, and have the rear gate swing down slowly.

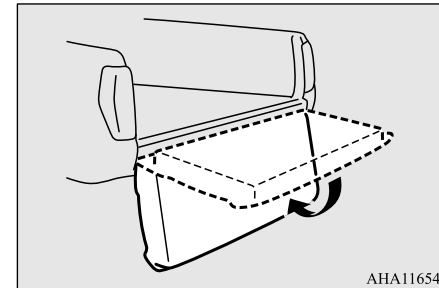

#### ⚠ CAUTION

- Never close the rear gate with the wire left unhooked.

## Electric window control

E00302201658

The electric windows can only be operated with the ignition switch or the operation mode in ON.

## Electric window control switch

E00302303275

Each door window opens or closes while the corresponding switch is operated.

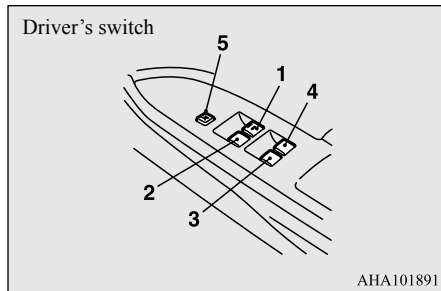

AHA101891

- 1- Driver's door window
- 2- Front passenger's door window
- 3- Rear left door window (Double cab)
- 4- Rear right door window (Double cab)
- 5- Lock switch

## WARNING

- Before operating the electric window control, make sure that nothing is capable of being trapped (head, hand, finger, etc.).
- Never leave the vehicle without removing the key.
- Never leave a child (or other person who might not be capable of safe operation of the electric window control) in the vehicle alone.

## Driver's switches

The driver's switches can be used to operate all door windows. A window can be opened or closed by operating the corresponding switch.

Press the switch down to open the window, and pull up the switch to close it.

[Type 1]

If the switch for the driver's door window is fully pressed down, the door window automatically opens completely.

[Type 2]

If the switch for the driver's window is fully pressed down/pulled up, the door window automatically opens/closes completely.

If you want to stop the window movement, operate the switch lightly in the reverse direction.

3

## Passenger's switches

The passenger's switches can be used to operate the corresponding passenger's door windows.

Press the switch down for opening the window, and pull up the switch for closing.

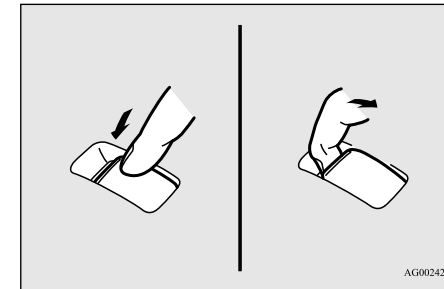

AG0024231

## Electric window control

3

### NOTE

- Repeated operation with the engine stopped will run down the battery. Operate the window switches only while the engine is running.
- The rear door windows only open halfway.

### Lock switch

E00303102316

When this switch is operated, the passenger's switches cannot be used to open or close the door windows and the driver's switch cannot open or close any door windows other than the driver's door window.

To unlock, press it once again.

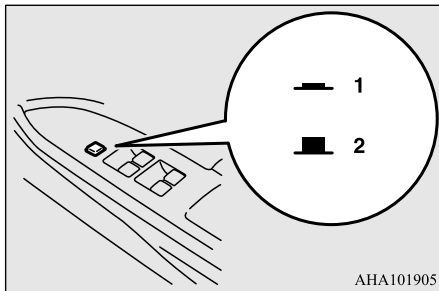

AHA101905

- 1- Lock
- 2- Unlock

### WARNING

- A child may tamper with the switch at the risk of its hands or head being trapped in the window. When driving with a child in the vehicle, please press the window lock switch to disable the passenger's switches.

### Timer function

E00302402149

The door windows can be opened or closed for 30 seconds after the engine is stopped. However, once the driver's door or the front passenger's door is opened, the windows cannot be operated.

### Safety mechanism (driver's window only of the vehicles with driver's switch Type 2)

E00302502179

When the door window is automatically closed by pulling up the switch fully, if a hand or head is trapped in the closing window, it will lower automatically.

Nonetheless, make sure that nobody puts their head or hand out of the window when closing the driver's door window.

The lowered window will become operational after a few seconds.

### WARNING

- If the battery terminals are disconnected or the fuse for electric window is replaced, the safety mechanism will be cancelled. If a hand or head got trapped, a serious injury could result.

### CAUTION

- The safety mechanism is cancelled just before the window is fully closed. This allows the window to close completely. Therefore be especially careful that no fingers are trapped in the window.
- The safety mechanism is deactivated while the switch is pulled up. Therefore be especially careful that fingers are not trapped in the door window opening.

### NOTE

- The safety mechanism can be activated if the driving conditions or other circumstances cause the driver's door window to be subjected to a physical shock similar to that caused by a trapped hand or head.

 **NOTE**

- If the safety mechanism is activated five or more times in a row, the safety mechanism will be cancelled and the door window will not close correctly.

In such a case, the following procedure should be implemented to rectify this situation. If the window is open, repeatedly raise the driver's door window switch until that window has been fully closed. Following this, release the switch, raise the switch once again and hold it in this condition for at least 1 second, then release it. You should now be able to operate in the normal fashion.

- If the battery terminals are disconnected or the fuse for electric window is replaced, the safety mechanism will be cancelled and the door window will not automatically open/close completely.

If the window is open, repeatedly raise the driver's door window switch until the window has been fully closed. Following this, release the switch, raise the switch once again and hold it in this condition for at least 1 second, then release it. You should now be able to operate the driver's door window in the normal fashion.





## *Seat and seat belts*

Seat adjustment .....	4-2
Front seats .....	4-2
Rear seat* .....	4-3
Head restraints .....	4-4
Seat belts .....	4-6
Pregnant women restraint .....	4-9
Seat belt pre-tensioner system and force limiter system* .....	4-9
Child restraint .....	4-10
Seat belt inspection .....	4-16
Supplemental restraint system (SRS)-airbag* .....	4-16

## Seat adjustment

### Seat adjustment

E00400302060

Adjust the driver's seat so that you are comfortable and that you can reach the pedals, steering wheel, switches etc. while retaining a clear field of vision.

4

#### **! WARNING**

- Do not attempt to adjust the seat while driving. This can cause loss of vehicle control and result in an accident. After adjustments are made, ensure the seating is locked in position by attempting to move the seat forward and rearward without using the adjusting mechanism.
- It is extremely dangerous to ride in the cargo area of a vehicle. Also, the cargo area and rear seats should never be used as a play area by children. In a collision, people or children riding unrestrained in these areas are more likely to be seriously injured or killed.
- Do not allow people or children to ride in any area of your vehicle that is not equipped with seats and seat belts, and make sure that everyone travelling in your vehicle is in a seat and wearing a seat belt, or in the case of a child is strapped in a child restraint.

#### **! WARNING**

- To minimize the risk of personal injury in the event of a collision or sudden braking, the seatbacks should always be in the almost upright position while the vehicle is in motion. The protection provided by the seat belts may be reduced significantly when the seatback is reclined. There is greater risk that the passenger will slide under the seat belt, resulting in serious injury, when the seatback is reclined.
- Do not place objects under the seats. This could prevent the seat from locking securely, and it could lead to an accident. It may also cause damage to the seat or other parts.

#### **! CAUTION**

- Make sure the seat is adjusted by an adult or with adult supervision for correct and safe operation.
- Do not place a cushion or the like between your back and the seatback while driving. The effectiveness of the head restraints will be reduced in the event of an accident.
- The reclining mechanism of the front manual seat's seatback is spring loaded, causing it to fold the seatback forward when the lock lever is operated. When using the lever, sit close to the seatback or hold it with your hand to control its return motion.
- When sliding the seats, be careful not to catch your hand or foot.

#### **! CAUTION**

- When sliding or reclining the seat rearward, pay careful attention to the rear seat passengers. (Double cab)

### Front seats

E00400401325

#### Manual type\*

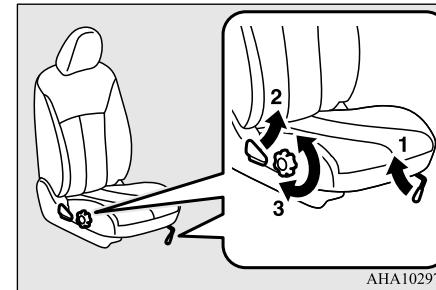

##### 1- To adjust forward or backward

Lift the handle and adjust the seat to the desired position, and release the handle.

##### 2- To recline the seatback

Pull the lever up and then lean backward to the desired position, and release the lever.

- 3- To adjust seat cushion height (driver's side only)\*  
Turn the dial and adjust the seat cushion height to the desired position.

### Power type\*

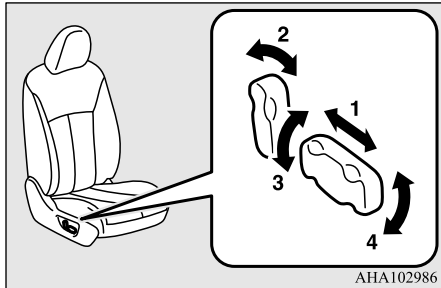

- 1- To adjust forward or backward  
Operate the switch as indicated by the arrows and adjust the seat to the desired position.
- 2- To recline the seatback  
Operate the switch as indicated by the arrows and adjust the seatback angle to the desired position.
- 3- To adjust seat height  
Operate the switch as indicated by the arrows and adjust the seat height to the desired position.  
If the entire switch is operated, then the entire seat moves.

- 4- To adjust seat cushion angle  
Operate the switch as indicated by the arrows and adjust the seat cushion angle to the desired position.

### NOTE

- To prevent the battery from running down, operate the switch with the engine running.

### Passenger's seat (Single cab)

E00415700026

[To access the onboard tool kit]  
Fold forward the seatback of the passenger's seat.  
Refer to "Tools, jack and jack handle" on page 8-6.  
Pull the band and fold the seatback forward.

[To recline the seatback]  
Pull the band and then lean backward to the desired position, and release the band.

### Rear seat\*

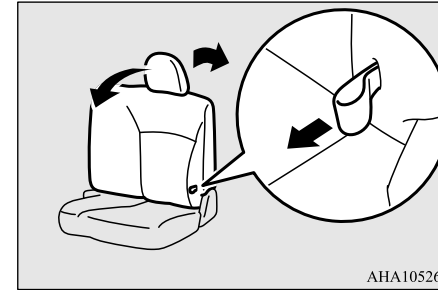

4

### Rear seat\*

E00401301493

On the vehicle equipped with the headrest at the middle seating position, when a person is sitting in the middle seating position of the rear seat, adjust the head restraint to height at which it lock in position. Refer to "Head restraints" on page 4-4.

### Folding the seatback forward

E00401601438

Pull up the band on the top of the seatback and fold it forward.

## Head restraints

4

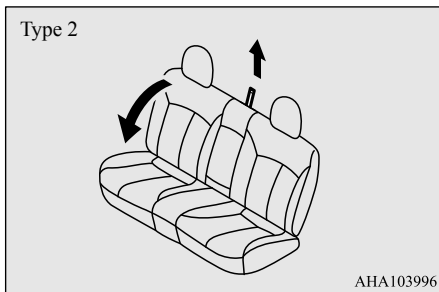
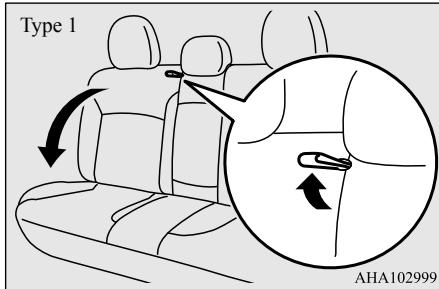

### To return

E0041560038

Raise the seatback until it is locked securely in place.  
Push and pull the seatback lightly to be sure it is secure.

### Armrest

E00401701774

To use the armrest, fold it down.  
To return to the original position, push it backward until it is flush with the seat.



### NOTE

- Do not climb or sit on the armrest. Doing so could damage the armrest.
- The top surface of the armrest contains a cup holder for rear seat occupants. Refer to “Cup holder” on page 7-76.

## Head restraints

E00403302931

### WARNING

- Driving without the head restraints in place can cause you and your passengers serious injury or death in an accident. To reduce the risk of injury in an accident, always make sure the head restraints are installed and properly positioned when the seat is occupied.
- Never place a cushion or similar device on the seatback. This can adversely affect head restraint performance by increasing the distance between your head and the restraint.

### To adjust height

#### Front seats

Adjust the head restraint height so that the centre of the head restraint is as close as possible to ear level to reduce the chances of injury in the event of collision. Any person too tall for the head restraint to reach their seated ear level, should adjust the restraint as high as possible.

To raise the head restraint, move it upward.  
To lower the restraint, move it downward while pushing the height adjusting knob (A)

in the direction of the arrow. After adjustment, push the head restraint downward and make sure that it is locked.

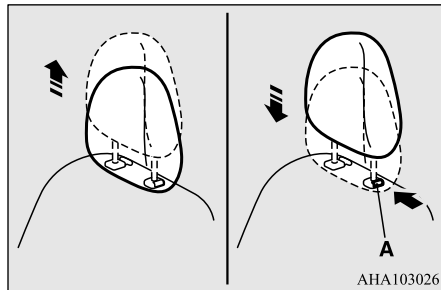

**Rear centre seat**

To reduce the risk of injury in an accident, pull up the head restraint to the locked position.

To raise the head restraint, move it upward. To lower the restraint, move it downward while pushing the height adjusting knob (A) in the direction of the arrow. After adjustment, push the head restraint downward and make sure that it is locked.

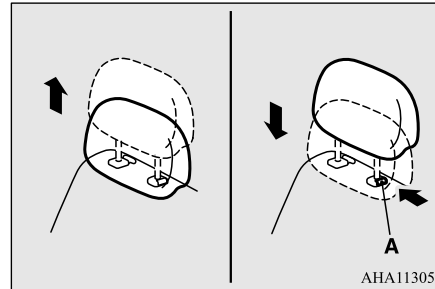

**WARNING**

- When a person sits in the middle seating position of the rear seat, pull up the head restraint to a height at which it locks in position. Be sure to make this adjustment before starting to drive. Serious injuries could otherwise be suffered in the result of an impact. (Double cab)

AHZ101418

**NOTE**

- The head restraint height of the outer seat in the rear seat cannot be adjusted.

**To remove**

Lift the head restraint with the height adjusting knob (A) pushed in.

**To install**

Confirm that the head restraint is facing the correct direction, and then insert it into the seatback while pressing the height adjusting knob (A) in the direction indicated by the arrow.

The head restraint stalk with the adjustment notches (B) must be installed in the hole with the adjusting knob (A). (except head restraints of the outer seat)

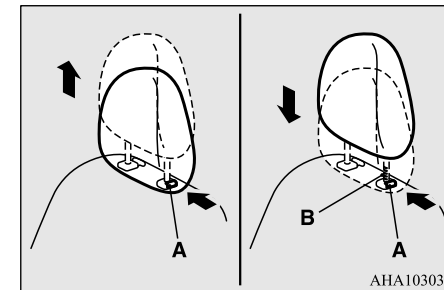

4

## Seat belts

4

### ⚠ CAUTION

- Confirm that the height adjusting knob (A) is correctly adjusted as shown in the illustration, and also lift the head restraints to ensure that they do not come out of the seat-back.

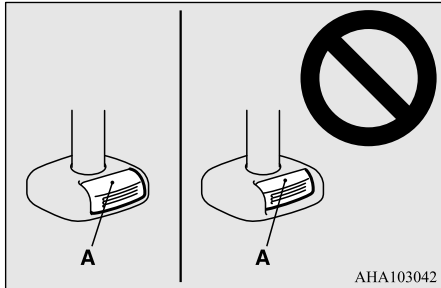

### ⚠ CAUTION

- If your vehicle is equipped with the rear seat head restraint, the shape and size of the head restraint differs according to the seat. Always use the correct head restraint provided for the seat and do not install the head restraint in the wrong direction.

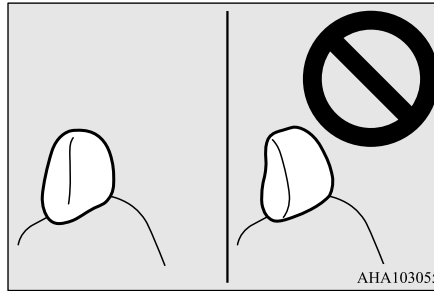

## Seat belts

E00404801936

To protect you and your passengers in the event of an accident, it is the most important that the seat belts be worn correctly while driving.

A seat belt for a seat equipped with an airbag has a pre-tensioner system. These belts are used the same way as a conventional seat belt.

Refer to “Seat belt pre-tensioner system and force limiter system” on page 4-9.

### ⚠ WARNING

- Seat belts should always be worn by every adult who drives or rides in this vehicle, and by all children who are large enough to wear seat belts properly. Other children should always use proper child restraint systems.
- Always place the shoulder belt over your shoulder and across your chest. Never put it behind you or under your arm.
- One seat belt should be used by only one person. Doing otherwise can be dangerous.
- The seat belt will provide its wearer with maximum protection if the recliner seat-back is placed in fully upright position. When the seatback is reclined, there is greater risk that the passenger will slide under the belt, especially in a forward impact accident, and may be injured by the belt or by striking the instrument panel or seatbacks.
- Remove any twists when using the belt.
- No modifications or additions should be made by the user which will either prevent the seat belt adjusting devices from operating to remove slack, or prevent the seat belt assembly from being adjusted to remove slack.
- Never hold a child in your arms or on your lap when riding in this vehicle, even if you are wearing your seat belt. To do so risks severe or fatal injury to your child in a collision or sudden stop.

**⚠ WARNING**

- Always adjust the seat belt to a snug fit.
- Always wear the lap portion of the belt over your hips.

**3-point type seat belt (with emergency locking mechanism)**

E00404902921

This type of belt requires no length adjustment. Once worn, the belt adjusts itself to the movement of wearer, but in the event of a sudden or strong shock, the belt automatically locks to hold the wearer's body.

**📖 NOTE**

- You can check if the belt locks by pulling it forward quickly.

**To fasten**

1. Pull the seat belt out slowly while holding the latch plate.

**📖 NOTE**

- When the seat belts cannot be pulled out in a locked condition, pull the belts once forcefully and then return them. After that, pull the belts out slowly once again.

2. Insert the latch plate into the buckle until a "click" is heard.

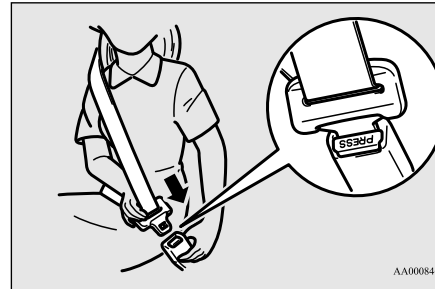

AA0008466

**⚠ WARNING**

- Never wear the lap portion of the belt across your abdomen. During accidents it can press sharply against abdomen and increase the risk of injury.
- The seat belts must not be twisted when worn.

3. Pull the belt slightly to adjust slackness as desired.

**To unfasten**

Hold the latch plate and push the button on the buckle.

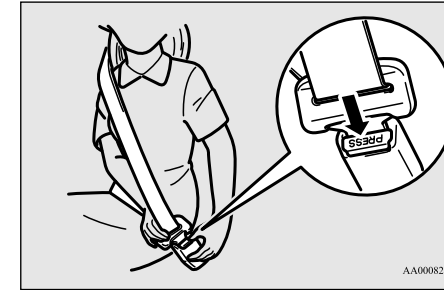

AA0008293

**📖 NOTE**

- As the belt retracts automatically, keep the latch plate held while retracting so that the belt stows slowly. Failure to do this could damage the vehicle.
- If the seat belt (A) or ring (B) becomes dirty, the belt may not retract smoothly. If the seat belt and ring are dirty, clean them with a mild soap or detergent solution.

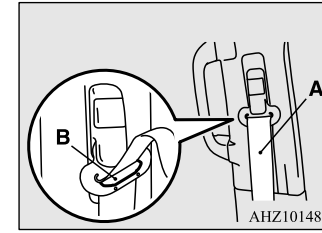

AHZ101489



## Seat belts

### Seat belt reminder\*

E00409802781

4

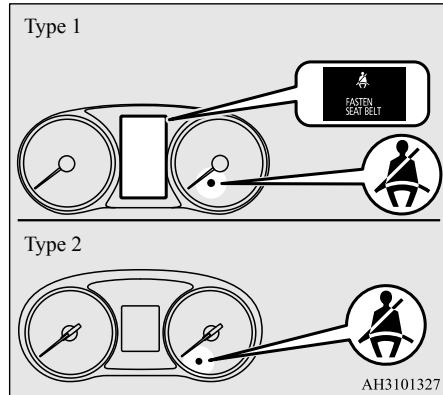

If the ignition switch is turned to the “ON” position or the operation mode is put in ON while a seat belt is not fastened, the warning lamp comes on and the tone sounds for approximately 6 seconds to remind the driver and/or the front passenger to fasten the seat belt.

If the vehicle is driven with the seat belt still unfastened, the warning lamp will blink and the tone will sound intermittently until the seat belt is fastened. At the same time, “FASTEN SEAT BELT” is displayed on the information screen in the multi information display.

### WARNING

- Do not install any accessory or sticker that makes the lamp difficult to see.

### NOTE

- If the seat belt subsequently remains unfastened, the warning lamp and the tone will issue further warnings each time the vehicle starts moving from a stop.
- For the front passenger seat, the warning function works only while a person is sitting on the seat.
- When luggage is placed on the front passenger seat, a sensor in the seat cushion may, depending on the weight and position of the luggage, cause the warning tone to sound and the warning lamp to come on.

### Adjustable seat belt anchor (front seats of Club cab and Double cab)

E00405001645

The seat belt anchor height can be adjusted. To move the anchor, pull the lock knob (A) and slide the anchor to the desired position. Release the lock knob to lock the anchor into position.

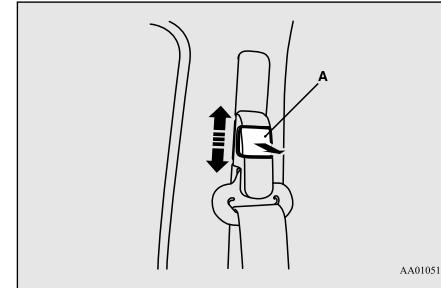

### WARNING

- When adjusting the seat belt anchor, set it at a position that is sufficiently high so that the belt will make full contact with your shoulder but will not touch your neck.

### Lap belts\*

E00405101226

The lap belts should be adjusted by holding the belt and latch plate at right angles to each other, and then pulling the belt as shown in the illustration to a snug fit around the occupant.

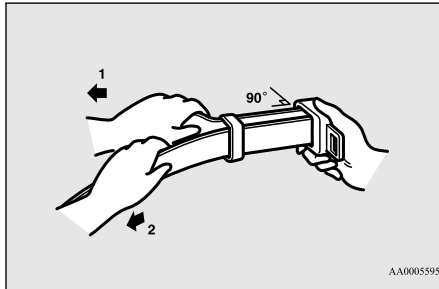

- 1- Tighten
- 2- Loosen

While holding the latch plate, insert the latch plate into the buckle until a “click” is heard.

### Pregnant women restraint

E00405600064

#### **WARNING**

- **Seat belts work for everyone, including pregnant women. Pregnant women should use the available seat belts. This will reduce the likelihood of injury to both the woman and the unborn child. The lap belt should be worn across the thighs and as snug against the hips as possible, but not across the waist. Consult your doctor if you have any additional questions or concerns.**

### Seat belt pre-tensioner system and force limiter system\*

E00405701411

The driver’s seat equipped with an airbag or the driver’s and front passenger’s seat equipped with airbags each have a pre-tensioner seat belt and force limiter system.

### Pre-tensioner system

E00405802288

When the ignition switch or the operation mode is under the following conditions, if there is a frontal impact or a side impact (vehicles equipped with SRS side airbags and SRS curtain airbags) severe enough to injure the driver and/or front passenger, the pre-tensioner system will retract their respective seat belts instantaneously, thus maximizing the seat belt’s effectiveness.

[Except for vehicles equipped with the keyless operation system]

The ignition switch is in the “ON” or “START” position.

[Vehicles equipped with the keyless operation system]

The operation mode is in ON.

#### **WARNING**

- **To obtain the best results from your pre-tensioner seat belt, make sure you have adjusted your seat correctly and wear your seat belt properly.**

**4**

#### **CAUTION**

- Installation of audio equipment or repairs in the vicinity of the pre-tensioner seat belts or floor console must be performed by an authorised MITSUBISHI MOTORS dealer. It is important to do so because the work could affect the pre-tensioner systems.
- If you need to scrap the vehicle, please consult an authorised MITSUBISHI MOTORS dealer. It is important to do so because unexpected activation of the pre-tensioner seat belts could cause injuries.

#### **NOTE**

- The pre-tensioner seat belts will be activated if the vehicle suffers a severe impact, even if the seat belts are not worn.
- The pre-tensioner seat belts are designed to work only once. After the pre-tensioner seat belts have been activated, they must be replaced by an authorised MITSUBISHI MOTORS dealer.

## Child restraint

### SRS warning

E00405900360

The same warning lamp/display is shared by the SRS airbags and the pre-tensioner seat belts.

**4**

Refer to “SRS warning lamp/display” on page 4-25 .

### Force limiter system

E00406001248

In the event of a collision, each force limiter system will effectively absorb the load applied to the seat belt so as to minimize the impact to the passenger.

### Child restraint

E00406403868

When transporting children in your vehicle, some type of child restraint system should always be used according to the size of the child. This is required by law in most countries.

The regulations concerning driving with children in the front seat may differ from country to country. You are advised to comply with the relevant regulations.

### ⚠ WARNING

- When possible, put children in the rear seat. Accident statistics indicate that children of all sizes and ages are safer when properly restrained in the rear seat rather than in the front seat. (Double cab)
- Holding a child in your arms is no substitute for a restraint system. Failure to use a proper restraint system can result in severe or fatal injury to your child.
- Each child restraint device or fixing is to be used only by one child.
- When attaching a child restraint system to the rear seat, prevent the front seatbacks from touching the child restraint system. Otherwise, the child could be seriously injured in the event of hard braking or a collision. (Double cab)

### Caution for installing the child restraint on vehicle with front passenger airbag\*

The label shown here is attached on vehicles with front passenger airbag.

Type 1

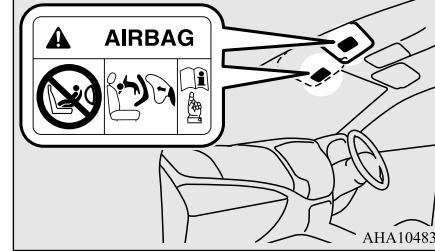

Type 2



### ⚠ WARNING

- **Extreme Hazard!**  
NEVER use a rearward facing child restraint on a seat protected by an ACTIVE AIRBAG in front of it, DEATH or SERIOUS INJURY to the CHILD can occur.

**⚠ WARNING**

- On vehicles with an airbag for the front passenger, a **REARWARD FACING CHILD RESTRAINT** must **NOT** be used in the front passenger seat as it places an infant too close to the passenger airbag. The force of an inflating airbag could kill or cause serious injuries to the child.



AJA102924

**⚠ WARNING**

- A **FORWARD FACING CHILD RESTRAINT** should not be used in the front passenger seat whenever possible; if used in the front passenger seat, adjust the seat to the most rearward position.



AHA100591

### Infants and small children

E00406602241

When transporting infants and small children in your vehicle, follow the instruction given below.

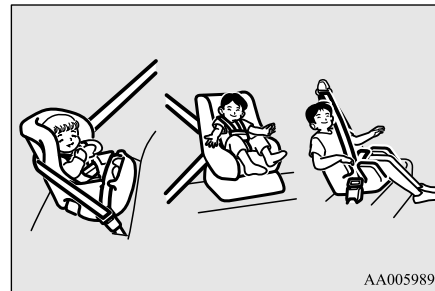

AA0059891

### Instruction:

- For small infants, an infant carrier should be used. For small children whose height when seated allows the shoulder belt to lie in contact with the face or the throat, a child seat should be used.
- The child restraint system should be appropriate for your child's weight and height and properly fit the vehicle. For a higher degree of safety: **THE CHILD RESTRAINT SYSTEM SHOULD BE INSTALLED IN THE REAR SEAT.** (Double cab)
- Before purchasing a child restraint system, try installing it in the seat to make sure there is a good fit. Because of the location of the seat belt buckles and the shape of the seat cushion, it may be difficult to securely install some manufacturer's child restraint systems. If the child restraint system can be pulled forward or to either side easily on the seat cushion after the seat belt has been tightened, choose another manufacturer's child restraint system.

## Child restraint

4

### **⚠ WARNING**

- When installing a child restraint system, refer to the instructions provided by the manufacturer of the restraint system. Failure to do so can result in severe or fatal injury to your child.
- After installation, push and pull the child restraint system back and forth, and side to side, to see that it is positively secured. If the child restraint system is not installed securely, it may cause injury to the child or other occupants in the case of accident or sudden stops.
- When the child restraint system is not in use, keep your child restraint system secured with the seat belt or remove it from the vehicle in order to prevent it from being thrown around inside the vehicle during an accident.

### **Older children**

E00406701333

Children who have outgrown the child restraint system should be seated in the seat and wear combination lap shoulder belt.

The lap portion of the belt should be snug and positioned low on the abdomen so that it is below the top of the hip-bone. Otherwise, the belt could intrude into the child's abdomen during an accident and cause injury.

4-12 Seat and seat belts

### **Child restraint anchorage points (Double cab)\***

E00406902198

When fitting a child restraint, always follow the manufacturer's instructions using the approved anchorage points shown and install the child restraint fitting package.

### **Anchorage locations**

Two child restraint anchorage points are built into the vehicle and are located on the vertical panel behind the rear seatback.

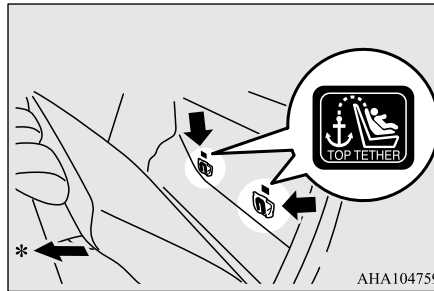

AHA104759

\*: Front of the vehicle

### **⚠ CAUTION**

- The anchorages are only applicable for child restraints fitted in the seat.

### **Tether anchor strap installation**

### **⚠ WARNING**

- Child restraint anchorages are designed to withstand only those loads imposed by correctly fitted child restraints. Under no circumstances are they to be used for adult seat belts, harnesses, or for attaching other items or equipment to the vehicle.

1. Remove the head restraint from the location in which you wish to install a child restraint.
2. Drop the child restraint's tether strap (A) down from the clearance between the rear seatback and back panel trim.

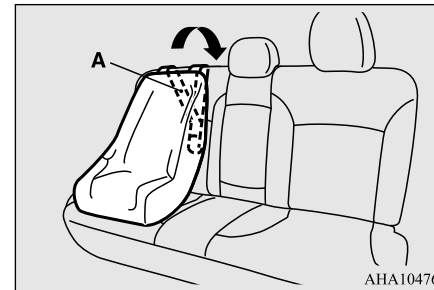

AHA104762

3. Tip the armrest forward. Open the fastener (B) that's located in the space where the armrest was stowed.

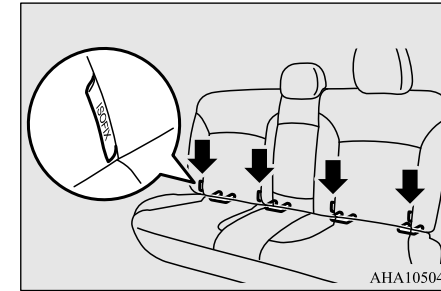
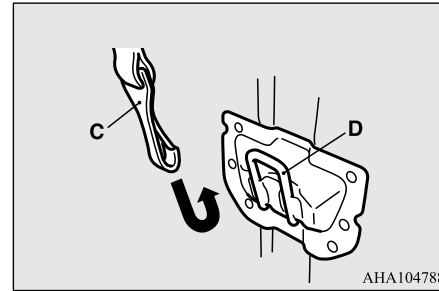
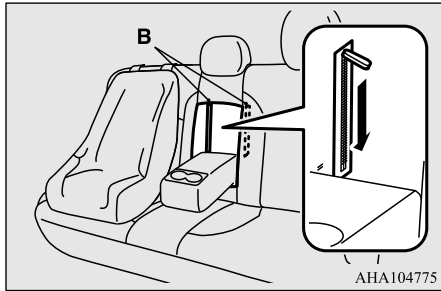

4

4. Open the inner cover.

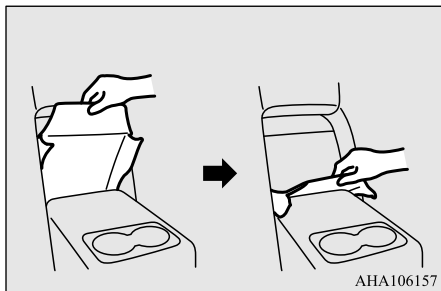

5. Put your hand in the opening of the fastener, attach the tether strap's hook (C) to the tether anchorage (D), and securely tighten the tether strap.

**Installing a child restraint system to the lower anchorage (ISOFIX child restraint mountings of Double cab)\***

E00408902219

Your vehicle's rear seat is fitted with lower anchorages for attaching a child restraint system with ISOFIX mountings.

**Child restraint system with ISOFIX mountings (Double cab)\***

E00409001656

The child restraint system is designed only for seats that incorporate lower anchorages. Retain the child restraint system using the lower anchorages.

It is not necessary to retain the child restraint system using the vehicle's seat belts.

## Child restraint

4

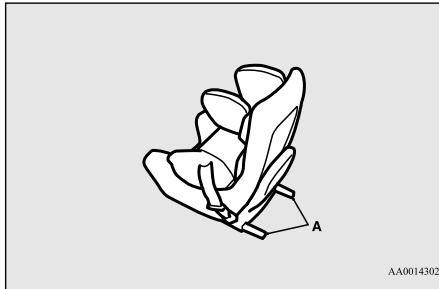

A: Child restraint system connectors

### To install

1. Remove any foreign material in or around the connectors and ensure the vehicle seat belt is in its normal storage position.
  2. Remove the head restraint from the location in which you wish to install a child restraint.
- Refer to “Head restraints” on page 4-4.

### CAUTION

- Do not remove the head restraint when installing a booster cushion.

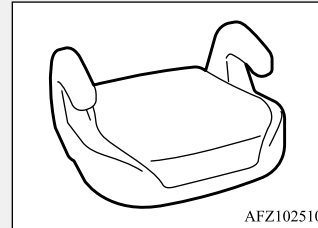

AFZ102510

3. Open the gap a little between the seat cushion (A) and the seatback (B) with your hand to locate the lower anchorage (C).
4. Push the child restraint system's connectors (D) into the lower anchorage (C) in accordance with the instructions provided by the child restraint system's manufacturer.

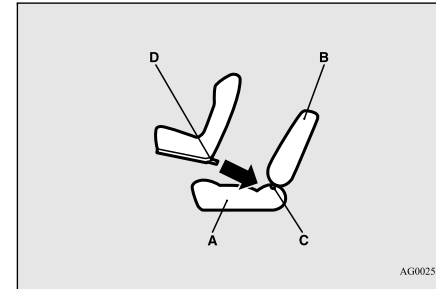

AG0025140

- A: Vehicle seat cushion  
B: Vehicle seatback  
C: Lower anchorage  
D: Connector

- If your child restraint system requires the use of a tether strap, fasten the tether strap in accordance with step 5.
5. Latch the top tether strap hook (E) of the child restraint system to the tether anchor bracket (F) and tighten the top tether strap so it is securely fastened.

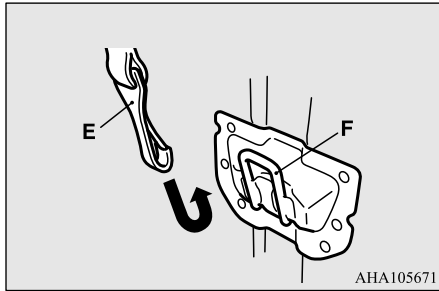

AHA105671

### Installing a child restraint system to a 3-point type seat belt (with emergency locking mechanism) or a lap belt

E00407102012

#### Installation:

1. Put a child restraint system on the seat in which you wish to install it, and remove the head restraint from the seat. Refer to "Head restraints" on page 4-4.

#### CAUTION

- Do not remove the head restraint when installing a booster cushion.

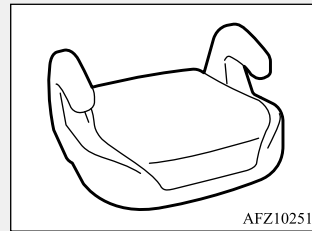

AFZ102510

2. Route the belt through the child restraint according to the child restraint system manufacturer's instructions, then insert the latch plate into the buckle.

3. Remove all slack of a lap belt by pulling the webbing through the belt's adjustment feature. 3-point type seat belt requires no length adjustment, remove all slack by using the locking clip (A).
4. Before putting the child in the restraint, push and pull the restraint in all directions to be sure it is secure. Do this before each use.

#### WARNING

- For some type of child restraint, the locking clip (A) should be used to help avoid personal injury during a collision or sudden manoeuvre. It must be fitted and used in accordance with the child restraint manufacturer's instructions. The locking clip must be removed when the child restraint is removed.

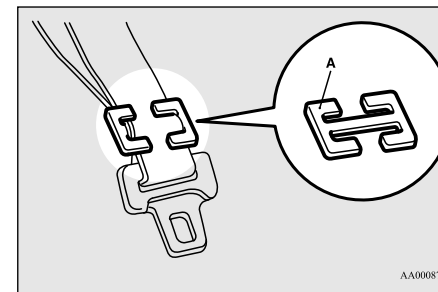

AA0008772

#### NOTE

- If it is difficult to latch the tether strap hook, turn the hook sideways.

6. Push and pull the child restraint system in all directions to be sure it is firmly secured.

#### To remove

Remove the child restraint system in accordance with the instructions provided by the child restraint system's manufacturer.



## Seat belt inspection

### Seat belt inspection

E00406301863

Check the belts for cuts, worn or frayed webbing and for cracked or deformed metallic parts. Replace the belt assembly if defective.

4

#### ⚠ WARNING

- All seat belt assemblies including retractors and attaching hardware should be inspected by an authorised MITSUBISHI MOTORS dealer after any collision. We recommend that seat belt assemblies in use during a collision be replaced unless the collision was minor and the belts show no damage and continue to operate properly.
- Do not attempt to repair or replace any part of the seat belt assemblies; this work should be done by an authorised MITSUBISHI MOTORS dealer. Failure to have an authorised MITSUBISHI MOTORS dealer perform the work could reduce the effectiveness of the belts and could result in serious injury in the event of a collision.
- Once the pre-tensioner has activated, it cannot be re-used. It must be replaced together with the retractor.

#### ⚠ WARNING

- Do not insert any foreign objects (pieces of plastic, paper clips, buttons, etc.) in the buckle or retractor mechanism. In addition, do not modify, remove, or install the seat belt. Otherwise, the seat belt may not be able to provide adequate protection in a collision or other situation.

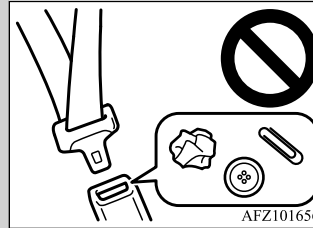

- A dirty belt should be cleaned with neutral detergent in warm water. After rinsing in water, let it dry in the shade. Do not attempt to bleach or re-dye the belts because this affects their characteristics.

### Supplemental restraint system (SRS)-airbag\*

E00407203414

The information for SRS airbags includes important information concerning the driver's and front passenger's airbags, the driver's knee airbag, the side airbags and the curtain airbags.

The SRS driver's and front passenger's airbags (if so equipped) are designed to supplement the primary protection of the driver and front passenger side seat belt systems by providing those occupants with protection against head and chest injuries in certain moderate-to-severe frontal collisions.

The SRS driver's knee airbag (if so equipped) is designed to supplement the primary protection of the driver's seat belt system. It can reduce the forward movement of the driver's lower legs and provide increased overall body protection in certain moderate-to-severe frontal collisions.

The SRS side airbags (if so equipped) are designed to supplement properly worn seat belts and provide the driver and front passenger with protection against chest injuries in certain moderate-to-severe side impact collisions.

The SRS curtain airbags (if so equipped) are designed to supplement properly worn seat belts and provide the driver and passenger with protection against head injuries in certain moderate-to-severe side impact collisions.

The SRS is NOT a substitute for the seat belts. To ensure the maximum protection during all types of collisions and accidents, all

Supplemental restraint system (SRS)-airbag\*

occupants, including the passengers as well as the driver, must wear their seat belts.

**How the supplemental restraint system works**

E00407303343

The SRS includes the following components:

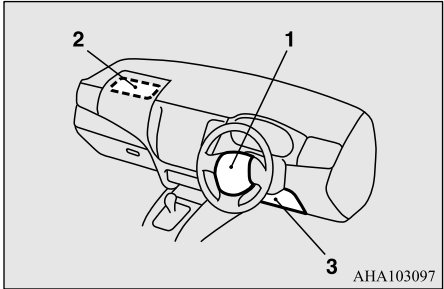

- 1- Airbag module (Driver)\*
- 2- Airbag module (Passenger)\*
- 3- Driver's knee airbag module\*

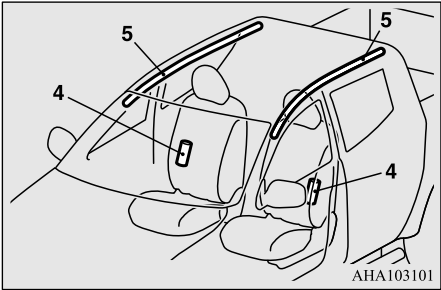

- 4- Side airbag modules\*
- 5- Curtain airbag modules\*

Only when the ignition switch or the operation mode is under the following conditions, the airbags will operate.  
 [Except for vehicles equipped with the keyless operation system]  
 The ignition switch is in the "ON" or "START" position.  
 [Vehicles equipped with the keyless operation system]  
 The operation mode is in ON.  
 The airbags deployment produces a sudden, loud noise, and releases some smoke and powder, but these conditions are not injurious, and do not indicate a fire in the vehicle. People with respiratory problems may feel some temporary irritation from chemicals used to produce the deployment; open the

windows after airbag deployment, if safe to do so.

The airbags deflate very rapidly after deployment, so there is little danger of obscured vision.

**CAUTION**

- Airbags inflate at an extremely rapid speed. In certain situations, contact with inflating airbags can result in abrasions, bruises, light cuts, and the like.

**WARNING**

- **IT IS VERY IMPORTANT TO BE PROPERLY SEATED.**  
 A driver or front passenger too close to the steering wheel or instrument panel during airbag deployment can be killed or seriously injured.  
 Airbags inflate very fast, and with great force.  
 If the driver and front passenger are not properly seated and restrained, the airbags may not protect you properly, and could cause serious or fatal injuries when they inflate.
- Do not sit on the edge of the seat, or sit with your lower legs too close to the instrument panel, or lean head or chest close to the steering wheel or instrument panel. Do not put feet or legs on or against the instrument panel.

Supplemental restraint system (SRS)-airbag\*

4

**⚠ WARNING**

- Place all infants and small children in the rear seat and properly restrained using an appropriate child restraint system. The rear seat is the safest for infants and children. (Double cab)

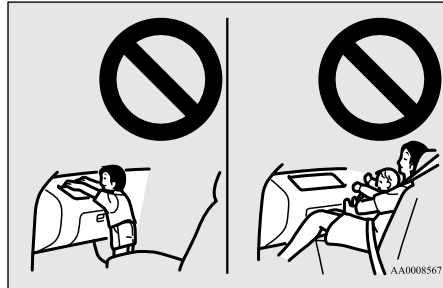
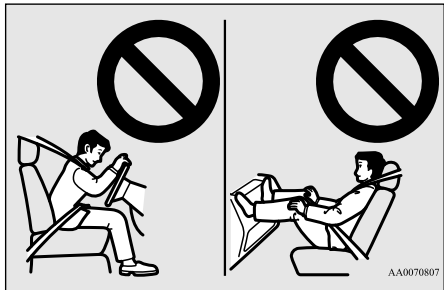

**⚠ WARNING**

- Older children should be seated, properly wearing the seat belt, with an appropriate booster seat if needed.

**Caution for installing the child restraint on vehicle with front passenger's airbag\***

E00408802494

The label shown here is attached on vehicles with front passenger's airbag.

**⚠ WARNING**

- Infants and small children should never be unrestrained, stand up against the instrument panel or held in your arms or on your lap. They could be seriously injured or killed in a collision, including when the airbag inflates. They should be properly seated in an appropriate child restraint system. See the "Child restraint" section of this owner's manual.

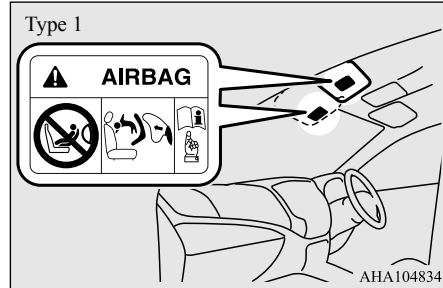

AHA104834

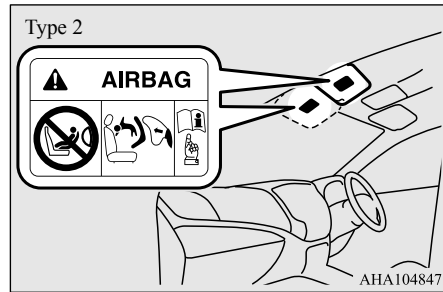

AHA104847

**⚠ WARNING**

- **Extreme Hazard!**  
NEVER use a rearward facing child restraint on a seat protected by an ACTIVE AIRBAG in front of it, DEATH or SERIOUS INJURY to the CHILD can occur.

**Driver's and front passenger's airbag system\***

E00407401874

The driver's airbag is located under the padded cover in the middle of the steering wheel. The front passenger's airbag is contained in the instrument panel above the glove box. The driver's airbag and the front passenger's airbag are designed to inflate at the same time even if the passenger seat is not occupied.

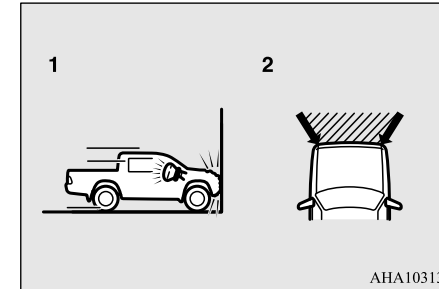
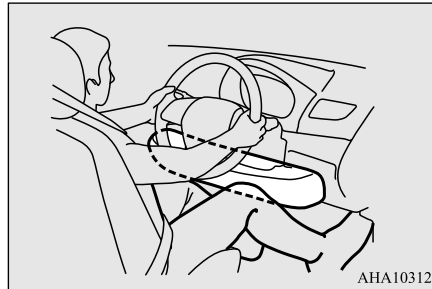

**4**

- 1- Head-on collision with a solid wall at speed of approximately 25 km/h or higher
- 2- Moderate to severe frontal impact within the shaded area between the arrows

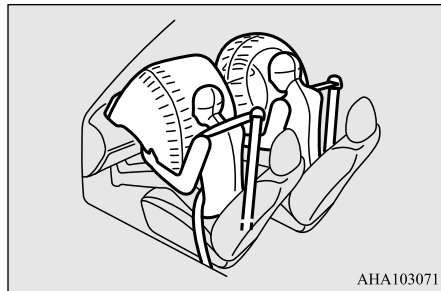

**Deployment of front airbags and driver's knee airbag\***

E00407502801

**The front airbags and driver's knee airbag ARE DESIGNED TO DEPLOY when...**

The front airbags and driver's knee airbag are designed to deploy when the vehicle suffers a moderate to severe frontal impact. The typical condition is shown in the illustration.

The front airbags and driver's knee airbag will deploy if the severity of impact is above the designed threshold level, comparable to an approximately 25 km/h collision when impacting straight into a solid wall that does not move or deform. If the severity of the impact is below the above threshold level, the front airbags and driver's knee airbag may not deploy. However, this threshold speed will be considerably higher if the vehicle strikes an object that absorbs the impact by either deforming or moving (for example, another stationary vehicle, pole or a guard rail).

**Driver's knee airbag system\***

E00412401117

The driver's knee airbag is located under the steering wheel. The driver's knee airbag is designed to deploy at the same time as the driver's front airbag.

## Supplemental restraint system (SRS)-airbag\*

4

Because frontal collisions can easily move you out of position, it is important to always properly wear your seat belts. Your seat belts will help keep you a safe distance from the steering wheel and instrument panel during the initial stages of airbag deployment. The initial stage of airbag inflation is the most forceful, and can possibly cause serious or fatal injuries. Moreover, the seat belts in your vehicle are your primary means of protection in a collision. The SRS airbags are designed to provide additional protection. Therefore, for your safety and the safety of all occupants, be sure to always properly wear your seat belts.

### **The front airbags and driver's knee airbag MAY NOT DEPLOY when...**

With certain types of frontal collisions, the vehicle's body structure is designed to absorb the shock to help protect the occupants from harm. (The vehicle body's front area may deform significantly as it absorbs the impact.) Under such circumstances, the front airbags and driver's knee airbag may not deploy irrespective of the deformation and damage to the vehicle body. Examples of some typical conditions are shown in the illustration.

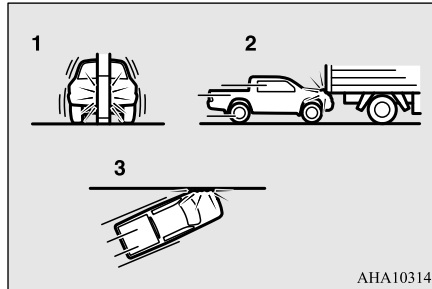

- 1- When colliding with a utility pole, tree or other narrow object.
- 2- Vehicle slides under the rear body of a truck
- 3- Oblique frontal impacts

Because the front airbags and driver's knee airbag do not protect the occupant in all types of frontal collisions, be sure to always properly wear your seat belts.

### **The front airbags and driver's knee airbag ARE NOT DESIGNED TO DEPLOY when...**

The front airbags and driver's knee airbag are not designed to deploy in conditions where they cannot typically provide protection to the occupant. Such conditions are shown in the illustration.

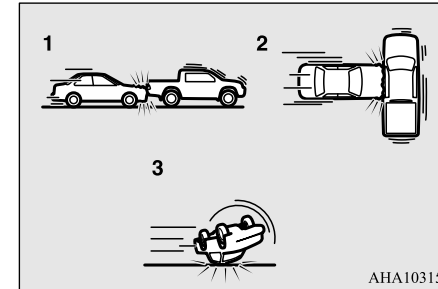

- 1- Rear end collisions
- 2- Side collisions
- 3- Vehicle rolls onto its side or roof

Because the front airbags and driver's knee airbag do not protect the occupant in all types of collisions, be sure to always properly wear your seat belts.

### **The front airbags and driver's knee airbag MAY DEPLOY when...**

The front airbags and driver's knee airbag may deploy if the bottom of the vehicle suffers a moderate to severe impact (undercarriage damage). Examples of some typical conditions are shown in the illustration.

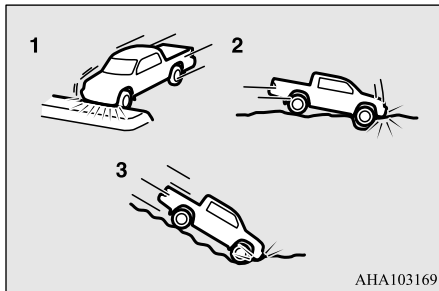

AHA103169

- 1- Collision with an elevated median/island or kerb
- 2- Vehicle travels over a deep hole/pothole
- 3- Vehicle drives down a steep slope and hits the ground

Because the front airbags and driver's knee airbag may deploy in certain types of unexpected impacts as shown in the illustration that can easily move you out of position, it is important to always properly wear your seat belts. Your seat belts will help keep you a safe distance from the steering wheel and instrument panel during the initial stages of airbag deployment. The initial stage of airbag inflation is the most forceful and can possibly cause serious or fatal injuries if you contact it at this stage.

**WARNING**

- Do not attach anything to the steering wheel's padded cover, such as badges or accessories. It might strike and injure an occupant if the airbag inflates.
- Do not set anything on, or attach anything to, the instrument panel above the glove box. It might strike and injure an occupant if the airbag inflates.

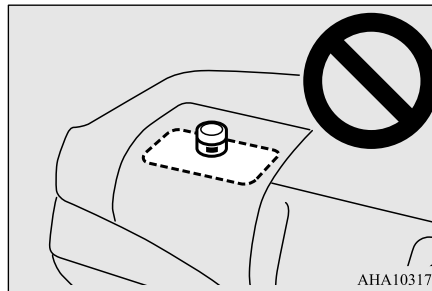

AHA103172

**WARNING**

- Do not attach accessories to, or put them in front of, the windscreen. These objects could restrict the airbag inflation, or strike and injure an occupant if the airbags inflate.

**WARNING**

- Do not attach additional keys or accessories (hard, pointed or heavy objects) to the ignition key. Such objects could prevent the driver's knee airbag from inflating normally or could be propelled to cause serious injury if the airbag inflates.
- Do not attach accessories to the lower portion of the driver's side instrument panel. Such objects could prevent the driver's knee airbag from inflating normally or could be propelled to cause serious injury if the airbag inflates.

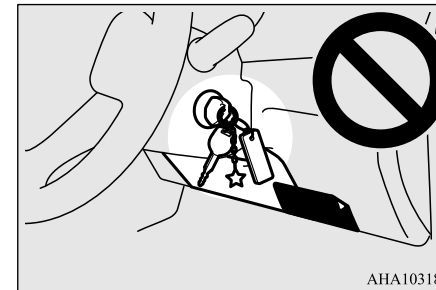

AHA103185

**WARNING**

- Do not put packages, pets or other objects between the airbags and the driver or front passenger. It could affect airbag performance, or could cause injury when the airbag inflates.

4

## Supplemental restraint system (SRS)-airbag\*

4

### **⚠ WARNING**

- Right after the airbag inflation, several airbag system components will be hot. Do not touch these components. There is a danger of being burnt.
- The airbag system is designed to work only once. Once the airbags have deployed, they will not work again. They must promptly be replaced and we recommend you to have the entire airbag system inspected by an authorised MITSUBISHI MOTORS dealer.

### Side airbag system\*

E00407601733

The side airbags (A) are contained in the driver and front passenger seatbacks. The side airbag is designed to inflate only on the side of the vehicle that is impacted, even with no passenger in the front seat.

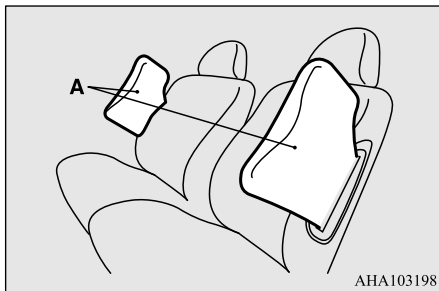

AHA103198

The label shown here is attached to the seatbacks with a side airbag.



AHA103202

### Curtain airbag system\*

E00409101758

The curtain airbags are contained in the front pillars and roof side rail. The curtain airbag is designed to inflate only on the side of the vehicle that is impacted, even with no passenger in the front seat or rear seat.

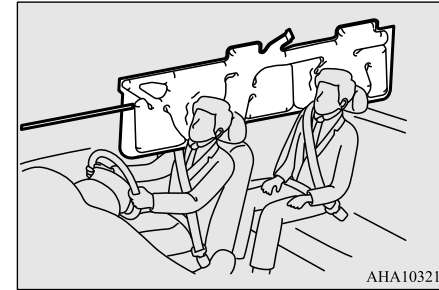

AHA103215

### Deployment of side airbags and curtain airbags

E00407702571

### The side airbags and curtain airbags ARE DESIGNED TO DEPLOY when...

The side airbags and curtain airbags are designed to deploy when the vehicle suffers a moderate to severe side impact to the middle of the passenger compartment. The typical condition is shown in the illustration.

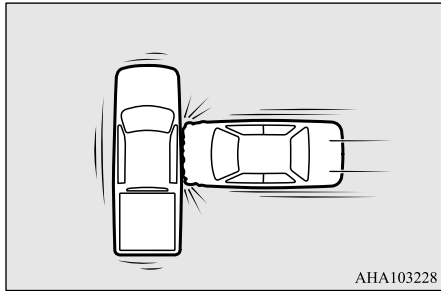

The seat belts in your vehicle are your primary means of protection in a collision. The SRS side airbags and curtain airbags are designed to provide additional protection. Therefore, for your safety and the safety of all occupants, be sure to always properly wear your seat belts.

**The side airbags and curtain airbags MAY NOT DEPLOY when...**

With certain types of side collisions, the vehicle's body structure is designed to absorb the shock to help protect the occupants from harm. (The vehicle body's side area may deform significantly as it absorbs the impact.) Under such circumstances, the side airbags and curtain airbags may not deploy irrespective of the deformation and damage to the

vehicle body. Examples of some typical conditions are shown in the illustration.

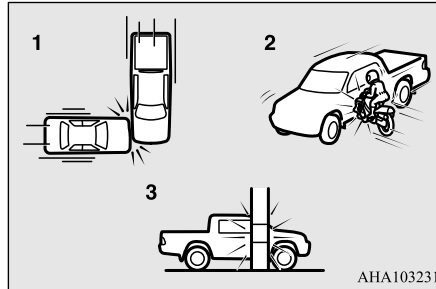

- 1- Side impacts in an area away from the passenger compartment
- 2- Motorcycle or other similar small vehicle collides with the side of vehicle
- 3- Collision with a utility pole, tree or other narrow object

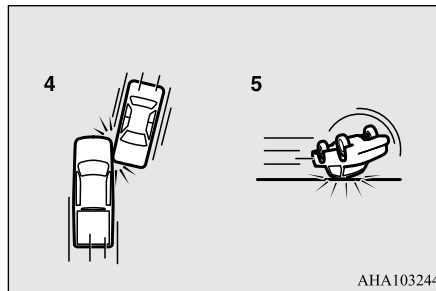

- 4- Oblique side impacts

- 5- Vehicle rolls onto its side or roof

Because the side airbags and curtain airbags do not protect the occupant in all types of side collisions, be sure to always properly wear your seat belts.

**4**

**The side airbags and curtain airbags ARE NOT DESIGNED TO DEPLOY when...**

The side airbags and curtain airbags are not designed to deploy in conditions where they cannot usually provide protection to the occupant. Typical conditions are shown in the illustration.

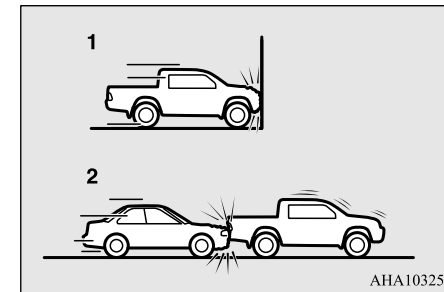

- 1- Head-on collisions
- 2- Rear end collisions



## Supplemental restraint system (SRS)-airbag\*

Because the side airbags and curtain airbags do not protect the occupant in all types of collisions, be sure to always properly wear your seat belts.

4

### ⚠ WARNING

- The side airbags and curtain airbags are designed to supplement the driver and passenger seat belts in certain side impacts. Seat belts should always be worn properly, and the driver and passenger should sit well back and upright without leaning against the window or door.
- The side airbag and curtain airbag inflate with great force. The driver and passenger should not put their arms out the window, and should not lean against the door, in order to reduce risk of serious or possible fatal injury from the deploying side airbag and curtain airbag.



### ⚠ WARNING

- Do not allow any rear seat occupant to hold onto the seatback of either front seat, in order to reduce risk of injury from the deploying side airbag. Special care should be taken with children.
- Do not place any objects near or in front of the seatback of either front seat. They could interfere with proper side airbag inflation, and also could cause injury if thrown free by side airbag deployment.
- Do not place stickers, labels or additional trim on the seatback of either front seat. They could interfere with proper side airbag inflation.
- Do not install seat covers on seats with side airbags. Do not re-cover seats that have side airbags. This could interfere with proper side airbag inflation.
- Do not attach a microphone (A) or any other device or object around the part where the curtain airbags (B) activate such as on the windscreen, side door glass, front and rear pillars and roof side or assist grips. When the curtain airbags inflate, the microphone or other device or object will be hurled with great force or the curtain airbags may not activate correctly, resulting in death or serious injury.

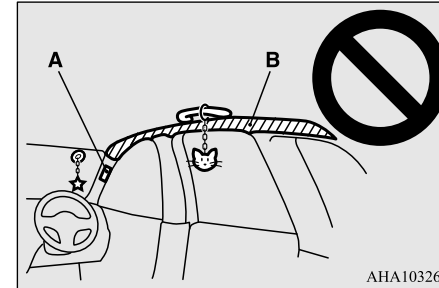

### ⚠ WARNING

- Do not put a hanger or any heavy or pointed object on the coat hook. If the curtain airbag was activated, any such item could be propelled away with great force and could prevent the curtain airbag from inflating correctly. Hang clothes directly on the coat hook (without using a hanger). Make sure there are no heavy or sharp objects in the pockets of clothes that you hang on the coat hook.
- Do not allow the child to lean against or close to the front door even if the child is seated in a child restraint system. The child's head should also not be leaned against or be close to the area where the side airbag and curtain airbag are located. It is dangerous if the side airbag and curtain airbag inflate. Failure to follow all of these instructions could lead to serious or fatal injury to the child.

**⚠ WARNING**

- We recommend work around and on the side airbags and curtain airbags system to be done by an authorised MITSUBISHI MOTORS dealer.

**SRS warning lamp/display**

E00407803423

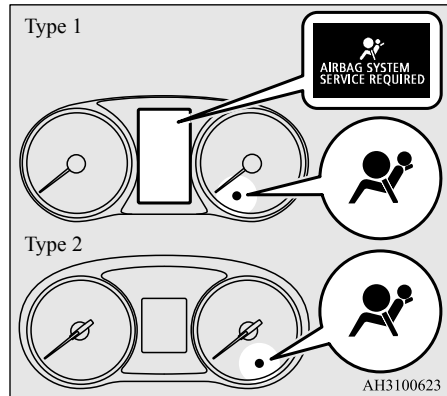

There is a supplemental restraint system (“SRS”) warning lamp on the instrument panel. The system checks itself every time the ignition switch is turned to the “ON” position or the operation mode is put in ON. The SRS warning lamp will come on for several seconds and then go out. This is normal and means the system is working properly.

If there is a problem involving one or more of the SRS components, the warning lamp will come on and stay on.

At the same time, the warning display will appear on the information screen in the multi information display (Type 1 only).

The SRS warning lamp/display is shared by the SRS airbag and the seat belt pre-tensioner system.

**⚠ WARNING**

- If any of the following conditions occur, there may be a problem with the SRS airbags and/or seat belt pre-tensioners, and they may not function properly in a collision or may suddenly activate without a collision:
  - Even when the ignition switch or the operation mode is in ON, the SRS warning lamp does not come on or it remains on.
  - The SRS warning lamp and/or the warning display comes on while driving.

The SRS airbags and seat belt pre-tensioners are designed to help reduce the risk of serious injury or death in certain collisions. If either of the above conditions occurs, immediately have your vehicle checked by an authorised MITSUBISHI MOTORS dealer.

**SRS servicing**

E00407902821

**⚠ WARNING**

- We recommend any maintenance performed on or near the components of the SRS to be performed by an authorised MITSUBISHI MOTORS dealer. Improper work on the SRS components or wiring could result in inadvertent deployment of the airbags, or could render the SRS inoperative; either situation could result in serious injury.
- Do not modify your steering wheel, seat belt retractor or any other SRS components. For example, replacement of the steering wheel, or modifications to the front bumper or body structure can adversely affect SRS performance and lead to possible injury.
- If your vehicle has received any damage, we recommend you to have the SRS inspected to ensure it is in proper working order.
- On vehicles with the side airbag, do not modify your front seats, centre pillar and centre console. It can adversely affect SRS performance and lead to possible injury.
- If you found any tear, scratch, crack or damage to the portion where the airbag is stored, you should have the SRS inspected by an authorised MITSUBISHI MOTORS dealer.

**4**

## Supplemental restraint system (SRS)-airbag\*

---

### **NOTE**

- If your vehicle has to be scrapped, do this in line with local legislation and contact an authorised MITSUBISHI MOTORS dealer to safely dismantle the airbag system.

**4**

## *Instruments and controls*

Instruments .....	5-2
Multi information display - Type 1 .....	5-3
Multi information display - Type 2 .....	5-18
Indicator lamp, warning lamp, and information screen display list (multi information display - Type 1) .....	5-27
Indicator and warning lamps (multi information display - Type 2) .....	5-48
Indicator lamps .....	5-49
Warning lamps .....	5-50
Information screen display (Vehicles equipped with the multi information display - Type 1) .....	5-52
Combination headlamps and dipper switch .....	5-53
Headlamp levelling switch* .....	5-59
Turn-signal lever .....	5-60
Hazard warning flasher switch .....	5-60
Front fog lamp switch* .....	5-61
Wiper and washer switch .....	5-61
Rear window demister switch* .....	5-65
Horn switch .....	5-66

**Instruments**

E00500103053

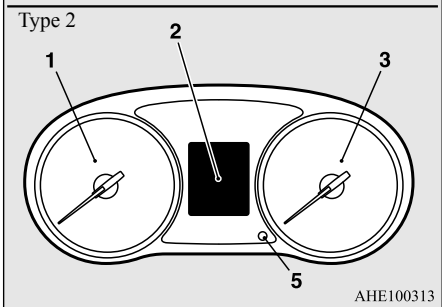
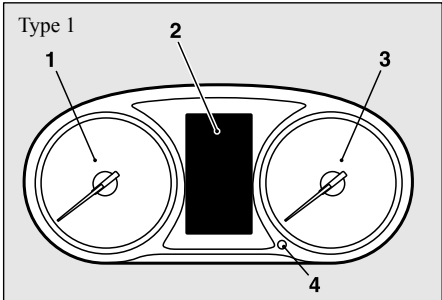

AHE100313

**1- Tachometer**

The tachometer indicates the engine speed (r/min). The tachometer can help you obtain more economical driving and also warns you of excessive engine speeds (Red zone).

- 2- Multi information display (Type 1: Color liquid crystal display type) → P.5-3  
Information screen display list (Type 1) → P.5-28  
Multi information display (Type 2: Mono-color liquid crystal display type) → P.5-18
- 3- Speedometer (km/h)
- 4- Rheostat illumination button (Type 1) → P.5-2
- 5- Multi information display switch (Type 2) → P.5-19

**CAUTION**

- When driving, watch the tachometer to make sure that the engine speed indication does not rise into the red zone (excessive engine r/min).

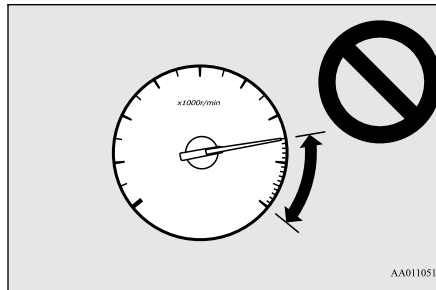

AA0110510

**Meter illumination control - Type 1**

E00531301116

Each time you press the rheostat illumination button, there is a sound and the brightness of the instruments changes.

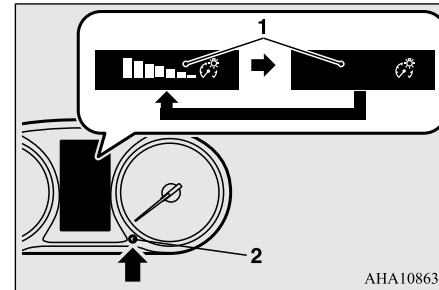

AHA108630

- 1- Brightness level
- 2- Rheostat illumination button

**NOTE**

- You can adjust to 8 different levels respectively for when the position lamps are illuminated and when they are not.
- If the vehicle is equipped with the automatic lamp control, when the lamp switch is in a position other than the “OFF” position, the meter illumination switches automatically to the adjusted brightness, depending on the brightness outside the vehicle.

## Multi information display - Type 1

### NOTE

- The brightness level of the instruments is stored when the ignition switch is turned off or the operation mode is put in OFF.
- If you press and hold the button for approximately 2 seconds or more when the position lamps are illuminated, the brightness level changes to the maximum level. Pressing and holding the button for approximately 2 seconds or more again returns the brightness level to the previous level.

### Multi information display - Type 1

E00519903480



Always stop the vehicle in a safe place before operating.

The following information is included on the multi information display: warnings, odometer, tripmeter, average and momentary fuel consumption, average speed etc.

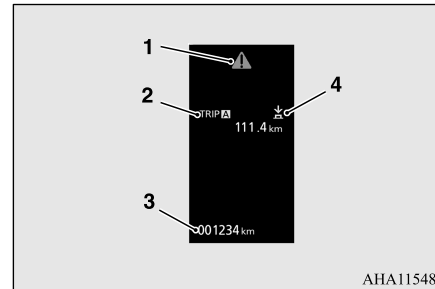
[When the ignition switch or the operation mode is OFF]





AHA115485

- 1- mark display → P.5-6
- 2-Information screen → P.5-4  
Interrupt display screen → P.5-6
- 3-Odometer → P.5-8
- 4- or  mark indicator → P.5-6

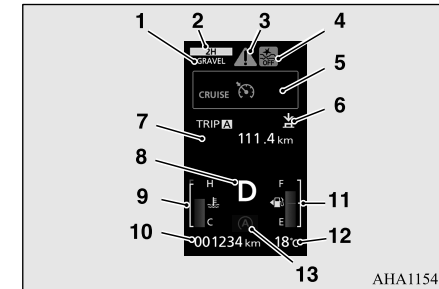
[When the ignition switch or the operation mode is ON]



AHA115498

- 1-Off Road mode indicator display\* → P.6-50
- 2-Drive mode indicator display\* (Vehicles with Easy Select 4WD) → P.6-36 (Vehicles with Super Select 4WD II) → P.6-43
- 3- mark display → P.5-6
- 4-Forward Collision Mitigation system (FCM) OFF indicator display\* → P.6-80  
Ultrasonic misacceleration Mitigation System (UMS) OFF indicator display\* → P.6-90
- 5-Cruise control indicator display\* → P.6-76
- 6- or  mark indicator → P.5-6
- 7-Information screen → P.5-5

Instruments and controls 5-3

5

## Multi information display - Type 1

- 8-Selector lever position display\* → P.6-30
- 9-Engine coolant temperature display → P.5-7
- 10-Odometer → P.5-8
- 11-Fuel remaining display → P.5-7
- 12-Outside temperature display → P.5-8
- 13-Auto Stop & Go (AS&G) indicator display → P.6-23
- Auto Stop & Go (AS&G) OFF indicator display → P.6-27

5

### NOTE

- The fuel units, outside temperature units, display language, and other settings can be changed. Refer to “Changing the function settings” on page 5-13.

## Multi information display switch

E00520001881

Each time the multi information display switch is operated, the buzzer sounds and the multi information display changes between information such as warnings, tripmeter, average and momentary fuel consumption, distance range etc.

It is also possible to change elements such as the language and units used on the multi

information display by operating the multi information display switch.

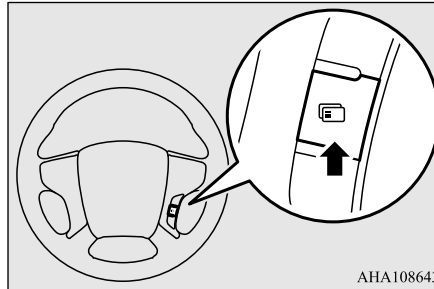

### NOTE

- Each time the multi information display back switch is operated, the buzzer sounds and the multi information display return to the position before pressing the multi information display switch.

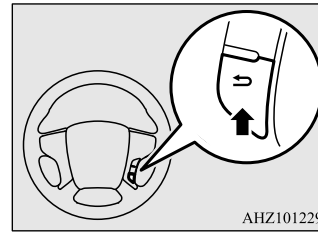

## Information screen (when the ignition switch or the operation mode is OFF)

E00520202125

Each time you lightly press the multi information display switch, the display screen switches in the following order.

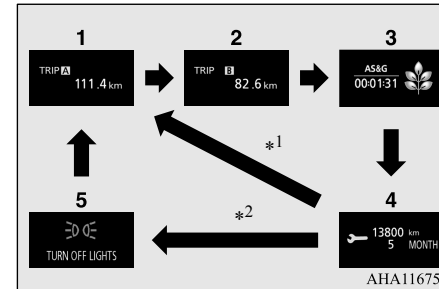

\*1: When there is no warning display

\*2: When there is a warning display

1- Tripmeter **A** → P.5-8

2- Tripmeter **B** → P.5-8

3- Auto Stop & Go (AS&G) monitor → P.5-12

ECO score display → P.5-12

4- Service reminder → P.5-8

5- Redisplay of a warning display screen → P.5-6

**Information screen (when the ignition switch is turned from the “LOCK” position to the “ON” position or the operation mode is changed from OFF to ON)**

E00520702348

When the ignition switch is turned to the “ON” position or the operation mode is put in ON, the display screen switches in the following order.

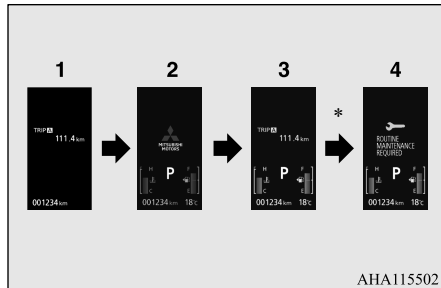

AHA115502

- \*: When the inspection time has arrived
- 1- Screen when the ignition switch or the operation mode is OFF
  - 2- System check screen → P.5-10
  - 3- Screen when the ignition switch or the operation mode is ON
  - 4- Service reminder → P.5-8

**Information screen (when the ignition switch or the operation mode is ON)**

E00521102163

Each time you lightly press the multi information display switch, the display screen switches in the following order.

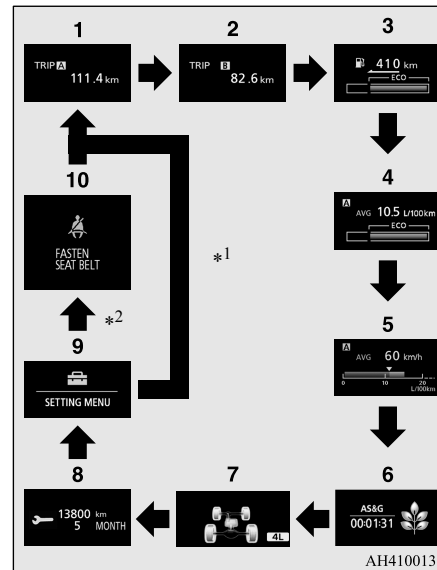

AH4100138

- \*1: When there is no warning display  
 \*2: When there is a warning display

- 1- Tripmeter **A** → P.5-8
- 2- Tripmeter **B** → P.5-8
- 3- Driving range display → P.5-10  
ECO drive assist display → P.5-12
- 4- Average fuel consumption display → P.5-10  
ECO drive assist display → P.5-12
- 5- Average speed display → P.5-11  
Momentary fuel consumption display → P.5-11
- 6- Auto Stop & Go (AS&G) monitor → P.5-12  
ECO score display → P.5-12
- 7- 2WD/4WD operation indicator display\*  
(Vehicles with Easy Select 4WD) → P.6-41  
(Vehicles with Super Select 4WD II) → P.6-46
- 8- Service reminder → P.5-8
- 9- Function setting screen → P.5-13
- 10- Redisplay of a warning display screen → P.5-6

**5**

**NOTE**

- While driving, the service reminder are not displayed even if you operate the multi information display switch. Always stop the vehicle in a safe place before operating.



## Multi information display - Type 1

5

### NOTE

- While driving, the function setting screen is not displayed even if you operate the multi information display switch.  
Always stop the vehicle in a safe place before operating and firmly apply the parking brake and put the gearshift lever into the “N” (Neutral) position (M/T) or the selector lever into the “P” (PARK) position (A/T). Refer to “Changing the function settings” on page 5-13.
- When there is information to be announced, such as a system fault, the buzzer sounds and the screen display is switched.  
Refer to “Interrupt display screen” on page 5-6.

### Interrupt display screen

E00522001944

### Warning display

When there is information to be announced, such as a system fault, the buzzer sounds and the information screen is switched to the warning display screen.

Refer to the warning list and take the necessary measures.

Refer to “Warning display list” on page 5-29. When the cause of the warning display is eliminated, the warning display goes out automatically.

5-6 Instruments and controls



### To return to the screen displayed before the warning display

Even if the cause of the warning display is not eliminated, you can return to the screen that was displayed before the warning display.

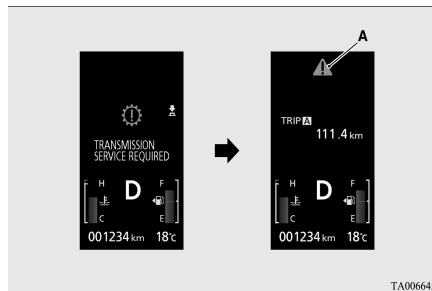
If you press the multi information display switch, the display screen switches to the screen that was displayed before the warning display and the  mark (A) is displayed.



### If you want to switch the display

Warning display screens with a  or  mark displayed in the upper right of the screen can be switched. If you want to switch the display, press the multi information display switch as follows.

: Press lightly.

: Press for approximately 2 seconds or more.

### Redisplay of a warning display screen

When the  mark is displayed, if you lightly press the multi information display switch a few times, the warning display screen you switched from is redisplayed.

### Other interrupt displays

The operation status of each system is displayed on the information screen.

Refer to the appropriate page in the warning display list for further details.

Refer to “Other interrupt displays” on page 5-44.

### mark display

E00533901060

This is displayed when you press the multi information display switch and return from the warning display screen to the previous screen.

This mark is also displayed if there is another warning other than the one displayed.

When the cause of the warning display is eliminated, the  mark goes out automatically.

**NOTE**

- When the  mark is displayed, the warning display screen can be redisplayed on the information screen.  
Refer to “Information screen (when the ignition switch or the operation mode is OFF)” on page 5-4.  
Refer to “Information screen (when the ignition switch or the operation mode is ON)” on page 5-5.

### Engine coolant temperature display

E00533801085



This indicates the engine coolant temperature.

If the coolant becomes hot,  will blink.

Pay careful attention to the engine coolant temperature display while you are driving.

**CAUTION**

- If the engine is overheating,  will blink. In this case, the bar graph is on the red zone. Immediately park the vehicle in a safe place and take the required measures. Refer to “Engine overheating” on page 8-4.

### Fuel remaining display

E00522202060

This displays the amount of fuel remaining.

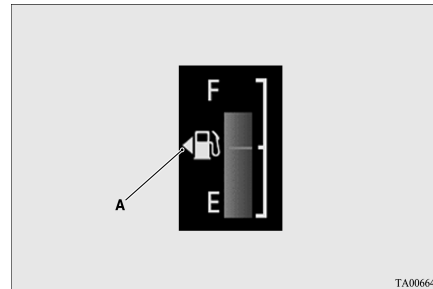

F (1) - Full  
E (0) - Empty

**NOTE**

- It may take several seconds to stabilise the display after refilling the tank.
- If fuel is added with the ignition switch or the operation mode is in ON, the fuel gauge may incorrectly indicate the fuel level.
- The arrow (A) indicates that the fuel tank filler door is located on the left side of the body.

5

### Fuel remaining warning display

E00522402482

When the fuel is reduced to approximately 10 litres, the information screen switches to the interrupt display of the fuel remaining warning display, and the  mark (B) on the fuel remaining display flashes slowly (approximately once per second). After a few seconds, the information screen returns from the fuel remaining warning display to the previous screen.

If the remaining fuel level is reduced further, the information screen switches to the fuel remaining warning display and the  mark (B) on the fuel remaining display flashes quickly (approximately twice per second).

## Multi information display - Type 1

5

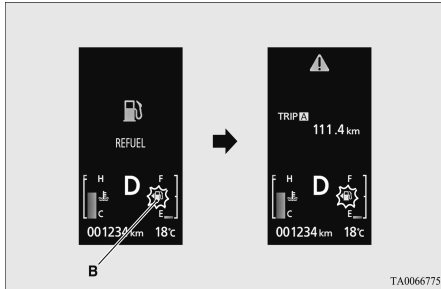

### CAUTION

- Do not drive with an extremely low fuel level; running out of fuel could cause damage to the fuel system.

### NOTE

- On inclines or curves, the display may be incorrect due to the movement of fuel in the tank.

### Outside temperature display

E00522101554

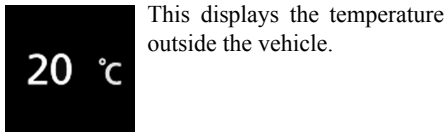

This displays the temperature outside the vehicle.

### NOTE

- The display setting can be changed to the preferred units (°C or °F). Refer to “Changing the function settings” on page 5-13.
- Depending on factors such as the driving conditions, the displayed temperature may vary from the actual outside temperature.

### Odometer

E00527800083

The odometer indicates the distance travelled.

### Tripmeter

E00527901124

The tripmeter indicates the distance travelled between two points.

Example usage of tripmeter **A** and tripmeter **B**

It is possible to measure two currently travelled distances, from home using tripmeter **A** and from a particular point on the way using tripmeter **B**.

### To reset the tripmeter

To return the display to 0, hold down the multi information display switch for approximately 2 seconds or more. Only the currently displayed value will be reset.

Example

If tripmeter **A** is displayed, only tripmeter **A** will be reset.

### NOTE

- When disconnecting the battery terminal, the memory of tripmeter **A** and **B** are cleared, and the display returns to “0”.

### Service reminder

E00522502177

Displays the approximate time until the next periodic inspection recommended by MITSUBISHI MOTORS. “---” is displayed when the inspection time has arrived.

## Multi information display - Type 1

### NOTE

- Depending on the vehicle specifications, the displayed time may differ from the next periodic inspection time recommended by MITSUBISHI MOTORS. In addition, the display settings for the next periodic inspection time can be modified. To modify the display settings, have it adjusted at an authorised MITSUBISHI MOTORS dealer. For more details, consult an authorised MITSUBISHI MOTORS dealer.

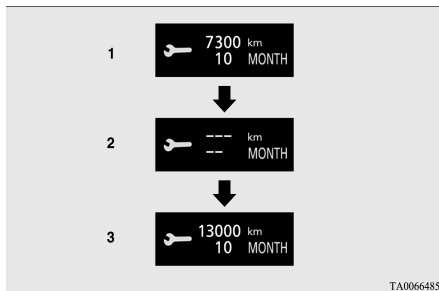

- Displays the time until the next periodic inspection.

### NOTE

- The distance is shown in units of 100 km (100 miles). The time is shown in units of months.

- This informs you that a periodic inspection is due. Please consult an authorised MITSUBISHI MOTORS dealer.

At that time, when the ignition switch is turned from the "LOCK" position to the "ON" position or the operation mode is changed from OFF to ON, the warning display is displayed for a few seconds on the information screen.





- After your vehicle is inspected at an authorised MITSUBISHI MOTORS dealer, it displays the time until the next periodic inspection.

### To reset

The "---" display can be reset while the ignition switch or the operation mode is in OFF. When the display is reset, the time until the next periodic inspection is displayed and the warning display is no longer displayed when the ignition switch is turned from the "LOCK" position to the "ON" position or the operation mode is changed from OFF to ON.

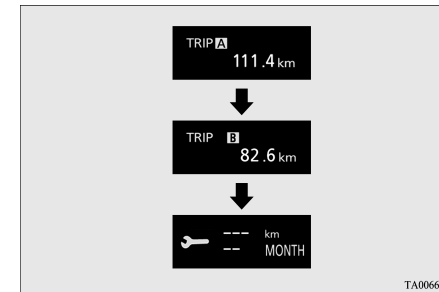
- When you lightly press the multi information display switch a few times, the information screen switches to the service reminder display screen.



- Press and hold the multi information display switch for approximately 2 seconds or more to display "" and make it flash. (If there is no operation for approximately 10 seconds with flashing, the display returns to the previous screen.)
- Lightly press the multi information display switch while the icon is flashing to change the display from "---" to "CLEAR". After this, the time until the next periodic inspection will be displayed.

## Multi information display - Type 1

5

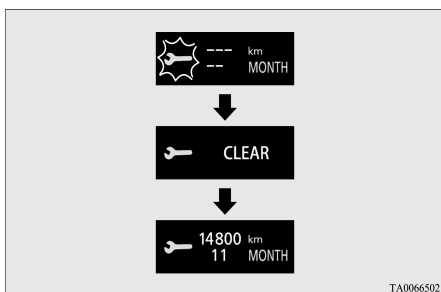

### CAUTION

- The customer is responsible for making sure that periodic inspection and maintenance are performed.
- Inspections and maintenance must be performed to prevent accidents and malfunctions.

### NOTE

- “---” display cannot be reset when the ignition switch or the operation mode is in ON.
- When “---” is displayed, after a certain distance and a certain period of time, the display is reset and the time until the next periodic inspection is displayed.
- If you accidentally reset the display, we recommend you to consult an authorised MITSUBISHI MOTORS dealer.

### System check screen

E00531001126

When the ignition switch is turned to the “ON” position or the operation mode is put in ON, the system check screen is displayed for approximately 4 seconds. If there is no fault, information screen (when the ignition switch or the operation mode is ON) is displayed. If there is a fault, the screen changes to warning display. Refer to “Warning display list” on page 5-29.

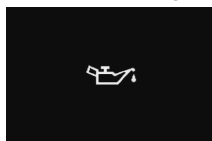

### NOTE

- The system check screen display varies depending on the customer’s equipment.

### Driving range display

E00538001095

This displays the approximate driving range (how many more kilometres or miles you can drive). When the driving range falls below approximately 50 km (30 miles), “---” is displayed.

Refuel as soon as possible.



### NOTE

- The driving range is determined based on the fuel consumption data. This may vary depending on the driving conditions and habits. Treat the distance displayed as just a rough guideline.
- When you refuel, the driving range display is updated. However, if you only add a small amount of fuel, the correct value will not be displayed. Fill with a full tank whenever possible.
- On rare occasions, the value displayed for the driving range may change if you are parked on an extremely steep incline. This is due to the movement of fuel in the tank and does not indicate any malfunction.
- The display setting can be changed to the preferred units (km or miles). Refer to “Changing the function settings” on page 5-13.

### Average fuel consumption display

E00531201157

This displays the average fuel consumption from the last reset to the present time.

The reset mode conditions for the average fuel consumption display can be switched between “Auto reset” and “Manual reset”. Refer to “Changing the reset mode for average fuel consumption and average speed” on page 5-14. For information on how to change the average fuel consumption display setting, refer to “Changing the function settings” on page 5-13.

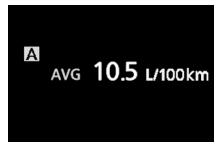

**NOTE**

- The average fuel consumption display can be reset separately for the auto reset mode and for the manual reset mode.
- “---” is displayed when the average fuel consumption cannot be measured.
- The initial (default) setting is “Auto reset mode”.
- The average fuel consumption will depend on the driving conditions (road conditions, how you drive, etc.). The displayed fuel consumption may vary from the actual fuel consumption. Treat the fuel consumption displayed as just a rough guideline.

**NOTE**

- The memory of the auto reset mode or manual reset mode for the average fuel consumption display is erased if the battery is disconnected.
- The display setting can be changed to the preferred units {km/L, mpg (US), mpg (UK) or L/100 km}. Refer to “Changing the function settings” on page 5-13.

### Average speed display

E00533701084

This displays the average speed from the last reset to the present time.

The reset mode conditions for the average speed display can be switched between “Auto reset” and “Manual reset”.

Refer to “Changing the reset mode for average fuel consumption and average speed” on page 5-14.

For the method for changing the average speed display setting, refer to “Changing the function settings” on page 5-13.

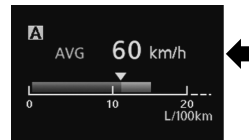

**NOTE**

- The average speed display can be reset separately for the auto reset mode and for the manual reset mode.
- “---” is displayed when the average speed cannot be measured.
- The initial (default) setting is “Auto reset mode”.
- The display setting can be changed to the preferred units (km/h or mph). Refer to “Changing the function settings” on page 5-13.
- The memory of the auto reset mode or manual reset mode for the average speed display is erased if the battery is disconnected.

### Momentary fuel consumption display

E00533601113

While driving, this displays the momentary fuel consumption, using a bar graph.

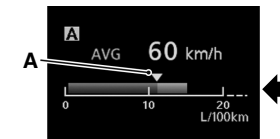

The “▼” mark (A) in the momentary fuel gauge shows the average fuel consumption. When the momentary fuel consumption surpasses the average fuel consumption, the

## Multi information display - Type 1

momentary fuel consumption is displayed with a green bar graph.

Be conscious of maintaining the momentary fuel consumption above the average fuel consumption, driving with the better fuel consumption can be possible.

5

### NOTE

- When the momentary fuel consumption cannot be measured, the bar graph is not displayed.
- The display setting can be changed to the preferred units {km/L, mpg (US), mpg (UK) or L/100 km}. Refer to “Changing the function settings” on page 5-13.
- It is possible to cancel the green bar graph. Refer to “Changing the function settings” on page 5-13.

### Auto Stop & Go (AS&G) monitor

E00531101097

The accumulated time the engine has been stopped by Auto Stop & Go (AS&G) system is displayed.

Refer to “Auto Stop & Go (AS&G) system” on page 6-22.

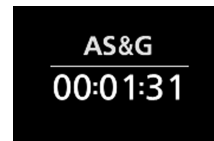

### NOTE

- When the ignition switch or the operation mode is ON again, the accumulated time will be reset.

### ECO drive assist display

E00531501248

This function displays how fuel-efficiently you are driving under different driving conditions.

The ECO drive assist display will change as follows if you do fuel-efficient driving using the accelerator in a way well matched with the vehicle speed.

### ECO drive level

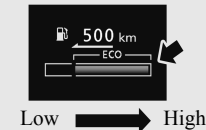

TA0066645

### NOTE

- On vehicles with A/T, the ECO drive assist is displayed only when vehicle is driving with the selector lever in the “D” (DRIVE) position or when vehicle is driving in the sport mode.

### ECO score display

E00531601311

ECO score indicates the points you have scored on fuel-efficient driving by the number of leaves as follows:

[When the ignition switch or the operation mode is ON]

The display shows the score you achieved in the last several minutes.

[When the ignition switch is turned off or the operation mode is put in OFF]

The display shows the overall ECO score the function has counted from the time when the ignition switch is turned to “ON” to the time when it is turned to “LOCK” or “ACC”, or from the time when the operation mode is set to “ON” to the time when it is set to “OFF”.

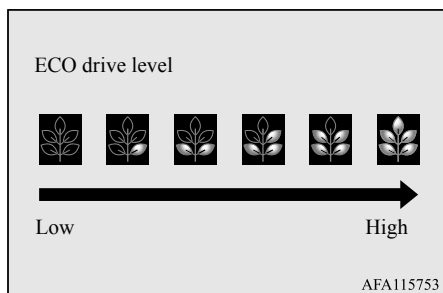

### Changing the function settings

E00522702241

The “Display language”, “Temperature unit”, “Fuel consumption unit”, and “Average fuel consumption and speed reset method” etc. setting can be modified as desired.

1. Stop the vehicle in a safe place.  
Firmly apply the parking brake and put the gearshift lever into the “N” (Neutral) position (M/T) or the selector lever into the “P” (PARK) position (A/T).

2. Lightly press the multi information display switch a few times to switch the information screen to the function setting screen.

Refer to “Information screen (when the ignition switch or the operation mode is ON)” on page 5-5.

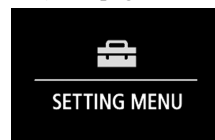

#### CAUTION

- For safety, stop the vehicle before operating. While driving, even if you operate the multi information display switch, the function setting screen is not displayed.

3. Press and hold the multi information display switch for approximately 2 seconds or more to switch from the setting mode screen to the menu screen.

### Multi information display - Type 1

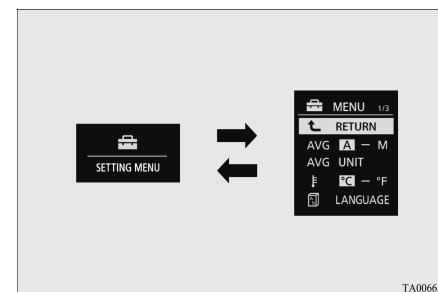

#### NOTE

- To return the menu screen to the function setting screen, press and hold the multi information display switch for approximately 2 seconds or more.
- If no operations are made within approximately 30 seconds of the menu screen being displayed, the display returns to the function setting screen.

4. Select the item to change on the menu screen and change to the desired setting. Refer to the following items for further details on the operation methods.

Refer to “Changing the reset mode for average fuel consumption and average speed” on page 5-14.

Refer to “Changing the fuel consumption display unit” on page 5-15.



## Multi information display - Type 1

5

Refer to “Changing the temperature unit” on page 5-15.

Refer to “Changing the display language” on page 5-16.

Refer to “Operation sound setting” on page 5-16.

Refer to “Changing the time until “REST REMINDER” is displayed” on page 5-16.  
Refer to “Changing the turn-signal sound” on page 5-17.

Refer to “Changing the momentary fuel consumption display” on page 5-17.

Refer to “Returning to the factory settings” on page 5-17.

### NOTE

- If the battery is disconnected, these function settings are reset from memory and is automatically to the factory settings.

### Changing the reset mode for average fuel consumption and average speed

E00522902357

The mode conditions for the average fuel consumption and average speed display can be switched between “Auto reset” and “Manual reset”.

1. Press and hold the multi information display switch for approximately 2 seconds or more to switch from the setting mode screen to the menu screen.

Refer to “Changing the function settings” on page 5-13.

2. Lightly press the multi information display switch to select **AVG A – M** “AVG (average fuel consumption and average speed setting)”.

3. Press and hold the multi information display switch for approximately 2 seconds or more to switch from A/1 (Auto reset mode) to M/2/P (Manual reset mode), or from M/2/P to A/1.

The setting is changed to the selected mode condition.

#### Manual reset mode

- When the average fuel consumption and average speed are being displayed, if you hold down the multi information display switch, the average fuel consumption and average speed displayed at that time are reset.
- When the following operation is performed, the mode setting is automatically switched from manual to auto.

[Except for vehicles equipped with the keyless operation system]

Turn the ignition switch from the “ACC” or “LOCK” position to the “ON” position.

[For vehicles equipped with the keyless operation system]

Change the operation mode from ACC or OFF to ON.

Switching to auto occurs automatically. If switching to manual mode is done, however, the data from the last reset is displayed.

#### Auto reset mode

- When the average fuel consumption and average speed are being displayed, if you hold down the multi information display switch, the average fuel consumption and average speed displayed at that time are reset.
- When the ignition switch or the operation mode is in the following conditions, the average fuel consumption display and average speed display are automatically reset.

[Except for vehicles equipped with the keyless operation system]

The ignition switch is in the “ACC” or “LOCK” position for approximately 4 hours or longer.

## Multi information display - Type 1

[For vehicles equipped with the keyless operation system]  
The operation mode is in ACC or OFF for approximately 4 hours or longer.

### NOTE

- The average fuel consumption display and average speed display can be reset separately for the auto reset mode and for the manual reset mode.
- The memory of the auto reset mode or manual reset mode for the average fuel consumption display and average speed display is erased if the battery is disconnected.

### Changing the fuel consumption display unit

E00523001879

The display unit for fuel consumption can be switched. The distance, speed, and amount units are also switched to match the selected fuel consumption unit.

1. Press and hold the multi information display switch for approximately 2 seconds or more to switch from the setting mode screen to the menu screen.  
Refer to “Changing the function settings” on page 5-13.

2. Lightly press the multi information display switch to select **AVG UNIT** “AVG UNIT (fuel consumption display setting)”.
3. Press and hold the multi information display switch for approximately 2 seconds or more to display “AVG UNIT”.
4. Lightly press the multi information display switch to select the units.
5. Press and hold the multi information display switch for approximately 2 seconds or more to change the setting to the selected unit.

### NOTE

- The display units for the driving range, the average fuel consumption, the average speed and the momentary fuel consumption are switched, but the units for the indicating needle (speedometer), the odometer and the trip-meter will remain unchanged.

The distance and speed units are also switched in the following combinations to match the selected fuel consumption unit.

Fuel consumption	Distance (driving range)	Speed (average speed)
L/100 km	km	km/h
mpg (US)	mile (s)	mph

Fuel consumption	Distance (driving range)	Speed (average speed)
mpg (UK)	mile (s)	mph
km/L	km	km/h

### Changing the temperature unit

E00523102053

**5**

The display unit for temperature can be switched.

1. Press and hold the multi information display switch for approximately 2 seconds or more to switch from the setting mode screen to the menu screen.  
Refer to “Changing the function settings” on page 5-13.
2. Lightly press the multi information display switch to select “**F**” (temperature unit setting).
3. Press and hold the multi information display switch for approximately 2 seconds or more to switch in from °C to °F, or from °F to °C.  
The setting is changed to the selected temperature unit.

## Multi information display - Type 1

5

### NOTE

- The temperature value on air conditioning panel is switched in conjunction with outside temperature display unit of the multi information display.  
However, “°C” or “°F” are not shown to temperature display of an air conditioning.

### Changing the display language

E00523201800

The language of the multi information display can be switched.

1. Press and hold the multi information display switch for approximately 2 seconds or more to switch from the setting mode screen to the menu screen.  
Refer to “Changing the function settings” on page 5-13.
2. Lightly press the multi information display switch to select  LANGUAGE “LANGUAGE” (language setting).
3. Press and hold the multi information display switch for approximately 2 seconds or more to display “LANGUAGE”.
4. Lightly press the multi information display switch to select the desired language.
5. If you hold down the multi information display switch for approximately 2 seconds or more, the setting is changed to the selected language.

5-16 Instruments and controls

### NOTE

- If “---” is selected in the language setting, a warning message is not displayed when there is a warning display or interrupt display.

### Operation sound setting

E00523401798

You can turn off the operation sounds of the multi information display switch and rheostat illumination button.

1. Press and hold the multi information display switch for approximately 2 seconds or more to switch from the setting mode screen to the menu screen.  
Refer to “Changing the function settings” on page 5-13.
2. Lightly press the multi information display switch to select  (operation sound setting).
3. Press and hold the multi information display switch for approximately 2 seconds or more to switch from ON (operation sound on) to OFF (operation sound off), or from OFF to ON.  
The setting is changed to the selected condition.

### NOTE

- The operation sound setting only deactivates the operation sound of the multi information display switch and rheostat illumination button. The warning display and other sounds cannot be deactivated.

### Changing the time until “REST REMINDER” is displayed

E00523501816

The time until the display appears can be changed.

1. Press and hold the multi information display switch for approximately 2 seconds or more to switch from the setting mode screen to the menu screen.  
Refer to “Changing the function settings” on page 5-13.
2. Lightly press the multi information display switch to select “ALARM” (rest time setting).
3. Press and hold the multi information display switch for approximately 2 seconds or more to display “ALARM”.
4. Lightly press the multi information display switch to select the time until the display.

- Press and hold the multi information display switch for approximately 2 seconds or more, the setting is changed to the selected time.

#### NOTE

- The drive time is reset when the ignition switch is turned off or the operation mode is put in OFF.

### Changing the turn-signal sound

E00529101481

It is possible to change the turn-signal sound.

- Press and hold the multi information display switch for approximately 2 seconds or more to switch from the setting mode screen to the menu screen.  
Refer to “Changing the function settings” on page 5-13.
- Lightly press the multi information display switch to select  (changing the turn-signal sound).
- Press and hold the multi information display switch for approximately 2 seconds or more to switch from 1 (turn-signal sound 1) to 2 (turn-signal sound 2), or from 2 to 1.  
The setting changes to the selected turn-signal sound.

### Changing the momentary fuel consumption display

E00529201408

It is possible to change the bar graph setting of the momentary fuel consumption display.

- Press and hold the multi information display switch for approximately 2 seconds or more to switch from the setting mode screen to the menu screen.  
Refer to “Changing the function settings” on page 5-13.
- Lightly press the multi information display switch to select  (changing the momentary fuel consumption display).
- Press and hold the multi information display switch for approximately 2 seconds or more to switch from ON (with the green bar graph) to OFF (without the green bar graph), or from OFF to ON.  
The setting changes to the selected bar graph setting.

### Returning to the factory settings

E00523602191

Many of the function settings can be returned to their factory settings.

- Press and hold the multi information display switch for approximately 2 seconds or more to switch from the setting mode screen to the menu screen.  
Refer to “Changing the function settings” on page 5-13.
- Lightly press the multi information display switch to select “RESET” (returning to the factory settings).
- When you press and hold the multi information display switch for approximately 5 seconds or more, the buzzer sounds and all of the function settings are returned to the factory settings.

5

#### NOTE

- The factory settings are as follows.
  - Average fuel consumption and average speed reset mode: A (Auto reset)
  - Fuel consumption display unit: L/100 km
  - Temperature unit: °C (Celsius)
  - Display language: THAI
  - Operation sounds: ON (Operation sounds on)
  - “REST REMINDER” display: OFF
  - Turn-signal sound: Turn-signal sound 1
  - Momentary fuel consumption with the green bar graph: ON

## Multi information display - Type 2

### Multi information display - Type 2

E00519903129

Always stop the vehicle in a safe place before operating.

**5**

The following information is included on the multi information display: odometer, tripmeter, average fuel consumption etc.

#### NOTE

- When the ignition switch or the operation mode is OFF, the selector lever position display, fuel remaining display, engine coolant temperature display and frozen road warning are not displayed.

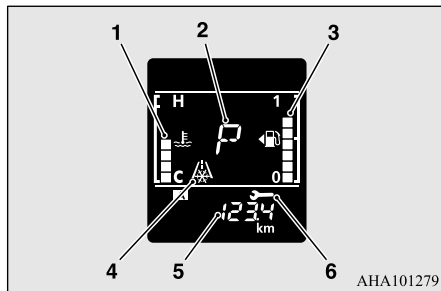

- 1- Engine coolant temperature display  
→ P.5-22
- 2- Selector lever position display\*  
→ P.6-30
- 3- Fuel remaining display → P.5-22
- 4- Frozen road warning\* → P.5-21
- 5- Information display → P.5-19
- 6- Service reminder → P.5-23

## Information display

E00528201371

Each time you lightly press the multi information display switch (A), the display switches in the following order.

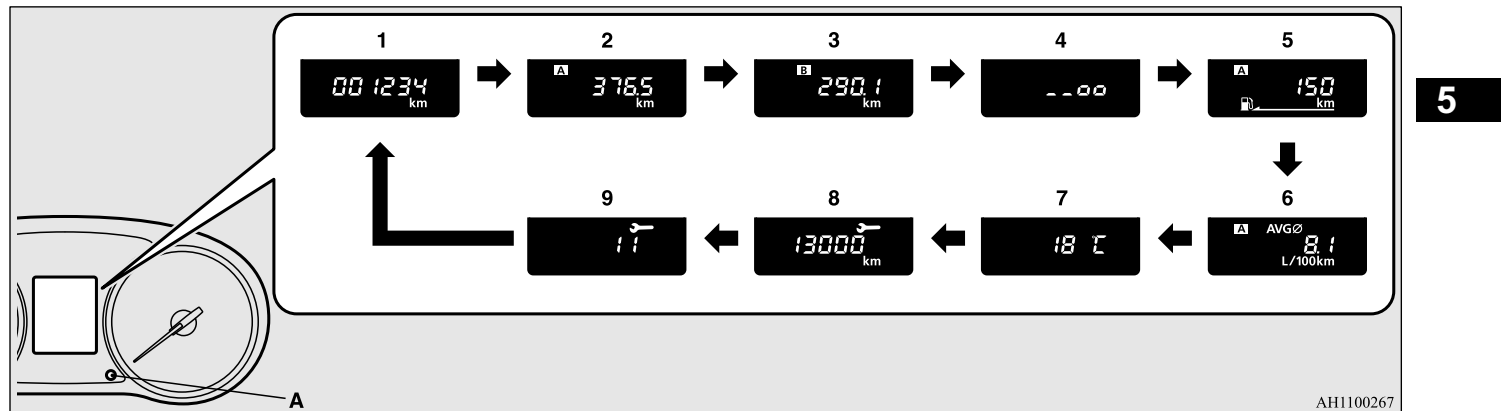

AH1100267

1- Odometer → P.5-20

2- Tripmeter **A** → P.5-203- Tripmeter **B** → P.5-20

4- Meter illumination control → P.5-20

5- Driving range display → P.5-20

6- Average fuel consumption display  
→ P.5-21

7- Outside temperature display\* → P.5-21

8- Service reminder (distance) → P.5-23

9- Service reminder (month) → P.5-23

### NOTE

- When the ignition switch or the operation mode is OFF, the driving range display, average fuel consumption display and outside temperature display are not displayed.
- While driving, the service reminder is not displayed even if you operate the multi information display switch.

## Multi information display - Type 2

### Odometer

E00527801123

The odometer indicates the distance travelled.

### Tripmeter

E00527901094

**5** The tripmeter indicates the distance travelled between two points.

Example usage of tripmeter **A** and tripmeter **B**

It is possible to measure two currently travelled distances, from home using tripmeter **A** and from a particular point on the way using tripmeter **B**.

### To reset the tripmeter

To return the display to 0, hold down the multi information display switch for about 2 seconds or more. Only the currently displayed value will be reset.

Example

If tripmeter **A** is displayed, only tripmeter **A** will be reset.

### NOTE

- When disconnecting the battery terminal, the memory of tripmeter **A** and **B** are cleared, and the display returns to “0”.

### Meter illumination control

E00537901068

Each time you press and hold the multi information display switch (2) for about 2 seconds or more, there is a sound and the brightness of the instruments changes.

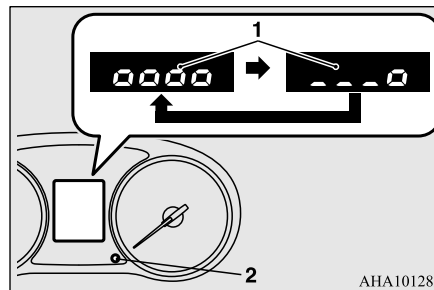

- 1- Brightness level
- 2- Multi information display switch

### NOTE

- You can adjust to 8 different levels respectively for when the position lamps are illuminated and when they are not. Each time you reduce two brightness levels, the segment display of the brightness level decreases one by one.
- If the vehicle is equipped with the automatic lamp control, when the lamp switch is in a position other than the “OFF” position, the meter illumination switches automatically to the adjusted brightness, depending on the brightness outside the vehicle.
- The brightness level of the instruments is stored when the ignition switch is turned off or the operation mode is put in OFF.

### Driving range display

E00538000014

This displays the approximate driving range (how many more kilometres or miles you can drive). When the driving range falls below approximately 50 km (30 miles), “---” is displayed.

### NOTE

- The driving range is determined based on the fuel consumption data. This may vary depending on the driving conditions and habits. Treat the distance displayed as just a rough guideline.

**NOTE**

- When you refuel, the driving range display is updated. However, if you only add a small amount of fuel, the correct value will not be displayed. Fill with a full tank whenever possible.
- On rare occasions, the value displayed for the driving range may change if you are parked on an extremely steep incline. This is due to the movement of fuel in the tank and does not indicate any malfunction.
- The display setting can be changed to the preferred units (km or miles). Refer to “Changing the function settings” on page 5-24.

**Average fuel consumption display**

E00531200033

This displays the average fuel consumption from the last reset to the present time. The reset mode conditions for the average fuel consumption display can be switched between “Auto reset” and “Manual reset”. For information on how to change the average fuel consumption display setting, refer to “Changing the function settings” on page 5-24.

**NOTE**

- The average fuel consumption display can be reset separately for the auto reset mode and for the manual reset mode.
- “---” is displayed when the average fuel consumption cannot be measured.
- The initial (default) setting is “Auto reset mode”.
- The average fuel consumption will depend on the driving conditions (road conditions, how you drive, etc.). The displayed fuel consumption may vary from the actual fuel consumption. Treat the fuel consumption displayed as just a rough guideline.
- The memory of the manual reset mode or auto reset mode for the average fuel consumption display is erased if the battery is disconnected.
- The display setting can be changed to the preferred units {km/L, L/100 km, mpg}. Refer to “Changing the function settings” on page 5-24.

**Outside temperature display\***

E00533501079

This displays the temperature outside the vehicle.

**NOTE**

- The display setting can be changed to the preferred units (°C or °F). Refer to “Changing the function settings” on page 5-24.
- Depending on factors such as the driving conditions, the displayed temperature may vary from the actual outside temperature.

**5**

**Frozen road warning\***

E00533401065

If the outside air temperature drops below approx. 3°C (37 °F), the alarm sounds and the outside air temperature warning symbol (A) flashes for about 10 seconds.

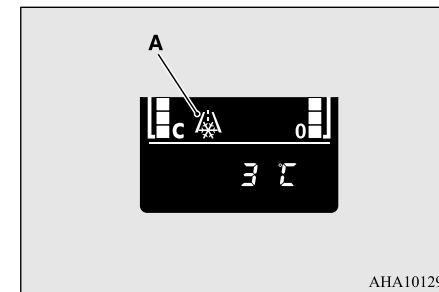



## Multi information display - Type 2

### ⚠ CAUTION

- There is a danger the road might be icy, even when this symbol is not flashing, so please take care when driving.

5

### Engine coolant temperature display

E00533801115

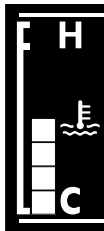

This indicates the engine coolant temperature.

If the coolant becomes hot, “” will blink. Pay careful attention to the engine coolant temperature display while you are driving.

### ⚠ CAUTION

- If the engine is overheating, “” will blink. In this case, the bar graph is on the red zone. Immediately park the vehicle in a safe place and take the required measures. Refer to “Engine overheating” on page 8-4.

### Fuel remaining display

E00522201816

The fuel remaining display indicates the fuel level in the fuel tank when the ignition switch or the operation mode is ON.

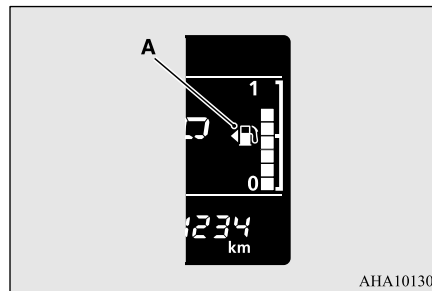

AHA101309

- 1- Full
- 0- Empty

### 📖 NOTE

- It may take several seconds to stabilise the display after refilling the tank.
- If fuel is added with the ignition switch or the operation mode is ON, the fuel gauge may incorrectly indicate the fuel level.
- The fuel lid mark (A) indicates that the fuel tank filler door is located on the left side of the vehicle.

### Fuel remaining warning display

E00522402381

If the remaining fuel level is approximately 10 litres or less (one segment displayed) when the ignition switch is turned to the “ON” position or the operation mode is changed to ON, the last segment of the fuel gauge flashes. If the remaining fuel level is reduced further, the last segment of the fuel gauge goes out and “” flash.

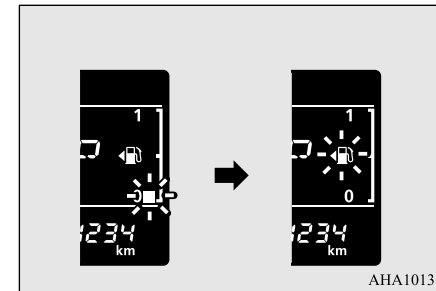

AHA101312

### ⚠ CAUTION

- Do not drive with an extremely low fuel level; running out of fuel could cause damage to the fuel system.

## Multi information display - Type 2

**NOTE**

- On inclines or curves, the display may be incorrect due to the movement of fuel in the tank.

### Service reminder

E00522502089

Displays the approximate time until the next periodic inspection that MITSUBISHI MOTORS recommends. “---” is displayed when the inspection time has arrived. The spanner mark indicates the periodic inspection.

**NOTE**

- Depending on the vehicle specifications, the displayed time until the next periodic inspection may differ from that of MITSUBISHI MOTORS recommends. In addition, the display settings for the next periodic inspection time can be modified. To modify the display settings, have it adjusted at an authorised MITSUBISHI MOTORS dealer. For more details, contact an authorised MITSUBISHI MOTORS dealer.

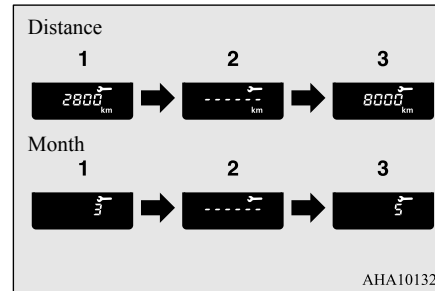

1. Displays the time until the next periodic inspection.

**NOTE**

- The distance is shown in units of 100 km (100 miles). The time is shown in units of months.

- This informs you that a periodic inspection is due. Please consult an authorised MITSUBISHI MOTORS dealer.
- After your vehicle is inspected at an authorised MITSUBISHI MOTORS dealer, it displays the time until the next periodic inspection.

### To reset

The “---” display can be reset while the ignition switch or the operation mode is in OFF.

- When you lightly press the multi information display switch a few times, the information display switches to the service reminder display.

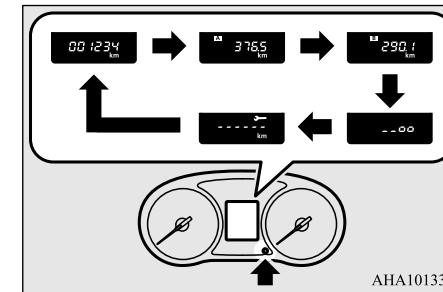

- Press and hold the multi information display switch for about 2 seconds or more to make the spanner mark start flashing. (If there is no operation for about 10 seconds with flashing, the display will revert to its original indication.)
- Lightly press the multi information display switch while the icon is flashing to change the display from “---” to “cLEAR”. After this, the time until the next periodic inspection will be displayed.

5

5

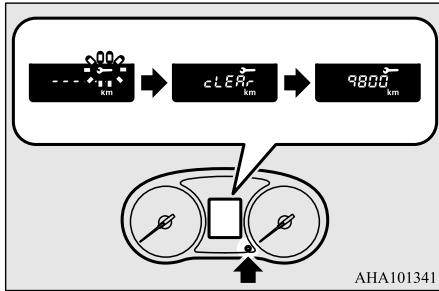

**CAUTION**

- The customer is responsible for making sure that periodic inspection and maintenance are performed. Inspections and maintenance must be performed to prevent accidents and malfunctions.

**NOTE**

- “---” display cannot be reset when the ignition switch or the operation mode is in ON.
- When “---” is displayed, after a certain distance and a certain period of time, the display is reset and the time until the next periodic inspection is displayed.
- If you accidentally reset the display, consult an authorised MITSUBISHI MOTORS dealer.

### Changing the function settings

E00522700595

The “Average fuel consumption reset mode”, “Fuel consumption unit” and “Temperature unit” setting can be modified as desired, when the ignition switch or the operation mode is ON.

**CAUTION**

- The driver should not operate the display while the vehicle is in motion.
- When operating the system, stop the vehicle in a safe area.

### Changing the reset mode for average fuel consumption

E00522902432

The mode conditions for the average fuel consumption display can be switched between “Auto reset” and “Manual reset”.

1. When you lightly press the multi information display switch a few times, the information display switches to the driving range display. Refer to “Information display” on page 5-19.

2. Each time you press the multi information display switch for 2 seconds or more on driving range display, you can switch reset mode for average fuel consumption. (A: Auto reset mode, B: Manual reset mode)

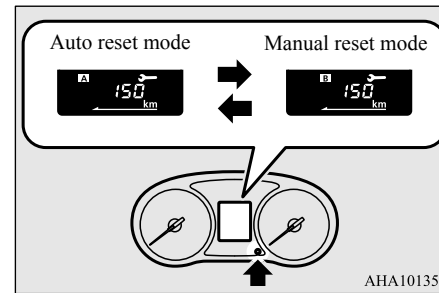

### Manual reset mode

- When the average fuel consumption is being displayed, if you hold down the multi information display switch, the average fuel consumption displayed at that time is reset.
- When the following operation is performed, the mode setting is automatically switched from manual to auto. [Except for vehicles equipped with the keyless operation system] Turn the ignition switch from the “ACC” or “LOCK” position to the “ON” position.

[For vehicles equipped with the keyless operation system]  
Change the operation mode from ACC or OFF to ON.

Switching to auto occurs automatically. If switching to manual mode is done, however, the data from the last reset is displayed.

#### Auto reset mode

- When the average fuel consumption is being displayed, if you hold down the multi information display switch, the average fuel consumption displayed at that time are reset.
- When the ignition switch or the operation mode is in the following conditions, the average fuel consumption display is automatically reset.

[Except for vehicles equipped with the keyless operation system]  
The ignition switch is in the “ACC” or “LOCK” position for about 4 hours or longer.

[For vehicles equipped with the keyless operation system]  
The operation mode is in ACC or OFF for about 4 hours or longer.

#### NOTE

- The average fuel consumption display can be reset separately for the auto reset mode and for the manual reset mode.
- The memory of the manual reset mode or auto reset mode for the average fuel consumption display is erased if the battery is disconnected.
- The initial (default) setting is “Auto reset mode”.

### Changing the fuel consumption display unit

E00523001808

The display unit for fuel consumption can be switched. The distance and amount units are also switched to match the selected fuel consumption unit.

1. When you lightly press the multi information display switch a few times, the information display switches to the average fuel consumption display.  
Refer to “Information display” on page 5-19.
2. Press and hold the multi information display switch for about 5 seconds or more until buzzer sound is heard twice.

### Multi information display - Type 2

3. Press and hold the multi information display switch to switch in sequence from “km/L” → “L/100 km” → “mpg” → “km/L”.

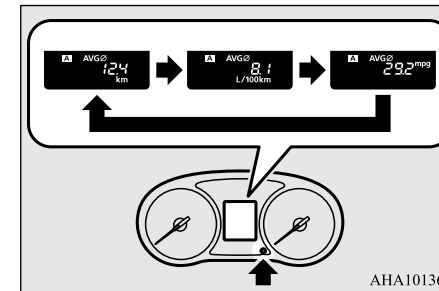

#### NOTE

- The display units for the driving range, the average fuel consumption are switched, but the units for the indicating needle (speedometer), the odometer, the tripmeter and the service reminder will remain unchanged.
- The memory of the unit setting is erased if the battery is disconnected, and it returns automatically to factory setting.

The distance units is also switched in the following combinations to match the selected fuel consumption unit.

## Multi information display - Type 2

---

Fuel consumption	Distance (driving range)
km/L	km
L/100 km	km
mpg	mile (s)

### 5

## Changing the temperature unit

E00523102082

The display unit for outside temperature can be switched.

1. When you lightly press the multi information display switch a few times, the information display switches to the outside temperature display.  
Refer to “Information display” on page 5-19.
2. Each time you press the multi information display switch for 2 seconds or more on outside temperature display, you can switch from °C to °F or from °F to °C unit of outside temperature display.

### NOTE

- The temperature value on air conditioning panel is switched in conjunction with outside temperature display unit of the multi information display.  
However, “°C” or “°F” are not shown to temperature display of an air conditioning.

## Indicator lamp, warning lamp, and information screen display list (multi information display - Type 1)

E00523701254

### Indicator and warning lamp list

E00523802731

5

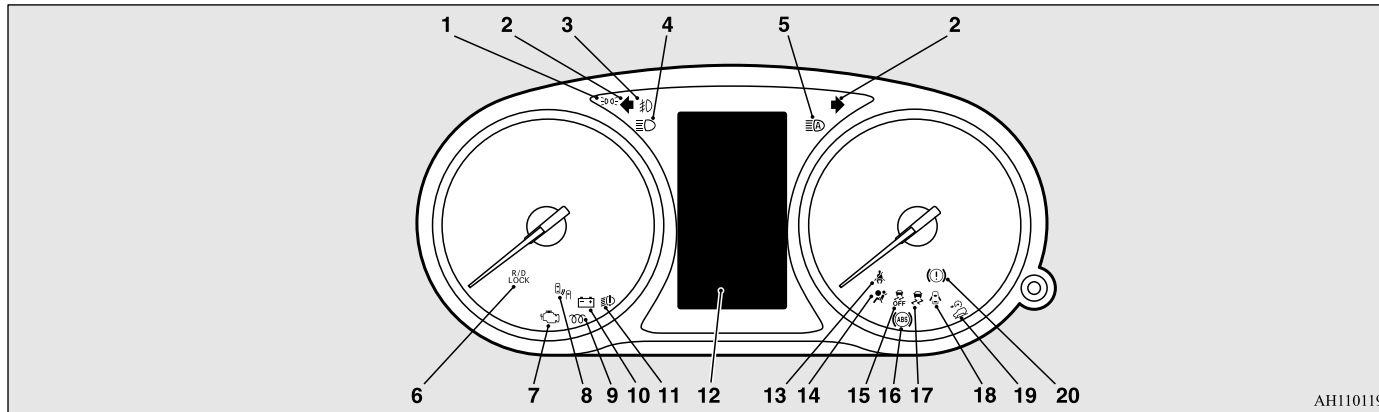

AH1101192

- |  |  |   |
|--|--|---|
| 1- Position lamp indicator lamp → P.5-49                               | 6- Rear differential lock indicator lamp* →P.6-52    | 11- LED headlamp warning lamp →P.5-52                                     |
| 2- Turn-signal indicator lamps/Hazard warning indicator lamps → P.5-49 | 7- Check engine warning lamp → P.5-51                | 12- Information screen display list → P.5-28                              |
| 3- Front fog lamp indicator lamp → P.5-49                              | 8- Blind Spot Warning (BSW) indicator lamp* → P.6-97 | 13- Seat belt warning lamp *→ P.4-8                                       |
| 4- High-beam indicator lamp → P.5-49                                   | 9- Diesel preheat indicator lamp → P.5-49            | 14- Supplemental restraint system (SRS) warning lamp → P.4-25             |
| 5- Automatic High Beam (AHB) indicator lamp* → P.5-56                  | 10- Charge warning lamp → P.5-51                     | 15- Active Stability & Traction Control (ASTC) OFF indicator lamp →P.6-74 |

## Indicator lamp, warning lamp, and information screen display list (multi information display - Type 1)

---

- 16- Anti-lock brake system (ABS) warning lamp → P.6-70
- 17- Active Stability & Traction Control (ASTC) indicator lamp →P.6-74
- 18- Door-ajar warning lamp → P.5-52
- 19- Hill Descent Control indicator lamp\* → P.6-67
- 20- Brake warning lamp → P.5-50

**5**

### Information screen display list

---

E00523901445

When there is information to be announced, such as lamp reminder, the buzzer sounds and the screen switches to the displays shown below. Refer to the appropriate page and take the necessary measures.

When the cause of the warning display is eliminated, the warning display goes out automatically.

Refer to “Warning display list” on page 5-29.

Refer to “Other interrupt displays” on page 5-44.







#### **NOTE**

- A warning may be displayed on the information screen and the buzzer may sound in the following rare cases.
    - This is caused by the system picking up interference such as noise or strong electromagnetic waves, and is not a functional problem.
    - An extremely strong electromagnetic wave is received from a source such as an illegal radio set, a spark from a wire, or a radar station.
    - Abnormal voltage or a static electricity discharge is generated by the operation of installed electrical equipment (including after-market parts).
- If the warning display appears many times, consult an authorised MITSUBISHI MOTORS dealer.

Indicator lamp, warning lamp, and information screen display list (multi information display - Type 1)

**Warning display list**

E00524003085

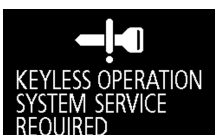





Screen	Cause	Solution (Reference)
 <p>IMMOBILIZER SYSTEM SERVICE REQUIRED</p>	<ul style="list-style-type: none"> <li>● There is a fault in the electronic immobilizer (Anti-theft starting system).</li> </ul>	<p>Refer to “Electronic immobilizer (Anti-theft starting system)” on page 3-3.</p>
 <p>ELECTRICAL SYSTEM SERVICE REQUIRED</p>	<ul style="list-style-type: none"> <li>● There is a fault in the electrical system.</li> </ul>	<ul style="list-style-type: none"> <li>● Immediately stop the vehicle in a safe place and consult an authorised MITSUBISHI MOTORS dealer.</li> </ul>
 <p>KEY BATTERY LOW</p>  <p>KEY NOT DETECTED</p>  <p>KEY STILL IN VEHICLE</p>  <p>CHECK DOORS</p>  <p>KEYLESS OPERATION SYSTEM SERVICE REQUIRED</p>	<ul style="list-style-type: none"> <li>● There is a fault in the keyless operation system.</li> </ul>	<p>Refer to “Keyless operation system” on page 3-8.</p>

**5**







Indicator lamp, warning lamp, and information screen display list (multi information display - Type 1)

5

Screen	Cause	Solution (Reference)
 <p>FASTEN SEAT BELT</p>	<ul style="list-style-type: none"> <li>You turned the ignition switch to the “ON” position or put the operation mode in ON without fastening your seat belt.</li> </ul>	<ul style="list-style-type: none"> <li>Fasten your seat belt properly. Refer to “Seat belt reminder” on page 4-8.</li> </ul>
 <p>AIRBAG SYSTEM SERVICE REQUIRED</p>	<ul style="list-style-type: none"> <li>There is a fault in the SRS airbag or the pre-tensioner system.</li> </ul>	<ul style="list-style-type: none"> <li>Contact an authorised MITSUBISHI MOTORS dealer to have the system checked, immediately. Refer to “SRS warning lamp/display” on page 4-25.</li> </ul>
 <p>POSSIBLE ICY ROADS</p>	<ul style="list-style-type: none"> <li>The outside temperature is 3 °C (37 °F) or less.</li> </ul>	<ul style="list-style-type: none"> <li>Be careful of ice on the road.</li> <li>The road can be icy even when this warning is not displayed, so drive carefully.</li> </ul>
 <p>REFUEL</p>	<ul style="list-style-type: none"> <li>The fuel is running low.</li> </ul>	<ul style="list-style-type: none"> <li>Refuel as soon as possible. Refer to “Fuel remaining warning display” on page 5-7.</li> </ul>
 <p>FUEL SYSTEM SERVICE REQUIRED</p>	<ul style="list-style-type: none"> <li>There is a fault in the fuel system.</li> </ul>	<ul style="list-style-type: none"> <li>Have your vehicle inspected at an authorised MITSUBISHI MOTORS dealer.</li> </ul>
 <p>RELEASE PARKING BRAKE</p>	<ul style="list-style-type: none"> <li>You are driving with the parking brake still applied.</li> </ul>	<ul style="list-style-type: none"> <li>Release the parking brake. Refer to “Brake warning display” on page 5-52.</li> </ul>





Indicator lamp, warning lamp, and information screen display list (multi information display - Type 1)

Screen	Cause	Solution (Reference)
 BRAKE SYSTEM SERVICE REQUIRED	<ul style="list-style-type: none"> <li>● The brake fluid level in the reservoir has fallen to a low level.</li> <li>● There is a fault in the brake system.</li> </ul>	<ul style="list-style-type: none"> <li>● Immediately stop the vehicle in a safe place and consult an authorised MITSUBISHI MOTORS dealer. Refer to “Brake warning display” on page 5-52.</li> </ul>
 CHARGING SYSTEM SERVICE REQUIRED	<ul style="list-style-type: none"> <li>● There is a fault in the charging system.</li> </ul>	<ul style="list-style-type: none"> <li>● Immediately stop the vehicle in a safe place and consult your nearest authorised MITSUBISHI MOTORS dealer. Refer to “Charge warning display” on page 5-53.</li> </ul>
 LOW OIL PRESSURE	<ul style="list-style-type: none"> <li>● There is a fault in the engine oil circulation system.</li> </ul>	<ul style="list-style-type: none"> <li>● Immediately stop the vehicle in a safe place and consult your nearest authorised MITSUBISHI MOTORS dealer. Refer to “Oil pressure warning display” on page 5-53.</li> </ul>
 TURN OFF LIGHTS	<ul style="list-style-type: none"> <li>● You have forgotten to turn off the lamps.</li> </ul>	Refer to “Lamps (headlamps, fog lamp, etc.) auto-cutout function” on page 5-55.
 LED HEADLIGHT SERVICE REQUIRED	<ul style="list-style-type: none"> <li>● There is a fault in the LED headlamps.</li> </ul>	<ul style="list-style-type: none"> <li>● Please consult an authorised MITSUBISHI MOTORS dealer. Refer to “LED headlamp warning lamp” on page 5-52.</li> </ul>





5

Indicator lamp, warning lamp, and information screen display list (multi information display - Type 1)

5

Screen	Cause	Solution (Reference)
	<ul style="list-style-type: none"> <li>● The driver's door is open when the operation mode is in any mode other than OFF.</li> </ul>	<ul style="list-style-type: none"> <li>● Put the operation mode in OFF. Refer to "Operation mode ON reminder system" on page 6-16.</li> </ul>
	<ul style="list-style-type: none"> <li>● An attempt was made to lock all the doors when the operation mode is in any mode other than OFF.</li> </ul>	<ul style="list-style-type: none"> <li>● Put the operation mode in OFF. Refer to "Operation mode OFF reminder system" on page 6-16.</li> </ul>
	<ul style="list-style-type: none"> <li>● There is a fault in the steering wheel lock.</li> </ul>	<ul style="list-style-type: none"> <li>● Immediately stop the vehicle in a safe place and consult an authorised MITSUBISHI MOTORS dealer. Refer to "Steering wheel lock" on page 6-16.</li> </ul>
	<ul style="list-style-type: none"> <li>● The steering wheel is locked.</li> </ul>	<ul style="list-style-type: none"> <li>● Press the engine switch while turning steering wheel. Refer to "Steering wheel lock" on page 6-16.</li> </ul>
	<ul style="list-style-type: none"> <li>● The engine is stopped while the selector lever is in a position other than the "P" (PARK) position.</li> </ul>	<ul style="list-style-type: none"> <li>● Place the selector lever in the "P" (PARK) position to put the operation mode in OFF.</li> </ul>
	<ul style="list-style-type: none"> <li>● The driver's door is opened with the steering wheel unlocked.</li> </ul>	<ul style="list-style-type: none"> <li>● Refer to "Steering wheel lock" on page 6-16.</li> </ul>





Indicator lamp, warning lamp, and information screen display list (multi information display - Type 1)

Screen	Cause	Solution (Reference)
 KEY NOT DETECTED INSERT KEY INTO KEY SLOT	<ul style="list-style-type: none"> <li>The keyless operation key is not detected.</li> </ul>	<ul style="list-style-type: none"> <li>Insert the keyless operation key into the key slot. Refer to “If the keyless operation key is not operating properly” on page 6-21.</li> </ul>
 REMOVE KEY FROM KEY SLOT	<ul style="list-style-type: none"> <li>You have forgotten to remove the keyless operation key from the key slot.</li> </ul>	<ul style="list-style-type: none"> <li>Remove the keyless operation key from the key slot. Refer to “Keyless operation key reminder” on page 6-22.</li> </ul>
 TRANSMISSION OVERHEATING SLOW DOWN	<ul style="list-style-type: none"> <li>The A/T fluid temperature is too high.</li> </ul>	Refer to “When a malfunction occurs in the A/T” on page 6-33.
 TRANSMISSION SERVICE REQUIRED	<ul style="list-style-type: none"> <li>There is a fault in the A/T.</li> </ul>	<ul style="list-style-type: none"> <li>Have your vehicle inspected at an authorised MITSUBISHI MOTORS dealer, immediately. Refer to “When a malfunction occurs in the A/T” on page 6-33.</li> </ul>
 PRESS CLUTCH PEDAL	<ul style="list-style-type: none"> <li>[Vehicles with Easy Select 4WD] The clutch pedal is not depressed during shifting process between “4H” ↔ “4L”.</li> </ul>	Refer to “Drive mode indicator display and 2WD/4WD operation indicator display” on page 6-41.
	<ul style="list-style-type: none"> <li>[Vehicles with Super Select 4WD II] The clutch pedal is not depressed during shifting process between “4HLc” ↔ “4LLc”.</li> </ul>	Refer to “Drive mode indicator display and 2WD/4WD operation indicator display” on page 6-46.



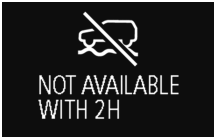

5

Indicator lamp, warning lamp, and information screen display list (multi information display - Type 1)

5

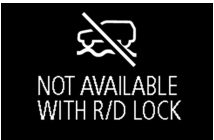
Screen	Cause	Solution (Reference)
	<ul style="list-style-type: none"> <li>● [Vehicles with Super Select 4WD II] The selector lever is shifted from the “N”(NEUTRAL) position to the other position or release the brake pedal during shifting process between “4HLc” ↔ “4LLc”.</li> </ul>	<p>Refer to “Drive mode indicator display and 2WD/4WD operation indicator display” on page 6-46.</p>
	<ul style="list-style-type: none"> <li>● There is a fault in the Easy Select 4WD.</li> </ul>	<ul style="list-style-type: none"> <li>● Have your vehicle inspected at an authorised MITSUBISHI MOTORS dealer as soon as possible. Refer to “Drive mode indicator display and 2WD/4WD operation indicator display” on page 6-41.</li> </ul>
	<ul style="list-style-type: none"> <li>● There is a fault in the Super Select 4WD II.</li> </ul>	<ul style="list-style-type: none"> <li>● Have your vehicle inspected at an authorised MITSUBISHI MOTORS dealer as soon as possible. Refer to “Drive mode indicator display and 2WD/4WD operation indicator display” on page 6-46.</li> </ul>
	<ul style="list-style-type: none"> <li>● The Off Road mode will not be available even if the Off Road mode-selector is pressed because the drive mode-selector of Easy Select 4WD is in “2H”.</li> </ul>	<p>Refer to “Off Road mode-selector operation” on page 6-50.</p>
	<ul style="list-style-type: none"> <li>● The Off Road mode will not be available even if the Off Road mode-selector is pressed because the drive mode-selector of Super Select 4WD II is in “2H” or “4H”.</li> </ul>	<p>Refer to “Off Road mode-selector operation” on page 6-50.</p>





Indicator lamp, warning lamp, and information screen display list (multi information display - Type 1)

Screen	Cause	Solution (Reference)
 TEMPORARILY NOT AVAILABLE	<ul style="list-style-type: none"> <li>The Off Road mode will not be available even if the Off Road mode-selector is pressed because the brake system is abnormally overheated.</li> </ul>	Refer to “Off Road mode indicator display” on page 6-50.
 NOT AVAILABLE WITH R/D LOCK	<ul style="list-style-type: none"> <li>The Off Road mode will not be available even if the Off Road mode-selector is pressed because the rear differential lock is activating.</li> </ul>	Refer to “Off Road mode indicator display” on page 6-50.
 R/D LOCK! R/D LOCK SERVICE REQUIRED	<ul style="list-style-type: none"> <li>There is a fault in the rear differential lock system.</li> </ul>	<ul style="list-style-type: none"> <li>Have your vehicle inspected at an authorised MITSUBISHI MOTORS dealer as soon as possible.</li> </ul> Refer to “The rear differential lock indicator lamp/display” on page 6-52.
 STOP TO OPERATE R/D LOCK	<ul style="list-style-type: none"> <li>You try to be turned on the rear differential lock switch during driving.</li> </ul>	Refer to “Rear differential lock” on page 6-51.
 HDC TEMPORARILY NOT AVAILABLE	<ul style="list-style-type: none"> <li>The Hill Descent Control (HDC) brake control is not available because the brake system is abnormally overheated.</li> </ul>	Refer to “To operate” on page 6-67.
 STOP TO OPERATE HDC	<ul style="list-style-type: none"> <li>The Hill Descent Control (HDC) cannot be set to ON (stand by) because the vehicle speed is 20 km/h or more.</li> </ul>	Refer to “To operate” on page 6-67.





5

Indicator lamp, warning lamp, and information screen display list (multi information display - Type 1)

5

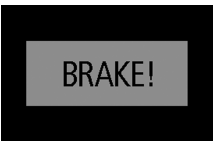
Screen	Cause	Solution (Reference)
	<ul style="list-style-type: none"> <li>The Hill Descent Control (HDC) cannot be set to ON (stand by) because the rear differential lock is activating.</li> </ul>	Refer to “To operate” on page 6-67.
	<ul style="list-style-type: none"> <li>The Hill Descent Control (HDC) is not available because the gearshift lever is placed in the forward gear except the 1st position.</li> </ul>	Refer to “To operate” on page 6-67.
	<ul style="list-style-type: none"> <li>There is a fault in the hill start assist.</li> </ul>	<ul style="list-style-type: none"> <li>Have your vehicle inspected at an authorised MITSUBISHI MOTORS dealer. Refer to “Warning lamp/display” on page 6-66.</li> </ul>
	<ul style="list-style-type: none"> <li>There is a fault in the active stability &amp; traction control (ASTC).</li> </ul>	<ul style="list-style-type: none"> <li>Have your vehicle inspected at an authorised MITSUBISHI MOTORS dealer. Refer to “ASTC warning lamp/display” on page 6-75.</li> </ul>
	<ul style="list-style-type: none"> <li>There is a fault in the ABS.</li> </ul>	<ul style="list-style-type: none"> <li>Avoid sudden braking and high-speed driving, stop the vehicle in a safe place, and take corrective measures. Refer to “ABS warning lamp/display” on page 6-70.</li> </ul>
	<ul style="list-style-type: none"> <li>The braking system temperature is too high.</li> </ul>	<ul style="list-style-type: none"> <li>Immediately stop the vehicle in a safe place. Refer to “ASTC indicator lamp or ASTC OFF indicator lamp” on page 6-74.</li> </ul>

Indicator lamp, warning lamp, and information screen display list (multi information display - Type 1)



Screen	Cause	Solution (Reference)
	<ul style="list-style-type: none"> <li>The Forward Collision Mitigation system (FCM) has detected the danger of collision.</li> </ul>	<ul style="list-style-type: none"> <li>Take appropriate action such as depressing the brake to avoid collision. Refer to “Forward Collision warning function” on page 6-81.</li> </ul>
	<ul style="list-style-type: none"> <li>FCM braking function of the Forward Collision Mitigation system (FCM) has been activated.</li> </ul>	Refer to “FCM braking function” on page 6-82.
	<ul style="list-style-type: none"> <li>There is a fault in the Forward Collision Mitigation system (FCM).</li> </ul>	<ul style="list-style-type: none"> <li>Have your vehicle inspected at an authorised MITSUBISHI MOTORS dealer. Refer to “When a problem is detected” on page 6-86.</li> </ul>
	<ul style="list-style-type: none"> <li>The Forward Collision Mitigation system (FCM) is not available temporarily.</li> </ul>	Refer to “When a problem is detected” on page 6-86.
	<ul style="list-style-type: none"> <li>When the Forward Collision Mitigation system (FCM) is ON, if the drive mode-selector of Easy Select 4WD is set to “4L”, the FCM will be switched to OFF automatically.</li> <li>When the FCM is OFF, the FCM will not be switched to ON even if the FCM and UMS ON/OFF switch is pressed because the drive mode-selector of Easy Select 4WD is in “4L”.</li> </ul>	Refer to “FCM and UMS ON/OFF switch” on page 6-85.

5









Indicator lamp, warning lamp, and information screen display list (multi information display - Type 1)

5

Screen	Cause	Solution (Reference)
 <p>FCM NOT AVAILABLE WITH 4LLc</p>	<ul style="list-style-type: none"> <li>● When the Forward Collision Mitigation system (FCM) is ON, if the drive mode-selector of Super Select 4WD II is set to “4LLc”, the FCM will be switched to OFF automatically.</li> <li>● When the FCM is OFF, the FCM will not be switched to ON even if the FCM and UMS ON/OFF switch is pressed because the drive mode-selector of Super Select 4WD II is in “4LLc”.</li> </ul>	<p>Refer to “FCM and UMS ON/OFF switch” on page 6-85.</p>
 <p>FCM NOT AVAILABLE WITH R/D LOCK</p>	<ul style="list-style-type: none"> <li>● When the Forward Collision Mitigation system (FCM) is ON, if the rear differential lock switch is set to ON, the FCM will be switched to OFF automatically.</li> <li>● When the FCM is OFF, even if the FCM and UMS ON/OFF switch is pressed, the FCM will not be switched to ON because the rear differential lock switch is ON.</li> </ul>	<p>Refer to “FCM and UMS ON/OFF switch” on page 6-85.</p>
 <p>FCM NOT AVAILABLE WITH HDC</p>	<ul style="list-style-type: none"> <li>● When the Forward Collision Mitigation system (FCM) is ON, if the Hill Descent Control (HDC) is set to ON, the FCM will be switched to OFF automatically.</li> <li>● When the FCM is OFF, even if the FCM and UMS ON/OFF switch is pressed, the FCM will not be switched to ON because the Hill Descent Control (HDC) operates.</li> </ul>	<p>Refer to “FCM and UMS ON/OFF switch” on page 6-85.</p>



Indicator lamp, warning lamp, and information screen display list (multi information display - Type 1)

Screen	Cause	Solution (Reference)
  	<ul style="list-style-type: none"> <li>The Ultrasonic misacceleration Mitigation System (UMS) sensor is temporarily not available for some reason such as the environmental condition or increase of the sensor temperature.</li> </ul>	<ul style="list-style-type: none"> <li>When the warning display does not disappear after waiting for a while, contact an authorised MITSUBISHI MOTORS dealer. Refer to “When the sensor is temporarily not available” on page 6-94.</li> </ul>
  	<ul style="list-style-type: none"> <li>The Ultrasonic misacceleration Mitigation System (UMS) does not operate normally because there are some malfunctions in the sensor or the system.</li> </ul>	<ul style="list-style-type: none"> <li>Immediately have your vehicle inspected at an authorised MITSUBISHI MOTORS dealer. Refer to “When there is a malfunction in the system or the sensor” on page 6-94.</li> </ul>

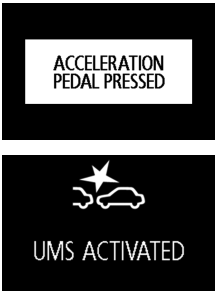

5

Indicator lamp, warning lamp, and information screen display list (multi information display - Type 1)

5

Screen	Cause	Solution (Reference)
	<ul style="list-style-type: none"> <li>● The Ultrasonic misacceleration Mitigation System (UMS) is activated.</li> </ul>	<p>Refer to “Ultrasonic misacceleration Mitigation System (UMS)” on page 6-90.</p>
	<ul style="list-style-type: none"> <li>● When the Ultrasonic misacceleration Mitigation System (UMS) is ON, if the drive mode-selector of Super Select 4WD II is set to “4LLc”, the Ultrasonic misacceleration Mitigation System (UMS) will be switched to OFF automatically.</li> <li>● When the Ultrasonic misacceleration Mitigation System (UMS) is OFF, even if the FCM and UMS ON/OFF switch is pressed, the Ultrasonic misacceleration Mitigation System (UMS) will not be switched to ON because the drive mode-selector of Super Select 4WD II is in “4LLc”.</li> </ul>	<p>Refer to “When the UMS is not available” on page 6-95.</p>





Indicator lamp, warning lamp, and information screen display list (multi information display - Type 1)

Screen	Cause	Solution (Reference)
	<ul style="list-style-type: none"> <li>● When the Ultrasonic misacceleration Mitigation System (UMS) is ON, if the rear differential lock switch is set to ON, the Ultrasonic misacceleration Mitigation System (UMS) will be switched to OFF automatically.</li> <li>● When the Ultrasonic misacceleration Mitigation System (UMS) is OFF, even if the FCM and UMS ON/OFF switch is pressed, the Ultrasonic misacceleration Mitigation System (UMS) will not be switched to ON because the rear differential lock switch is ON.</li> </ul>	<p>Refer to “When the UMS is not available” on page 6-95.</p>
	<ul style="list-style-type: none"> <li>● When the Ultrasonic misacceleration Mitigation System (UMS) is ON, if the Hill Descent Control (HDC) is set to ON, the Ultrasonic misacceleration Mitigation System (UMS) will be switched to OFF automatically.</li> <li>● When the Ultrasonic misacceleration Mitigation System (UMS) is OFF, even if the FCM and UMS ON/OFF switch is pressed, the Ultrasonic misacceleration Mitigation System (UMS) will not be switched to ON because the Hill Descent Control (HDC) operates.</li> </ul>	<p>Refer to “When the UMS is not available” on page 6-95.</p>





5

Indicator lamp, warning lamp, and information screen display list (multi information display - Type 1)

5

Screen	Cause	Solution (Reference)
 <p>BSW TEMPORARILY NOT AVAILABLE</p>	<ul style="list-style-type: none"> <li>The Blind Spot Warning (BSW) sensor is temporarily not available for some reason such as the environmental condition or increase of the sensor temperature.</li> </ul>	<ul style="list-style-type: none"> <li>When the warning display does not disappear after waiting for a while, contact an authorised MITSUBISHI MOTORS dealer. Refer to “When the sensor is temporarily not available” on page 6-99.</li> </ul>
 <p>BSW SERVICE REQUIRED</p>	<ul style="list-style-type: none"> <li>The Blind Spot Warning (BSW) does not operate normally because there are some malfunctions in the sensor or the system.</li> </ul>	<ul style="list-style-type: none"> <li>Have your vehicle inspected at an authorised MITSUBISHI MOTORS dealer as soon as possible. Refer to “When there is a malfunction in the system or the sensor” on page 6-98.</li> </ul>
 <p>BSW RADAR BLOCKED</p>	<ul style="list-style-type: none"> <li>Foreign objects, such as dirt, snow or ice, adhere to the bumper surface around the sensor.</li> </ul>	<ul style="list-style-type: none"> <li>Remove a foreign object on the bumper surface around the sensor. When the warning display does not disappear after having cleaned the bumper surface around the sensor, contact an authorised MITSUBISHI MOTORS dealer. Refer to “Blind Spot Warning (BSW): When there is a foreign objects on the sensor” on page 6-99.</li> </ul>
 <p>ATTENTION! REAR CROSS TRAFFIC</p>	<ul style="list-style-type: none"> <li>The Rear Cross Traffic Alert (RCTA) is detected vehicle approaching your vehicle.</li> </ul>	<ul style="list-style-type: none"> <li>Pay special attention to the rear of your vehicle. Refer to “Rear Cross Traffic Alert (RCTA)” on page 6-99.</li> </ul>

Indicator lamp, warning lamp, and information screen display list (multi information display - Type 1)

Screen	Cause	Solution (Reference)
 ENGINE OVERHEATING STOP SAFELY	<ul style="list-style-type: none"> <li>The engine is overheated.</li> </ul>	<ul style="list-style-type: none"> <li>Stop the vehicle in a safe place and take corrective measures.</li> <li>Refer to “Engine overheating” on page 8-4.</li> </ul>
 DRIVER ASSISTANCE CAMERA SERVICE REQUIRED	<ul style="list-style-type: none"> <li>There is a fault in the sensor.</li> </ul>	<ul style="list-style-type: none"> <li>We recommend you to consult an authorised MITSUBISHI MOTORS dealer.</li> <li>Refer to “Forward Collision Mitigation system (FCM): When a problem is detected” on page 6-86.</li> <li>Refer to “Automatic High Beam (AHB): System problem warning” on page 5-58.</li> </ul>
 DRIVER ASSISTANCE CAMERA TEMPORARILY NOT AVAILABLE	<ul style="list-style-type: none"> <li>The Forward Collision Mitigation system (FCM) and Automatic High Beam (AHB) is temporarily unavailable due to the high or low temperature of the sensor.</li> </ul>	<ul style="list-style-type: none"> <li>After the temperature of the sensor has been in range, the system will automatically return to operation.</li> <li>Refer to “Forward Collision Mitigation system (FCM): When a problem is detected” on page 6-86.</li> <li>Refer to “Automatic High Beam (AHB): System problem warning” on page 5-58.</li> </ul>
 DRIVER ASSISTANCE CAMERA BLOCKED	<ul style="list-style-type: none"> <li>The sensor is temporarily unavailable due to conditions such as the adhesion of contaminants to the sensor or windscreen.</li> <li>This is not a malfunction.</li> </ul>	<ul style="list-style-type: none"> <li>Refer to “Forward Collision Mitigation system (FCM): When a problem is detected” on page 6-86.</li> <li>Refer to “Automatic High Beam (AHB): System problem warning” on page 5-58.</li> </ul>
 AHB SERVICE REQUIRED	<ul style="list-style-type: none"> <li>There is a fault in the Automatic High Beam (AHB).</li> </ul>	<ul style="list-style-type: none"> <li>We recommend you to consult an authorised MITSUBISHI MOTORS dealer.</li> <li>Refer to “Automatic High Beam (AHB): System problem warning” on page 5-58.</li> </ul>



5

Indicator lamp, warning lamp, and information screen display list (multi information display - Type 1)

Screen	Cause	Solution (Reference)
	<ul style="list-style-type: none"> <li>More than specified limit water has accumulated in the fuel filter.</li> </ul>	<ul style="list-style-type: none"> <li>Refer to “Removal of water from the fuel filter” on page 8-5.</li> </ul>

**5** Other interrupt displays



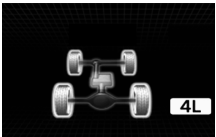

E00524202530

Screen	System operation status	Reference
	<ul style="list-style-type: none"> <li>When starting the engine, you pressed the engine switch without depressing the clutch pedal (M/T).</li> </ul>	<ul style="list-style-type: none"> <li>Place the gearshift lever in the “N” (Neutral) position, fully depress the clutch pedal, depress the brake pedal with the right foot. Then, press the engine switch. Refer to “Starting the engine” on page 6-19.</li> </ul>
	<ul style="list-style-type: none"> <li>When starting the engine, the selector lever is in a position other than the “P” (PARK) or the “N” (NEUTRAL) position, or you pressed the engine switch without depressing the brake pedal (A/T).</li> </ul>	<ul style="list-style-type: none"> <li>Place the selector lever in the “P” (PARK) position, depress the brake pedal with the right foot. Then, press the engine switch. Refer to “Starting the engine” on page 6-19.</li> </ul>

The operation status of each system is displayed on the information screen. Refer to the appropriate page for the system for further details.

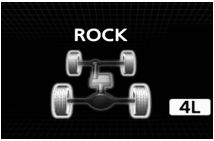
Screen	System operation status	Reference
	<ul style="list-style-type: none"> <li>When the drive mode is shifted by operating the drive mode-selector.</li> </ul>	<ul style="list-style-type: none"> <li>Refer to “Easy Select 4WD” on page 6-35.</li> <li>Refer to “Super Select 4WD II ” on page 6-42.</li> </ul>

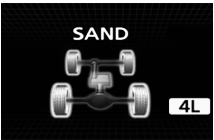
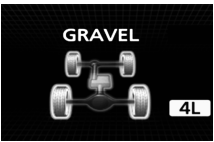
Indicator lamp, warning lamp, and information screen display list (multi information display - Type 1)





Screen	System operation status	Reference
	<ul style="list-style-type: none"> <li>When "ROCK" mode of Off Road mode is selected.</li> </ul>	Refer to "Control mode" on page 6-49.
	<ul style="list-style-type: none"> <li>When "MUD/SNOW" mode of Off Road mode is selected.</li> </ul>	Refer to "Control mode" on page 6-49.
	<ul style="list-style-type: none"> <li>When "SAND" mode of Off Road mode is selected.</li> </ul>	Refer to "Control mode" on page 6-49.
	<ul style="list-style-type: none"> <li>When "GRAVEL" mode of Off Road mode is selected.</li> </ul>	Refer to "Control mode" on page 6-49.
	<ul style="list-style-type: none"> <li>When the Forward Collision Mitigation system (FCM) is deactivated.</li> </ul>	Refer to "FCM and UMS ON/OFF switch" on page 6-85.
	<ul style="list-style-type: none"> <li>When the Ultrasonic misacceleration Mitigation System (UMS) is deactivated.</li> </ul>	

5



Indicator lamp, warning lamp, and information screen display list (multi information display - Type 1)

5

Screen	System operation status	Reference
  	<ul style="list-style-type: none"> <li>When the Forward Collision Mitigation system (FCM) is activated or the timing of an alarm is changed.</li> </ul>	Refer to “FCM and UMS ON/OFF switch” on page 6-85.
	<ul style="list-style-type: none"> <li>When the reversing sensor system detects an obstruction.</li> </ul>	Refer to “To operate” on page 6-103.
	<ul style="list-style-type: none"> <li>When the sensor system detects an obstruction.</li> </ul>	Refer to “To operate” on page 6-107.

This informs you that a periodic inspection is due.

Screen	Solution
	We recommend you to have it checked. Refer to “Service reminder” for further details on page 5-8.

Indicator lamp, warning lamp, and information screen display list (multi information display - Type 1)

The setting for rest interval can be changed.

Screen	Solution
	<p>Stop the vehicle in a safe place, turn off the engine, and take a rest.                      Use this display as rough guide for taking rests during a long drive.                      The interval from the start of your trip until this message is displayed can be set.                      Refer to “Changing the time until “REST REMINDER” is displayed” on page 5-16.                      The display and buzzer alert the driver when the set time is reached. If you continue to drive without having a rest, the buzzer sounds approximately every 5 minutes to encourage you to take a rest.</p> <ul style="list-style-type: none"> <li>● In the following cases, the time driven is reset and the display returns to the previous display screen. After this, when the set time is reached again, the buzzer and display encourage you to take a rest.                             <ul style="list-style-type: none"> <li>• The buzzer sounds 3 times.</li> <li>• Turn the ignition switch to the “LOCK” position or put the operation mode in OFF.</li> <li>• The multi information display switch is held for approximately 2 seconds or more.</li> </ul> </li> </ul>

5

## Indicator and warning lamps (multi information display - Type 2)

E00501504527

5

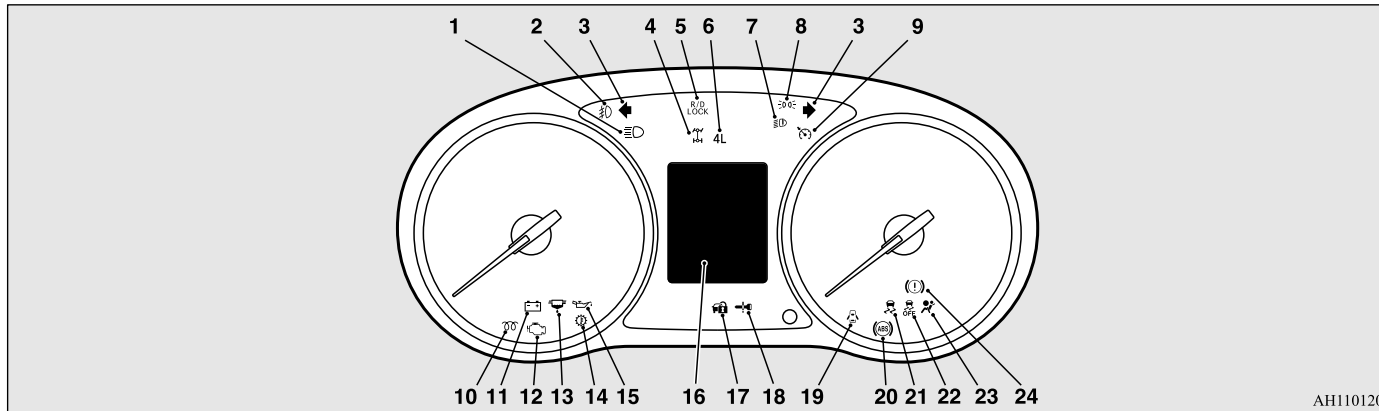

AH1101206

- |  |   |   |
|--|---|---|
| <p>1- High-beam indicator lamp → P.5-49</p> <p>2- Front fog lamp indicator lamp* → P.5-49</p> <p>3- Turn-signal indicator lamps/Hazard warning indicator lamps → P.5-49</p> <p>4- 2WD/4WD operation indicator lamp* → P.6-36, 6-39</p> <p>5- Rear differential lock indicator lamp* → P.6-52</p> <p>6- Low-range indicator lamp* → P.6-36</p> <p>7- LED headlamp warning lamp* → P.5-52</p> <p>8- Position lamp indicator lamp* → P.5-49</p> | <p>9- Cruise control indicator lamp* → P.6-77</p> <p>10- Diesel preheat indicator lamp → P.5-49</p> <p>11- Charge warning lamp → P.5-51</p> <p>12- Check engine warning lamp → P.5-51</p> <p>13- Fuel filter indicator lamp → P.5-50</p> <p>14- A/T fluid temperature warning lamp (vehicles with A/T) → P.6-33</p> <p>15- Oil pressure warning lamp → P.5-51</p> <p>16- Multi information display → P.5-18</p> | <p>17- For details, refer to “Electronic immobilizer (Anti-theft starting system)” on page 3-3. (if so equipped)<br/>For details, refer to “Steering wheel lock” on page 6-16. (if so equipped)</p> <p>18- For details, refer to “Warning activation” on page 3-12. (if so equipped)<br/>For details, refer to “Steering wheel lock” on page 6-16. (if so equipped)</p> <p>19- Door-ajar warning lamp → P.5-52</p> <p>20- Anti-lock brake system (ABS) warning lamp → P.6-70</p> <p>21- Active Stability &amp; Traction Control (ASTC) indicator lamp* → P.6-74</p> |
|--|---|---|

- 22- Active Stability & Traction Control (ASTC) OFF indicator lamp\* → P.6-74
- 23- Supplemental restraint system (SRS) warning lamp\* → P.4-25
- 24- Brake warning lamp → P.5-50

## Indicator lamps

E00501601253

## Turn-signal indicator lamps/Hazard warning indicator lamps

E00501701687

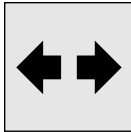

These indicator lamps blink in the following situations.

- When the turn-signal lever is moved to activate a turn-signal lamp.

Refer to “Turn-signal lever” on page 5-60.

- When the hazard warning flasher switch is pressed to activate the hazard warning lamps.

Refer to “Hazard warning flasher switch” on page 5-60.

- When the hazard warning lamps automatically activate due to sudden braking while driving (vehicles equipped with the emergency stop signal system).

Refer to “Emergency stop signal system” on page 6-69.

## High-beam indicator lamp

E00501801327

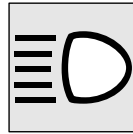

This indicator lamp illuminates when the high beam is used.

## Front fog lamp indicator lamp\*

E00501901663



This lamp illuminates while the front fog lamps are on.

## Position lamp indicator lamp\*

E00508901330

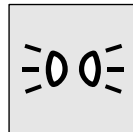

This indicator lamp illuminates while the position lamps are on.

## Diesel preheat indicator lamp

E00502301475

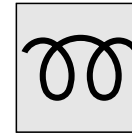

This indicates the glow plug preheat condition.

[Except for vehicles equipped with the keyless operation system]

When the ignition switch is turned to the “ON” position, the lamp illuminates. As the glow plug becomes hot, the lamp goes out and the engine can be started.

[For vehicles equipped with the keyless operation system]

When the operation mode is put in ON, the lamp illuminates and preheating of the glow plug starts automatically. As the glow plug becomes hot, the lamp goes out and the engine starts.

## NOTE

- If the engine is cold, the diesel preheat indicator lamp is on for a longer time.
- [Except for vehicles equipped with the keyless operation system]  
When the engine has not been started within about 5 seconds after the diesel preheat indicator lamp went out, return the ignition switch to the “LOCK” position. Then, turn the ignition switch to the “ON” position to preheat the engine again.

## Warning lamps

### NOTE

- When the engine is warm, the diesel preheat indicator lamp does not come on even if the ignition switch is placed in the “ON” position or the operation mode is in ON.

5

### Fuel filter indicator lamp (Vehicles equipped with the multi information display - Type 2)

E00509901425



This indicator lamp illuminates when the ignition switch is turned to the “ON” position or the operation mode is put in ON, and goes off after the engine has started. If it lights up while the engine is running, it indicates that water has accumulated inside the fuel filter; if this happens, take action as follows.

Remove the water from the fuel filter. Refer to “Removal of water from the fuel filter” on page 8-5.

When the lamp goes out, you can resume driving. If it either does not go out or comes on from time to time, have the vehicle inspected at an authorised MITSUBISHI MOTORS dealer.

## Warning lamps

E00502400147

### Brake warning lamp

E00502504276



This lamp illuminates when the ignition switch is turned to the “ON” position or the operation mode is put in ON, and goes off after a few seconds.

Always make sure that the lamp goes off before driving.

With the ignition switch or the operation mode in ON, the brake warning lamp illuminates under the following conditions:

- When the parking brake has been applied.
- When the brake fluid level in the reservoir falls to a low level.
- When the brake force distribution function is not operating correctly.

With the ignition switch or the operation mode in ON, a buzzer sounds under the following condition:

- The vehicle speed exceeds 8 km/h with the parking brake applied.

## CAUTION

- In the situations listed below, brake performance may be compromised or the vehicle may become unstable if brakes are applied suddenly; consequently, avoid driving at high speeds or applying the brakes suddenly. Furthermore, immediately the vehicle should be brought to a stop in a safe location and your nearest authorised MITSUBISHI MOTORS dealer should be contacted.
  - The brake warning lamp does not illuminate when the parking brake is applied or does not turn off when the parking brake is released.
  - The brake warning lamp and the ABS warning lamp illuminate at the same time. For details, refer to “ABS warning lamp/display” on page 6-70.
  - The brake warning lamp remains illuminated while driving.
- The vehicle should be brought to a halt in the following manner when brake performance has deteriorated.
  - Depress the brake pedal harder than usual. Even if the brake pedal moves down to the very end of its possible stroke, keep it pressed down hard.
  - Should the brakes fail, use engine braking to reduce your speed and carefully pull the parking brake lever.
    - Depress the brake pedal to operate the stop lamp to alert the vehicles behind you.

**Check engine warning lamp**

E00502603238

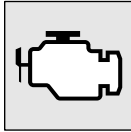

This lamp is a part of an onboard diagnostic system which monitors the emissions, engine control system or A/T control system.

If a problem is detected in one of these systems, this lamp illuminates or flashes.

Although your vehicle will usually be drivable and not need towing, we recommend you to have the system checked as soon as possible.

This lamp will also illuminate when the ignition switch is turned "ON" or the operation mode is put in ON, and goes off after the engine has started. If it does not go off after the engine has started, we recommend you to have the vehicle checked.

**CAUTION**

- Prolonged driving with this lamp on may cause further damage to the emission control system. It could also affect fuel economy and drivability.
- If the lamp does not illuminate when the ignition switch is turned to the "ON" position or the operation mode is put in ON, we recommend you to have the system checked.

**CAUTION**

- If the lamp illuminates while the engine is running, avoid driving at high speeds and have the system inspected by an authorised MITSUBISHI MOTORS dealer as soon as possible. Accelerator pedal and brake pedal response may be negatively influenced under these conditions.

**NOTE**

- The engine electronic control module accommodating the onboard diagnostic system has various fault data (especially about the exhaust emission) stored.

This data will be erased if a battery cable is disconnected which will make a rapid diagnosis difficult. Do not disconnect a battery cable when the check engine warning lamp is ON.

**Charge warning lamp**

E00502702304

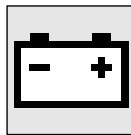

started.

This lamp illuminates when the ignition switch is turned to the "ON" position or the operation mode is put in ON, and goes off after the engine has

**CAUTION**

- If it illuminates while the engine is running, there is a problem in the charging system. Immediately park your vehicle in a safe place and we recommend you to have it checked.

**Oil pressure warning lamp (Vehicles equipped with the multi information display - Type 2)**

E00502801904

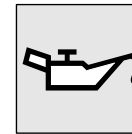

This lamp illuminates when the ignition switch is turned to the "ON" position or the operation mode is put in ON, and the lamp goes off after the engine has started. If it illuminates while the engine is running, the oil pressure is too low. If the warning lamp illuminates while the engine is running, turn the engine off and contact your nearest authorised MITSUBISHI MOTORS dealer for inspection.

**CAUTION**

- If this lamp illuminates when the engine oil level is not low, contact your nearest authorised MITSUBISHI MOTORS dealer for inspection.

Information screen display (Vehicles equipped with the multi information display - Type 1)

5

**CAUTION**

- This warning lamp does not indicate the amount of oil in the crankcase. This must be determined by checking the oil level on the dipstick, while the engine is switched off.
- If you continue driving with low engine oil level or with this warning lamp illuminated, engine seizure may occur.

**NOTE**

- The oil pressure warning lamp should not be treated as an indication of the engine's oil level. The oil level must be checked using the dipstick.

**Door-ajar warning lamp**

E00503302059



This lamp illuminates when a door is either open or not completely closed.

If the vehicle speed reaches approximately 8 km/h with a door open or incompletely closed, a buzzer sounds 4 times as a warning.

**CAUTION**

- Before moving your vehicle, check that the warning lamp is OFF.

**LED headlamp warning lamp\***

E00569000078



This warning lamp in the instrument cluster will illuminate when there is a fault in the LED headlamps.

**CAUTION**

- If the warning lamp illuminates, there may be a fault on the unit. Have the vehicle checked at an authorised MITSUBISHI MOTORS dealer.

**Information screen display  
(Vehicles equipped with the  
multi information display -  
Type 1)**

E00524601292

**Brake warning display**

E00524701639



This warning is displayed if you drive with the parking brake still applied. The warning lamp in the instrument cluster also illuminates when the parking brake is applied.

If this warning is displayed, lower the parking brake lever fully.

**CAUTION**

- If a vehicle is driven without releasing the parking brake, the brake will be overheated, resulting in ineffective braking and possible brake failure.



When the ignition switch or the operation mode is put in ON, if the brake fluid is low, this warning is displayed.

The warning lamp in the instrument cluster also illuminates.

**CAUTION**

- If this warning stays illuminated and does not go out while driving, there is a danger of ineffective braking. If this happens, immediately park your vehicle in a safe place and we recommend you to have it checked.

**CAUTION**

- If the brake warning display is displayed and the brake warning lamp and the ABS warning lamp are illuminated at the same time, the braking force distribution function will not operate, so the vehicle may be destabilised during sudden braking. Avoid sudden braking and high-speed driving, stop the vehicle in a safe place, and we recommend you to have it checked.
  - The vehicle should be brought to a halt in the following manner when brake performance has deteriorated.
    - Depress the brake pedal harder than usual. Even if the brake pedal moves down to the very end of its possible stroke, keep it pressed down hard.
    - Should the brakes fail, use engine braking to reduce your speed and carefully pull the parking brake lever.
- Depress the brake pedal to operate the stop lamp to alert the vehicles behind you.

**Charge warning display**

E00524801311



If there is a fault with the charging system, the warning display is displayed on the infor-

mation screen in the multi information display. The warning lamp in the instrument cluster also illuminates.

**CAUTION**

- If the warning is displayed while the engine is running, immediately park your vehicle in a safe place and we recommend you to have it checked.

**Oil pressure warning display**

E00524901396



If the engine oil pressure drops while the engine is running, the warning display is displayed on the information screen in the multi information display.

**CAUTION**

- If the vehicle is driven while the engine oil is low, or the oil level is normal but the warning is displayed, the engine may burn out and be damaged.

**CAUTION**

- If the warning is displayed while the engine is running, immediately park your vehicle in a safe place and check the engine oil level. Refer to “Maintenance: Engine oil” on page 10-5.
- If the warning is displayed while the engine oil level is normal, have it inspected.

5

**Combination headlamps and dipper switch**

E00506004716

**Headlamps**

**NOTE**

- Do not leave the lamps on for a long time while the engine is stationary (not running). A run-down battery could result.
- When it rains, or when the vehicle has been washed, the inside of the lens sometimes becomes foggy, but this does not indicate a functional problem. When the lamp is switched on, the heat will remove the fog. However, if water gathers inside the lamp, we recommend you to have checked.



## Combination headlamps and dipper switch

### Type 1

Rotate the switch to turn on the lamps.

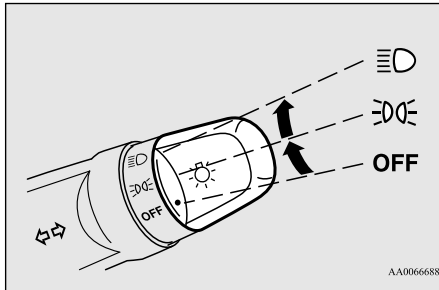

OFF	All lamps off
	Position, tail, licence plate and instrument panel lamps on
	Headlamps and other lamps go on

### Type 2

Rotate the switch to turn on the lamps.

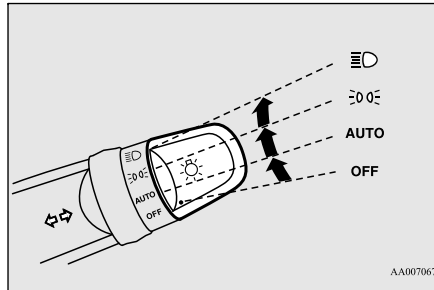

OFF	All lamps off
AUTO	With the ignition switch or the operation mode is in ON, headlamps, position, tail, licence plate and instrument panel lamps turn on and off automatically in accordance with outside light level. All lamps turn off automatically when the ignition switch is turned to "OFF" position or the operation mode is put in OFF.
	Position, tail, licence plate and instrument panel lamps on
	Headlamps and other lamps go on

### NOTE

- The sensitivity of the automatic on/off control can be adjusted. For further information, contact an authorised MITSUBISHI MOTORS dealer.
- If the front fog lamps (if so equipped) turn on when they are supposed to with the switch in the "AUTO" position, the lamps turn off automatically with the ignition switch or operation mode off.
- When the headlamps are turned off by the automatic on/off control with the ignition switch is turned to the "ON" position or the operation mode in ON, the front fog lamps (if so equipped) also go off. When the headlamps are subsequently turned back on by the automatic on/off control, the front fog lamps also come on.
- Do not cover the sensor (A) for the automatic on/off control by affixing a sticker or label to the windscreen.

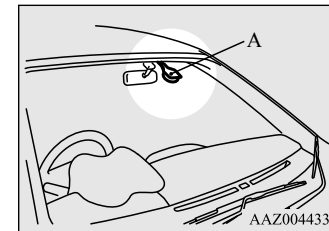

- If the lamps do not turn on or off with the switch in the "AUTO" position, manually operate the switch and we recommend you to have your vehicle checked.

5

**Lamps (headlamps, fog lamp, etc.) auto-cutout function**

E00532701827

- If the following operation is performed while the lamp switch is in the “☰D” position, the lamps are automatically turned off when the driver’s door is opened.  
[Except for vehicles equipped with the keyless operation system]  
The ignition switch is turned to the “LOCK” or “ACC” position, or the key is removed from the ignition switch.  
[For vehicles equipped with the keyless operation system]  
The operation mode is put in OFF or ACC.
- If the following operation is performed while the lamp switch is in the “☰D” position, the lamps are automatically turned off if the driver’s door then remains closed for approximately three minutes.  
[Except for vehicles equipped with the keyless operation system]  
The ignition switch is turned to the “LOCK” or “ACC” position, or the key is removed from the ignition switch.  
[For vehicles equipped with the keyless operation system]  
The operation mode is put in OFF or ACC.

**NOTE**

- The lamp auto-cutout function can also be disabled.  
For further information, we recommend you to consult an authorised MITSUBISHI MOTORS dealer.

**Lamp monitor buzzer**

E00506101804

If the following operation is performed, a buzzer will sound to remind the driver to turn off the lamps.  
[Except for vehicles equipped with the keyless operation system]  
If the driver’s door is opened when the key is in the “LOCK” or “ACC” position or removed from the ignition switch while the lamps are on.  
[For vehicles equipped with the keyless operation system]  
If the driver’s door is opened when the operation mode is in ACC or OFF while the lamps are on.  
[For vehicles equipped with the keyless operation system]  
In both cases, the buzzer will automatically stop if the auto-cutoff function is activated, the lamp switch is turned off, or the door is closed.

**Daytime running lamp\***

E00530601545

The daytime running lamps comes on when the engine is running and the lamp switch is in the “OFF” or “AUTO” position and the tail lamps are off.

**Dipper (High/Low beam change)**

E00506201762

When the lamp switch is in the “☰D” position, the beam changes from high to low (or low to high) each time the lever is pulled fully (1). While the high beam is on, the high beam indicator lamp in the instrument cluster will also illuminate.

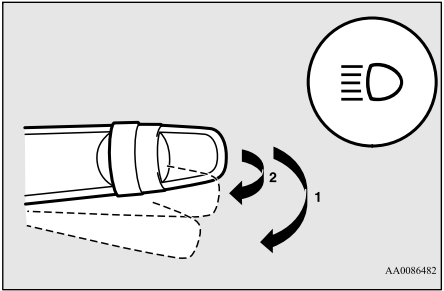

## Combination headlamps and dipper switch

### Headlamp flasher

E00506300199

The high beams flash when the lever is pulled slightly (2), and will go off when it is released.

When the high beam is on, the high beam indicator lamp in the instrument cluster will illuminate.

5

#### NOTE

- The high beams can also flash when the lamp switch is OFF.
- If you turn the lamps off with the headlamps set to highbeam, the headlamps are automatically returned to their low-beam setting when the lamp switch is next turned to the “D” position.

### Automatic High Beam (AHB)\*

E00538200250

The Automatic High Beam (AHB) switches the headlamp beams (high/low) when the sensor (A) senses a illuminant such as lights of a vehicle in front or oncoming vehicle or a street lamp.

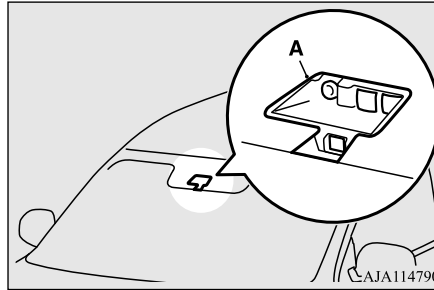

#### WARNING

- **The headlamp beams (high/low) may not be switched automatically under certain circumstances. Do not overestimate the system. It is the responsibility of the driver to switch the headlamp beams (high/low) manually to suit each driving condition.**  
Refer to “Dipper (High/Low beam change)” on page 5-55.

### How to use the AHB

E00551500263

1. Rotate the lamp switch to “D” position or “AUTO” position when the engine is running.

2. Press the AHB switch.

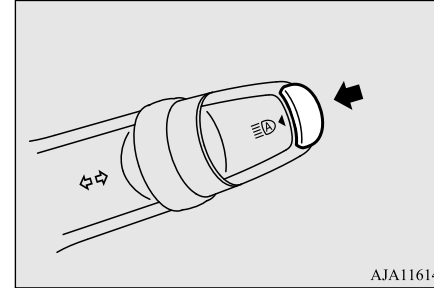

The AHB is activated and the indicator will illuminate.

If the AHB switch is pressed again, the AHB will be deactivated and AHB indicator will go off.

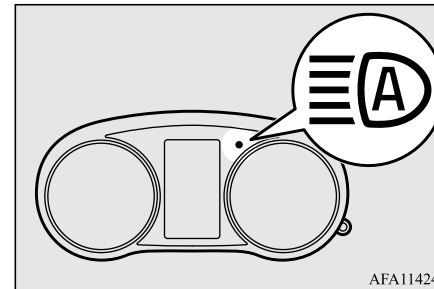

#### NOTE

- If the headlamps are on when the lamp switch is in the “AUTO” position, the AHB works.

 **NOTE**

- You can switch the headlamp beams (high/low) manually by operating the lever even if the AHB is working. Refer to “Dipper (High/Low beam change)” on page 5-55. If the lever is operated manually, the AHB indicator will go off and the AHB will be deactivated. Refer to “Manual switching” on page 5-57.
- The AHB is not deactivated when you pull the lever slightly (operation of the headlamp flasher).

■ **Manual switching**

**Switching to low beam**

1. Pull the turn-signal lever towards you.
2. The AHB indicator will go off.
3. The AHB switch is pressed again, the AHB will be activated.

**Switching to high beam**

1. Pull the turn-signal lever towards you.
2. The AHB indicator will go off and the high beam indicator illuminates.
3. The AHB switch is pressed again, the AHB will be activated.

**Automatic switching conditions**

E00551600105

The high beam headlamps illuminate when all of the following conditions are met:

- Your vehicle speed exceeds approximately 40 km/h.
- It is dark ahead of your vehicle.
- There are no vehicles in front or oncoming vehicles, or none of their exterior lamps are illuminating.

The low beam headlamps illuminate when any of the following conditions occur:

- Your vehicle speed does not exceed approximately 30 km/h.
- It is bright ahead of your vehicle.
- An exterior lamp of a vehicle in front or oncoming vehicle is illuminating.

 **NOTE**

- The headlamps may not be switched from high beam to low beam under the following circumstances.
  - A vehicle in front or oncoming vehicle is hindered by any object such as continuous bends, elevated median/island, traffic signs, roadside trees.
  - Your vehicle passes an oncoming vehicle suddenly on a bend with poor visibility.

 **NOTE**

- Another vehicle crosses ahead of your vehicle.
- The headlamps may remain at low beam (or be switched from high beam to low beam) when a reflective object (e.g. street lamp, traffic signal, noticeboard and signboard) reflects light.
- Any of the following factors may influence the headlamp beam switching timing:
  - How brightly the exterior lamps of a vehicle in front or oncoming vehicle illuminate.
  - Movement or direction of a vehicle in front or oncoming vehicle.
  - Only right or left exterior lamp of a vehicle in front or oncoming vehicle is illuminating.
  - A vehicle in front or oncoming vehicle is a motorcycle.
  - Road conditions (gradient, bends and road surface).
  - The number of occupants and luggage load.
- The AHB recognises environmental conditions by sensing a light source ahead of your vehicle. Therefore, you may feel like something is not quite right when the headlamp beams are switched automatically.
- The system may not detect a light vehicle such as a bicycle.
- The system may not detect an ambient brightness precisely. This causes the traffic to be dazzled by high beam or the low beam to be maintained. In such cases, you should switch the headlamp beams manually.

## Combination headlamps and dipper switch

5

### NOTE

- In bad weather (heavy rain, fog, snow or sandstorm).
- The windscreen is dirty or fogged up.
- The windscreen is cracked or broken.
- The sensor is deformed or dirty.
- A light, which is similar to the headlamps or tail lamps, is shining around your vehicle.
- A vehicle in front or oncoming vehicle is driven without lights, the exterior lamps are dirty or discoloured, or the direction of the headlamp beams is adjusted improperly.
- It becomes dark and bright suddenly and continuously around your vehicle.
- Your vehicle is driven on uneven surfaces.
- Your vehicle is driven on a winding road.
- A reflective object such as a noticeboard or a mirror reflects a light ahead of your vehicle.
- When lamps of the vehicle in front or headlamps of an oncoming vehicle blend into the other lamps.
- The rear end of a vehicle in front (such as a container truck) reflect a strong light.
- Your vehicle's headlamp is broken or dirty.
- Your vehicle is inclined due to a flat tyre or towing.
- The warning display appears.  
(Refer to "System problem warning" on page 5-58.)
- Observe the precautions below to maintain good usage conditions:

### NOTE

- Do not attempt to disassemble the sensor.
- Do not affix a sticker or label on the windscreen near the sensor.
- Avoid overload.
- Do not modify your vehicle.
- When the windscreen is replaced, use the MITSUBISHI MOTORS GENUINE parts.

### System problem warning

E00551700180

If a problem occurs with the system, the following warning display will appear to the type of the problem.

#### ■ The AHB deactivation due to fault

If a failure is detected in the system, the following warning display will appear and the AHB will automatically be turned off. If the warning display remains even after the ignition switch is turned to the "LOCK" position or the operation mode is put in OFF and then turned back to ON, please contact an authorised MITSUBISHI MOTORS dealer.

[When the AHB is malfunctioning]



[When the sensor is malfunctioning]



### NOTE

- If the sensor or its surrounding area becomes extremely high temperature when parking the vehicle under a blazing sun, the "AHB SERVICE REQUIRED" warning display may appear. If the warning display remains even after the temperature of the sensor or its surrounding area has been in range, please contact an authorised MITSUBISHI MOTORS dealer.

#### ■ Sensor is too hot or cold

If the system becomes temporarily unavailable due to the high or low temperature of the sensor, the following warning display will appear.

After the temperature of the sensor has been in range, the system will automatically return to operation.

If the warning display does not disappear after waiting for a while, there is a possibility that the AHB has a malfunction. Contact an authorised MITSUBISHI MOTORS dealer for inspection of the system.

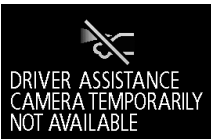

### ■ Windscreen is dirty

If the AHB determines that its performance has been degraded, the warning display will appear.

This can occur when:

- Foreign objects, such as dirt, snow or ice, adhere to the windscreen of the sensor portion.
- In adverse weather conditions, such as rain, snow, sandstorms, etc.
- A front vehicle or an oncoming vehicle is splashing water, snow or dirt.

When the sensor performance returns, the AHB will resume operation.

If the warning display does not disappear after waiting for a while, there is a possibility that the sensor has a malfunction. Contact an authorised MITSUBISHI MOTORS dealer for inspection of the sensor.



## Headlamp levelling switch\*

E00506402093

The angle of the headlamp beam varies depending upon the load carried by the vehicle.

The headlamp levelling switch can be used to adjust the headlamp illumination distance (when the lower beam is illuminated) so that the headlamps' glare does not distract the drivers of approaching vehicles.

Set the switch (referring to the following table) to the appropriate position according to the number of people and the load in the vehicle.

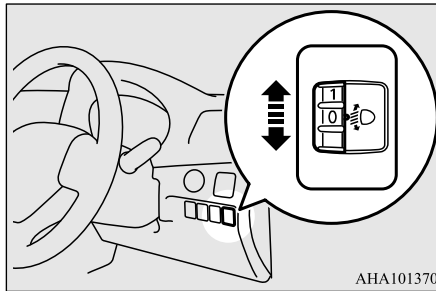

AHA101370

### ⚠ CAUTION

- Always perform adjustments before driving. Do not attempt to adjust while driving, as it could cause an accident.

## Headlamp levelling switch\*

### NOTE

- When adjusting the beam position, first put the dial in the "0" position (the highest beam position).

### Club cab

Vehicle condition		
Switch position	"0"	"3"

●: 1 person

▨: Full luggage loading

Switch position 0- Driver only

Switch position 3- Driver + Full luggage loading

### Double cab

Vehicle condition		
Switch position	"0"	"4"

## Turn-signal lever

- : 1 person
- ▨: Full luggage loading

Switch position 0- Driver only

Switch position 4- Driver + Full luggage loading

5

### Turn-signal lever

E00506502951

The turn-signal lamps flash when the lever is operated (with the ignition switch or the operation mode is in ON). At the same time, the turn-signal indicator flashes.

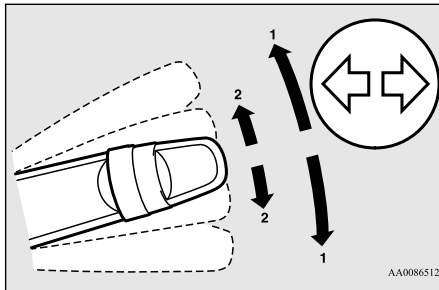

#### 1- Turn-signals

When making a normal turn, use position (1). The lever will return automatically when cornering is completed.

#### 2- Lane-change signals

When moving the lever to (2) slightly to change a lane, the turn-signal lamps and indicator lamp in the instrument cluster will only flash while the lever is operated.

Also, when you move the lever to (2) slightly then release it, the turn-signal lamps and indicator lamp in the instrument cluster will flash three times.

### NOTE

- If the lamp flashes unusually quickly, the bulb in a turn-signal lamp may have burned out. We recommend you to have the vehicle inspected.
- It is possible to activate the following functions:
  - Flashing of the turn-signal lamps when the lever is operated with the ignition switch or the operation mode is in ACC.
  - The turn-signal lamps 3-flash function for lane changes can be deactivated.
  - The time required to operate the lever for the 3-flash function can be adjusted.
  - Changing of the tone of a sounding buzzer as the turn-signal lamps flash.

For further information, we recommend you to consult an authorised MITSUBISHI MOTORS dealer.

### Hazard warning flasher switch

E00506602255

Use the hazard warning flasher switch when the vehicle has to be parked on the road for any emergency.

The hazard warning flashers can always be operated, regardless of the ignition switch position or the operation mode.

Push the switch to turn on the hazard warning flashers, all turn signal lamps flash continuously.

To turn them off, push the switch again.

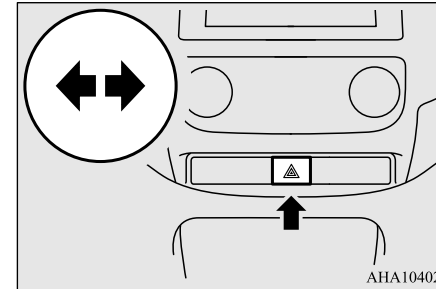

## Front fog lamp switch\*

### NOTE

- On vehicles equipped with the emergency stop signal system, while the hazard warning lamps are blinking due to having manually pushed the switch, the emergency stop signal system does not operate. Refer to “Emergency stop signal system” on page 6-69.

## Front fog lamp switch\*

E00506802130

The front fog lamps can be operated while the headlamps or tail lamps are on. Turn the knob in the “ON” direction to turn on the front fog lamps. An indicator lamp in the instrument cluster will also come on. Turn the knob in the “OFF” direction to turn off the front fog lamps. The knob will automatically return to its original position when you release it.

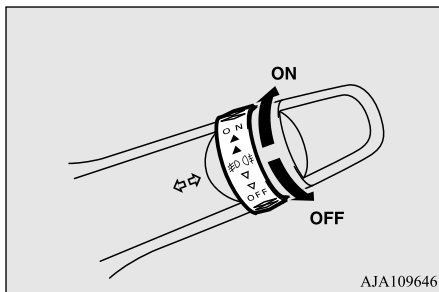

### NOTE

- The front fog lamps are automatically turned off when the headlamps or tail lamps are turned off. To turn the front fog lamps on again, turn the knob in the “ON” direction after turning on the headlamps or tail lamps.
- Do not use fog lamps except in conditions of fog, otherwise excessive lamp glare may temporarily blind oncoming vehicle drivers.

## Wiper and washer switch

E00507102749

The windscreen wipers and washer can be operated with the ignition switch or the operation mode in ON or ACC.

If the blades are frozen to the windscreen, do not operate the wipers until the ice has melted and the blades are freed, otherwise the wiper motor may be damaged.

### CAUTION

- If the washer is used in cold weather, the washer fluid sprayed against the glass may freeze, which may hinder visibility. Warm the glass with the defroster or rear window demister before using the washer.

## Windscreen wipers

E00516902163

### Except for vehicles equipped with rain sensor

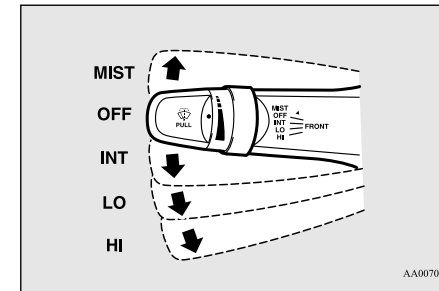

5

- MIST- Misting function  
The wipers will operate once.
- OFF- Off
- INT- Intermittent (Speed sensitive)
- LO- Slow
- HI- Fast

### To adjust intermittent intervals

With the lever in the “INT” (speed sensitive intermittent operation) position, the intermittent intervals can be adjusted by turning the knob (A).



## Wiper and washer switch

5

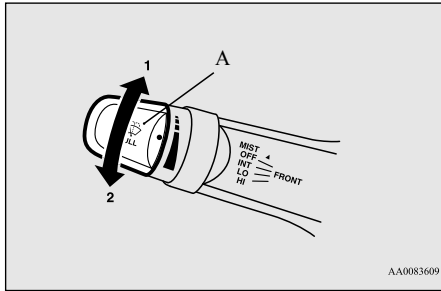

- 1- Fast
- 2- Slow

### NOTE

- The speed-sensitive-operation function of the windscreen wipers can be deactivated. For further information, we recommend you to consult an authorised MITSUBISHI MOTORS dealer.

### Misting function

Move the lever in the direction of the arrow and release, to operate the wipers once.

Use this function when you are driving in mist or drizzle.

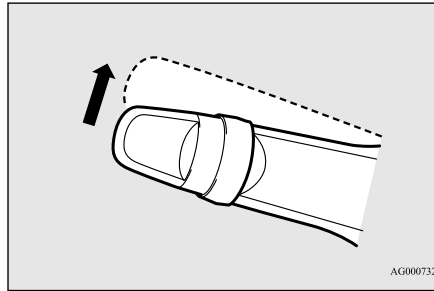

### Vehicles equipped with rain sensor

E00517001643

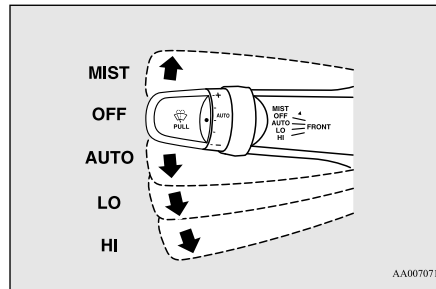

- MIST- Misting function  
The wipers will operate once.
- OFF- Off
- AUTO- Auto-wiper control  
Rain sensor

The wipers will automatically operate depending on the degree of wetness on the windscreen.

- LO- Slow
- HI- Fast

### Rain sensor

Can only be used when the ignition switch or the operation mode is in ON.

If the lever is put in the “AUTO” position, the rain sensor (A) will detect the extent of rain (or snow, other moisture, dust, etc.) and the wipers will operate automatically.

Keep the lever in the “OFF” position if the windscreen is dirty and the weather is dry.

Wiper operation under these conditions can scratch the windscreen and damage the wipers.

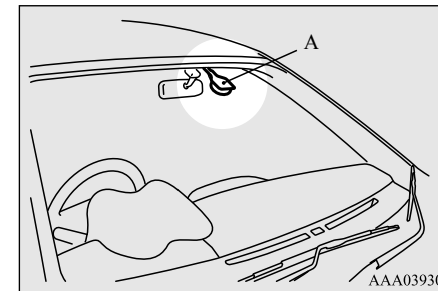

**CAUTION**

- With the ignition switch or the operation mode in ON and the lever in the “AUTO” position, the wipers may automatically operate in the situations described below. If your hands get trapped, you could suffer injuries or the wipers could malfunction. Be sure to turn the ignition switch to the “LOCK” position or put the operation mode in OFF, or move lever to the “OFF” position to deactivate the rain sensor.
- When cleaning the outside surface of the windscreen, if you touch on top of the rain sensor.
- When cleaning the outside surface of the windscreen, if you wipe with a cloth on top of the rain sensor.
- When using an automatic car wash.
- A physical shock is applied to the windscreen.
- A physical shock is applied to the rain sensor.

**NOTE**

- To protect the rubber parts of the wipers, this operation of the wipers does not take place even if the lever is put in the “AUTO” position when the vehicle is stationary and the ambient temperature is about 0 °C or lower.

**NOTE**

- Do not cover the sensor by affixing a sticker or label to the windscreen. Also, do not put any water-repellent coating on the windscreen. The rain sensor would not be able to detect the extent of rain, and the wipers might stop working normally.
- In the following cases, the rain sensor may be malfunctioning. For further information, we recommend you to consult an authorised MITSUBISHI MOTORS dealer.
  - When the wipers operate at a constant interval despite changes in the extent of rain.
  - When the wipers do not operate even though it is raining.
- The wipers may automatically operate when things such as insects or foreign objects are affixed to the windscreen on top of the rain sensor or when the windscreen is frozen. Objects affixed to the windscreen will stop the wipers when the wipers cannot remove them. To operate the wipers again, move the lever in the “LO” or “HI” position. Also, the wipers may operate automatically due to strong direct sunlight or electromagnetic wave. To stop the wipers, place the lever in the “OFF” position.
- Contact an authorised MITSUBISHI MOTORS dealer when replacing the windscreen or reinforcing the glass around the sensor.

**To adjust the sensitivity of the rain sensor**

With the lever in the “AUTO” (rain sensor) position, it is possible to adjust the sensitivity of the rain sensor by turning the knob (B).

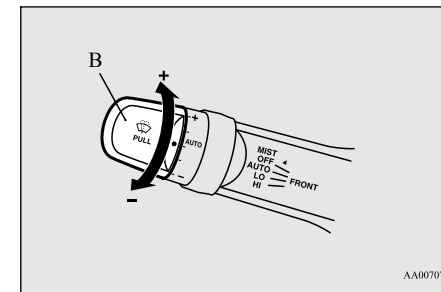

**5**

“+”- Higher sensitivity to rain  
 “-”- Lower sensitivity to rain

**NOTE**

- It is possible to activate the following functions:
    - Automatic operation (rain droplet sensitive) can be changed to intermittent operation (vehicle-speed sensitive).
    - Automatic operation (rain droplet sensitive) can be changed to intermittent operation (except vehicle-speed sensitive).
- For further information, we recommend you to consult an authorised MITSUBISHI MOTORS dealer.

## Wiper and washer switch

### Misting function

Move the lever in the direction of the arrow and release, to operate the wipers once.

Use this function when you are driving in mist or drizzle.

5

The wipers will operate once if the lever is raised to the “MIST” position and released when the ignition switch or the operation mode is in ON or ACC. The wipers will continue to operate while the lever is held in the “MIST” position.

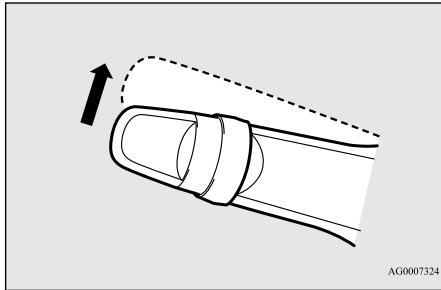

The wipers will operate once if the lever is moved to the “AUTO” position and the knob (C) is turned in the “+” direction when the ignition switch is in the “ON” position or the operation mode is in ON.

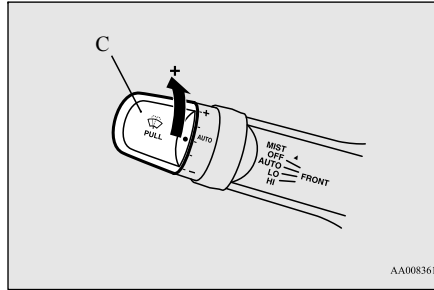

### Windscreen washer

E00507202362

The washer fluid will be sprayed onto the windscreen by pulling the lever towards you. The wipers operate automatically several times while the washer fluid is being sprayed.

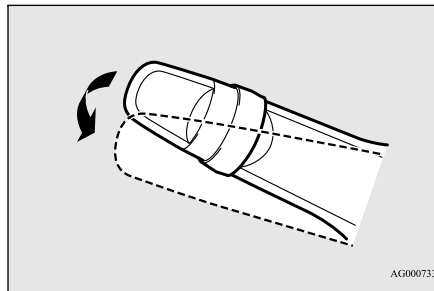

### CAUTION

- If the washer is used in cold weather, the washer fluid sprayed against the glass may freeze resulting in poor visibility. Heat the glass with the defroster or demister before using the washer.

### Precautions to observe when using wipers and washers

E00507601604

- If the moving wipers become blocked partway through a sweep by ice or other deposits on the glass, the wipers may temporarily stop operating to prevent the motor from overheating. In this case, park the vehicle in a safe place, turn the ignition switch to the “LOCK” position or put the operation mode in OFF, and then remove the ice or other deposits. Because the wipers will start operating again after the wiper motor cools down, check that the wipers operate before using them.
- Do not use the wipers when the glass is dry. They may scratch the glass surface and the blades wear out prematurely.
- Before using the wipers in cold weather, check that the wiper blades are not frozen onto the glass. The motor may burn out if the wipers are used with the blades frozen onto the glass.

- Avoid using the washer continuously for more than 20 seconds. Do not operate the washer when the fluid reservoir is empty. Otherwise, the motor may burn out.
- Periodically check the level of washer fluid in the reservoir and refill if required. During cold weather, add a recommended washer solution that will not freeze in the washer reservoir. Failure to do so could result in loss of washer function and frost damage to the system components.

## Rear window demister switch\*

E00507902848

The rear window demister switch can be operated when the engine is running. Push the switch to turn on the rear window demister. It will be turned off automatically in about 20 minutes. To turn off the demister within about 20 minutes, push the switch again.

The indicator lamp (A) will illuminate while the demister is on.

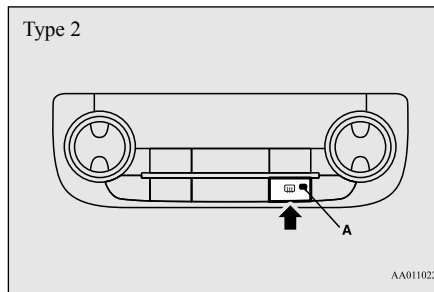
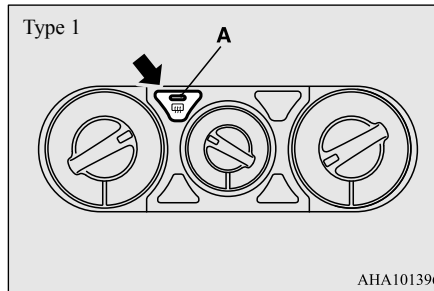

### NOTE

- On vehicles equipped with heated mirrors, when the rear window demister switch is pressed, the outside rear-view mirrors are defogged or defrosted. Refer to “Heated mirror” on page 6-12.
- The demister switch is not to melt snow but to clear mist. Remove snow before use of the demister switch.

## Rear window demister switch\*

### NOTE

- To avoid unnecessary discharge of the battery, do not use the rear window demister during starting of the engine or when the engine is not running. Turn the demister off immediately after the window is clear.
- When cleaning the inside of the rear window, use a soft cloth and wipe gently along the heater wires, being careful not to damage the wires.
- Do not allow objects to touch the inside of the rear window glass, damaged or broken wires may result.

5

## Customizing the automatic rear window demister (Vehicles equipped with the rear window demister switch - Type 2)

Function can be changed as desired, as stated below.

- Enable automatic rear window demister:  
If the outside air temperature drops below approx. 3 °C (37 °F), the rear window demister operates once automatically after the engine starts.  
The heated mirrors will also operate once automatically at the same time.
- Disable automatic rear window demister:

## Horn switch

The rear window demister does not operate automatically.

The heated mirrors will not operate automatically as well.

● **Setting change method:**

Hold down the rear window demister switch for about 10 seconds or more.

- When the setting is changed from enable to disable  
3 sounds are emitted and the indicator lamp flashes 3 times.
- When the setting is changed from disable to enable  
2 sounds are emitted and the indicator lamp flashes 3 times.

**5**

### **NOTE**

- The factory setting is “Disable automatic rear window demister”.

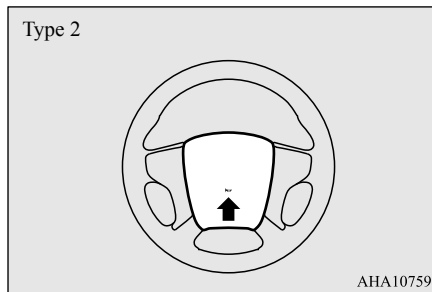
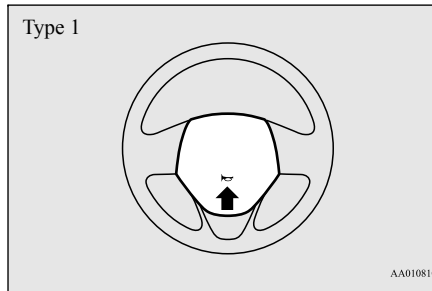

## Horn switch

E00508001793

Press the steering wheel on or around the “” mark.

## *Starting and driving*

Economical driving .....	6-2	Brake assist system* .....	6-68
Driving, alcohol and drugs .....	6-3	Emergency stop signal system* .....	6-69
Safe driving techniques .....	6-3	Anti-lock brake system (ABS) .....	6-69
Running-in recommendations .....	6-4	Power steering system .....	6-72
Parking brake .....	6-5	Active Stability & Traction Control (ASTC)* .....	6-72
Parking .....	6-6	Cruise control* .....	6-76
Steering wheel height and reach adjustment .....	6-7	Forward Collision Mitigation system (FCM)* .....	6-80
Inside rear-view mirror .....	6-8	Ultrasonic misacceleration Mitigation System (UMS)* .....	6-90
Outside rear-view mirrors .....	6-9	Blind Spot Warning (BSW) (with Lane Change Assist)* .....	6-95
Ignition switch* .....	6-13	Rear Cross Traffic Alert (RCTA)* .....	6-99
Engine switch* .....	6-14	Reversing sensor system* .....	6-101
Steering wheel lock .....	6-16	Sensor system* .....	6-105
Starting and stopping the engine .....	6-18	Rear-view camera* .....	6-109
Turbocharger operation* .....	6-22	Multi Around Monitor* .....	6-112
Auto Stop & Go (AS&G) system* .....	6-22	Cargo loads .....	6-121
Manual transmission* .....	6-27		
Automatic transmission Sports Mode 6A/T* .....	6-29		
Easy Select 4WD* .....	6-35		
Super Select 4WD II* .....	6-42		
Off Road mode* .....	6-49		
Rear differential lock* .....	6-51		
4-wheel drive operation* .....	6-56		
Inspection and maintenance following rough road operation .....	6-62		
Cautions on handling of 4-wheel drive vehicles* .....	6-62		
Limited-slip differential* .....	6-64		
Braking .....	6-64		
Hill start assist* .....	6-65		
Hill Descent Control (HDC)* .....	6-66		

## Economical driving

### Economical driving

E00600102770

For economical driving, there are some technical requirements that have to be met. The prerequisite for low fuel consumption is a properly adjusted engine. In order to achieve longer life of the vehicle and the most economical operation, we recommend you to have the vehicle checked at regular intervals in accordance with the service standards.

Fuel economy and generation of exhaust gas and noise are highly influenced by personal driving habits as well as the particular operating conditions. The following points should be observed in order to minimize wear of brakes, tyres and engine as well as to reduce environmental pollution.

### Accelerating and decelerating

Drive according to traffic conditions, and avoid sudden starts, sudden acceleration, and sudden braking, as they will increase fuel consumption.

### Shifting

Shift only at an appropriate speed and engine speed. Always use the highest shift position possible.

The drive mode-selector should be set to “2H” when driving 4WD vehicles on normal roads and express ways to obtain best possible fuel economy.

### City traffic

Frequent starting and stopping increases the average fuel consumption. Use roads with smooth traffic flow whenever possible. When driving on congested roads, avoid use of a low shift position at high engine speeds.

### Idling

The vehicle consumes fuel even during idling. Avoid extended idling whenever possible.

### Speed

At higher the vehicle speed, more fuel is consumed. Avoid driving at full speed. Even a slight release of the accelerator pedal will save a significant amount of fuel.

### Tyre inflation pressure

Check the tyre inflation pressures at regular intervals. Low tyre inflation pressure increases road resistance and fuel consumption. In addition, low tyre pressures adversely affect tyre wear and driving stability.

### Cargo loads

Do not drive with unnecessary articles in the luggage compartment. Especially during city driving where frequent starting and stopping is necessary, the increased weight of the vehicle will greatly affect fuel consumption. Also avoid driving with unnecessary luggage or carriers, etc., on the roof; the increased air resistance will increase fuel consumption.

### Cold engine starting

Starting of a cold engine consumes more fuel. Unnecessary fuel consumption is also caused by keeping a hot engine running. After the engine is started, commence driving as soon as possible.

### Cooler or air conditioning

The use of the air conditioning will increase the fuel consumption.

### Driving, alcohol and drugs

E00600200070

Drunk driving is one of the most frequent causes of accidents.

Your driving ability can be seriously impaired even with blood alcohol levels far below the legal minimum. If you have been drinking, don't drive. Ride with a designated non-drinking driver, call a cab or a friend, or use public transportation. Drinking coffee or taking a cold shower will not make you sober.

Similarly, prescription and nonprescription drugs affect your alertness, perception and reaction time. Consult with your doctor or pharmacist before driving while under the influence of any of these medications.

#### ⚠ WARNING

- **NEVER DRINK AND DRIVE.**  
Your perceptions are less accurate, your reflexes are slower and your judgment is impaired.

### Safe driving techniques

E00600300446

Driving safety and protection against injury cannot be fully ensured. However, we recommend that you pay extra attention to the following:

#### Seat belts

Before starting the vehicle, make sure that you and your passengers have fastened your seat belts.

#### Floor mats

#### ⚠ WARNING

- **Keep floor mats clear of the pedals by correctly laying floor mats that are suitable for the vehicle.**  
To prevent the floor mats from slipping out of position, securely retain them using the hook etc.  
Note that laying a floor mat over a pedal or laying one floor mat on top of another can obstruct pedal operation and lead to a serious accident.

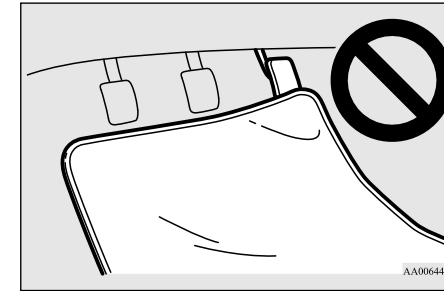

6

### Carrying children in the vehicle

- Never leave your vehicle unattended with the key and children inside the vehicle. Children may play with the driving controls and this could lead to an accident.
- Make sure that infants and small children are properly restrained in accordance with the laws and regulations, and for maximum protection in case of an accident.
- Prevent children from playing in the luggage compartment. It is quite dangerous to allow them to play there while the vehicle is moving.

### Loading luggage

When loading luggage, be careful not to load above the height of seats. This is dangerous



## Running-in recommendations

not only because rearward vision will be obstructed, but also the luggage may be projected into the passenger compartment under hard braking.

### Running-in recommendations

E00600404676

**6**

During the running-in period for the first 1,000 km, it is advisable to drive your new vehicle using the following precautions as a guideline to aid long life as well as future economy and performance.

- Do not race the engine at high speeds.
- Avoid rapid starting, accelerating, braking and prolonged high-speed running.
- Keep to the running-in speed limit shown below.  
Please note that the legal speed limits displayed must be adhered to.
- Do not exceed loading limits.
- Refrain from towing a trailer.

## Vehicles with M/T

### 4D56

Shift point	Speed limit
1st gear	20 km/h
2nd gear	40 km/h
3rd gear	65 km/h
4th gear	95 km/h
5th gear	110 km/h

### 4N15

#### ■ 2WD models

Shift point	Speed limit
1st gear	20 km/h
2nd gear	40 km/h
3rd gear	65 km/h
4th gear	95 km/h
5th gear	115 km/h
6th gear	

#### ■ Vehicles with Easy Select 4WD

Shift point	Speed limit	
	2H, 4H	4L
1st gear	20 km/h	5 km/h
2nd gear	40 km/h	15 km/h
3rd gear	65 km/h	25 km/h
4th gear	95 km/h	35 km/h
5th gear	110 km/h	45 km/h
6th gear		55 km/h

#### ■ Vehicles with Super Select 4WD II

Shift point	Speed limit	
	2H, 4H, 4HLc	4LLc
1st gear	20 km/h	5 km/h
2nd gear	40 km/h	15 km/h
3rd gear	70 km/h	25 km/h
4th gear	100 km/h	35 km/h
5th gear	115 km/h	50 km/h
6th gear		60 km/h

**Vehicles with A/T**

**2WD models**

Shift point	Speed limit
1st gear	15 km/h
2nd gear	35 km/h
3rd gear	50 km/h
4th gear	75 km/h
5th gear	115 km/h
6th gear	

**Vehicles with Easy Select 4WD**

Shift point	Speed limit	
	2H, 4H	4L
1st gear	10 km/h	5 km/h
2nd gear	35 km/h	10 km/h
3rd gear	45 km/h	15 km/h
4th gear	75 km/h	25 km/h
5th gear	110 km/h	40 km/h
6th gear		45 km/h

**Vehicles with Super Select 4WD II**

Shift point	Speed limit	
	2H, 4H, 4HLc	4LLc
1st gear	15 km/h	5 km/h
2nd gear	35 km/h	10 km/h
3rd gear	50 km/h	20 km/h
4th gear	75 km/h	30 km/h
5th gear	115 km/h	45 km/h
6th gear		

**CAUTION**

- On 4WD vehicles, the “4L” (Easy Select 4WD), “4LLc” (Super Select 4WD II) range gives maximum torque for low-speed driving on steep slopes, as well as sandy, muddy, and other difficult surfaces. On vehicles with A/T, do not exceed speeds of approximately 70 km/h in “4L” (Easy Select 4WD), “4LLc” (Super Select 4WD II) range.

**Parking brake**

E00600503003

To park the vehicle, first bring it to a complete stop, fully apply the parking brake sufficiently to hold the vehicle.

**To apply**

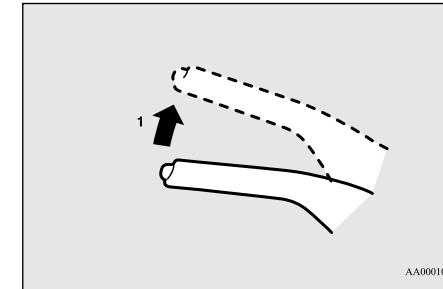

- 1- Firmly depress and hold the brake pedal, then pull the lever up without pushing the button at the end of hand grip.

**CAUTION**

- When you intend to apply the parking brake, firmly press the brake pedal to bring the vehicle to a complete stop before pulling the parking brake lever. Pulling the parking brake lever with the vehicle moving could make the rear wheels lock up, thereby making the vehicle unstable. It could also make the parking brake malfunction.

**6**

## Parking

### NOTE

- Apply sufficient force to the parking brake lever to hold the vehicle stationary after the foot brake is released.
- If the parking brake does not hold the vehicle stationary after the foot brake is released, contact your authorised MITSUBISHI MOTORS dealer.

6

### To release

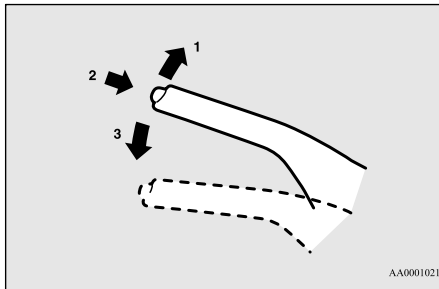

- 1- Firmly depress and hold the brake pedal, then pull the lever up slightly.
- 2- Push the button at the end of hand grip.
- 3- Lower the lever fully.

### CAUTION

- Before driving, be sure that the parking brake is fully released and brake warning lamp is off.  
If you drive without the parking brake fully released, the warning display will appear on the information screen in the multi information display and a buzzer sound when the vehicle speed exceeds 8 km/h.  
If a vehicle is driven without releasing the parking brake, the brake will be overheated, resulting in ineffective braking and possible brake failure.

Warning lamp



Warning display



- If the brake warning lamp does not extinguish when the parking brake is fully released, the brake system may be abnormal.  
Contact your authorised MITSUBISHI MOTORS dealer.  
For details, refer to “Brake warning lamp” on page 5-50.

### NOTE

- To prevent the parking brake from being released unintentionally, the lever must be pulled up slightly before it can be pushed down. Simply pressing the button does not enable the lever to be pushed down.

## Parking

E00600602704

To park the vehicle, fully engage the parking brake, and then move the gearshift lever to 1st or “R” (Reverse) position for vehicles equipped with M/T, or set the selector lever to “P” (PARK) position for vehicles equipped with A/T.

### Parking on a hill

To prevent the vehicle from rolling, follow these procedures:

### Parking on a downhill slope

Turn the front wheels towards the kerb and move the vehicle forward until the kerb side wheel gently touches the kerb.  
On vehicles equipped with M/T, apply the parking brake and place the gearshift lever into the “R” (Reverse) position.

On vehicles equipped with A/T, apply the parking brake and place the selector lever into the “P” (PARK) position.  
If necessary, apply chocks to wheels.

### Parking on an uphill slope

Turn the front wheels away from the kerb and move the vehicle back until the kerb side wheel gently touches the kerb.

On vehicles equipped with M/T, apply the parking brake and place the gearshift lever into the 1st position.

On vehicles equipped with A/T, apply the parking brake and place the selector lever into the “P” (PARK) position.

If necessary, apply chocks to wheels.

### NOTE

- If your vehicle is equipped with A/T, be sure to apply the parking brake before moving selector lever to the “P” (PARK) position. If you move selector lever to the “P” (PARK) position before applying the parking brake, it may be difficult to disengage selector lever from the “P” (PARK) position when next you drive the vehicle, requiring application of a strong force the selector lever to move from the “P” (PARK) position.

### Parking with the engine running

Never leave the engine running while you take a short sleep/rest. Also, never leave the engine running in a closed or poorly ventilated place.

### WARNING

- Leaving the engine running risks injury or death from accidentally moving the gearshift lever (with M/T) or the selector lever (with A/T) or the accumulation of toxic exhaust fumes on the passenger compartment.

### Where you park

### WARNING

- Do not park your vehicle in areas where combustible materials such as dry grass or leaves can come in contact with a hot exhaust, since a fire could occur.

### When leaving the vehicle

Always carry the key and lock all doors when leaving the vehicle unattended.

### Steering wheel height and reach adjustment

Always try to park your vehicle in a well lit area.

### Steering wheel height and reach adjustment

E00600701711

1. Release the lever while holding the steering wheel up.
2. Adjust the steering wheel to the desired position.
3. Securely lock the steering wheel by pulling the lever fully upward.

6

## Inside rear-view mirror

6

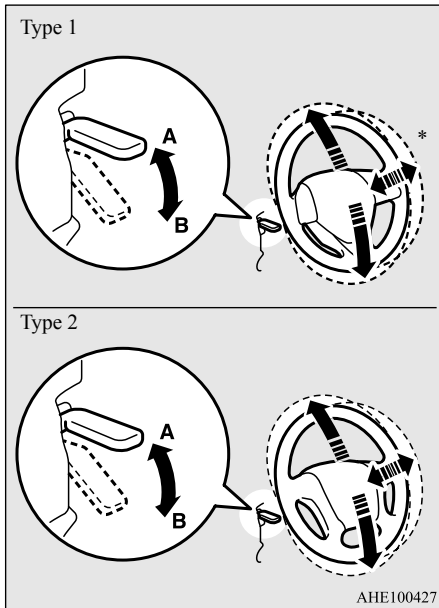

A- Locked

B- Release

\*: Vehicles equipped with the reach adjustment

### **⚠ WARNING**

- Do not attempt to adjust the steering wheel while you are driving the vehicle.

### **Inside rear-view mirror**

E00600802155

Adjust the rear-view mirror only after making any seat adjustments so you have a clear view to the rear of the vehicle.

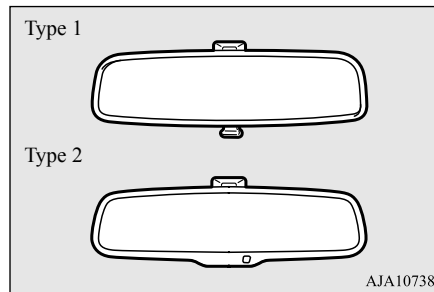

### **⚠ WARNING**

- Do not attempt to adjust the rear-view mirror while driving. This can be dangerous. Always adjust the mirror before driving.

Adjust the rear-view mirror to maximize the view through the rear window.

### **To adjust the vertical mirror position**

It is possible to move the mirror up and down to adjust its position.

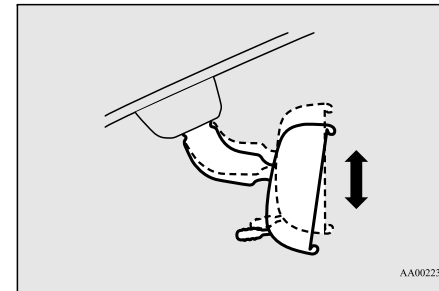

### **To adjust the mirror position**

It is possible to move the mirror up/down and left/right to adjust its position.

## Outside rear-view mirrors

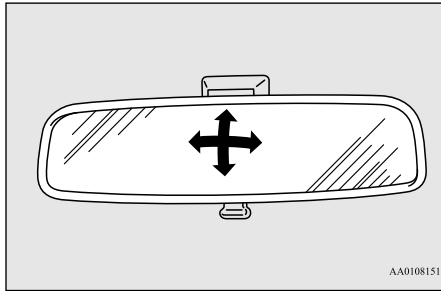

### To reduce the glare

#### Type 1

The lever (A) at the bottom of the mirror can be used to adjust the mirror to reduce the glare from the headlamps of vehicles behind you during night driving.

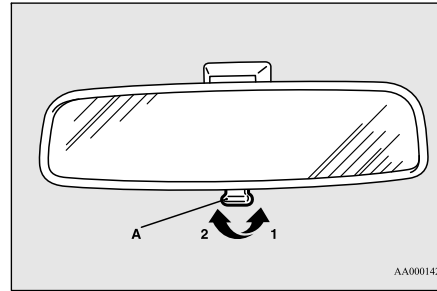

- 1- Normal
- 2- Anti-glare

#### Type 2

When the headlamps of the vehicles behind you are very bright, the reflection factor of the rear-view mirror is automatically changed to reduce the glare.

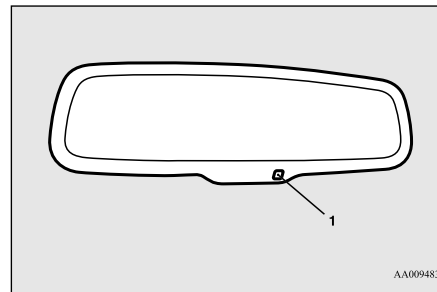

When the ignition switch is turned to the "ON" position or the operation mode is put in ON, the reflection factor of the mirror is automatically changed.

#### NOTE

- Do not hang items on, or spray glass cleaner on the sensor (1), as reduced sensitivity could result.

### Outside rear-view mirrors

E00600900628

### To adjust the mirror position

E00601002213

#### WARNING

- **Do not attempt to adjust the rear-view mirrors while driving. This can be dangerous.**  
Always adjust the mirrors before driving.
- **Your vehicle is equipped with convex type mirrors.**  
Please take into consideration, but objects you see in the mirror will look smaller and farther away compared to a normal flat mirror.  
Do not use this mirror to estimate distance of following vehicles when changing lanes.

6

## Outside rear-view mirrors

### Manual outside rear-view mirrors\*

Adjust the mirror surface by hands as indicated by the arrows.

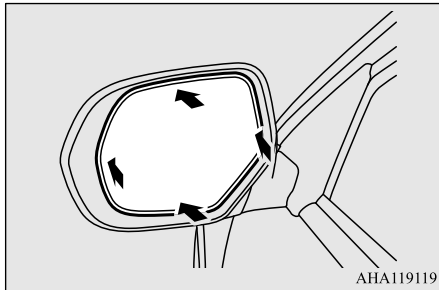

6

### Electric remote-controlled outside rear-view mirrors\*

The electric remote-controlled outside rear-view mirrors can be operated when the ignition switch is in the "ON" or "ACC" position or the operation mode is put in ON or ACC.

1. Place the lever (A) to the same side as the mirror whose adjustment is desired.

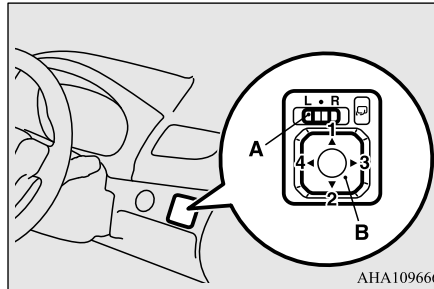

- L- Left outside mirror adjustment  
R- Right outside mirror adjustment

2. Press the switch (B) to the left, right, up or down to adjust the mirror position.

- 1- Up
- 2- Down
- 3- Right
- 4- Left

3. Return the lever (A) back to the middle position (•).

### Retracting and extending the outside mirrors

E00601102618

The outside mirror can be retracted in towards the side window to prevent damage when parking in narrow areas.

### CAUTION

- Do not drive the vehicle with the mirror retracted in.  
The lack of rearward visibility normally provided by the mirror could lead to an accident.

### Except for vehicles equipped with the mirror retractor switch

Push the mirror towards the back of the vehicle with your hand to retract it in. When extending the mirror, pull it out towards the front of the vehicle until it clicks to lock in place.

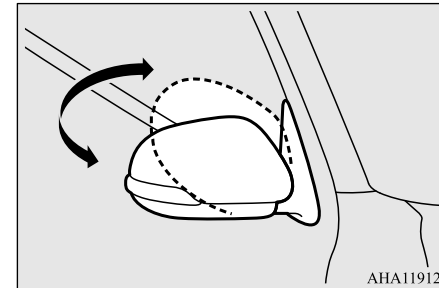

**For vehicles equipped with the mirror retractor switch**

### Retracting and extending the mirrors using the mirror retractor switch

With the ignition switch or the operation mode in ON or ACC, push the mirror retractor switch to retract the mirrors.

Push it again to extend the mirrors to their original positions.

After turning the ignition switch to the "LOCK" position or putting the operation mode in OFF, it is possible to retract and extend the mirrors using the mirror retractor switch for about 30 seconds.

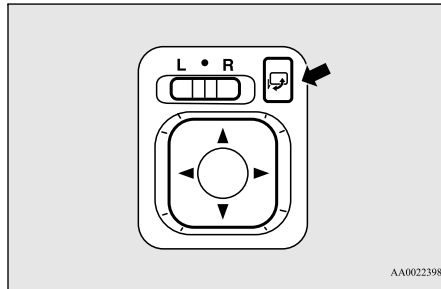

### CAUTION

- It is possible to retract and extend the mirrors by hand. After retracting a mirror using the mirror retractor switch, however, you should extend it by using the switch again, not by hand. If you extended the mirror by hand after retracting it using the switch, it would not properly lock in position. As a result, the mirror could move because of the wind or vibration while you are driving, and this may prevent the driver's rearward visibility.

### NOTE

- Be careful not to get your hands trapped while a mirror is moving.
- If you move a mirror by hand or it moves after hitting a person or object, you may not be able to return it to its original position using the mirror retractor switch. If this happens, push the mirror retractor switch to place the mirror in its retracted position and then push the switch again to return the mirror to its original position.
- When freezing has occurred and mirrors fail to operate as intended, please refrain from repeated pushing of the retractor switch as this action can result in burn-out of the mirror motor circuits.

### Retracting and extending the mirrors without using the mirror retractor switch

[Except for vehicles equipped with the keyless entry key or the keyless operation key]  
The mirrors automatically extend when the vehicle speed reaches 30 km/h.

[Vehicles equipped with keyless entry key]  
The mirrors automatically retract or extend when the doors are locked or unlocked using the key switches of the keyless entry system. Refer to "Keyless entry system" on page 3-4.

[Vehicles with the keyless operation system]  
The mirrors automatically retract or extend when the doors are locked or unlocked using the key switches or the keyless operation function of the keyless operation system. Refer to "Keyless entry system" on page 3-4. Refer to "Keyless operation system: To operate using the keyless operation function" on pages 3-10.

### NOTE

- Functions can be modified as stated below. Please consult an authorised MITSUBISHI MOTORS dealer.



## Outside rear-view mirrors

6

### NOTE

- Automatically extend when the driver's door is closed, and then the following operation is performed.  
[Except for vehicles equipped with the keyless operation system]  
Turn the ignition switch to the "ON" position.  
[Vehicles equipped with the keyless operation system]  
Put the operation mode in ON.
- Automatically retract when the ignition switch is turned to the "LOCK" or "ACC" position or the operation mode is put in OFF or ACC, and the driver's door is then opened.
- Automatically extend when the vehicle speed reaches approximately 30 km/h. (vehicles equipped with the keyless entry key or the keyless operation key)

### NOTE

- Deactivate the automatic extension function.  
  
The outside rear-view mirrors can be retracted or extended by the following operations, even if changing to the any of above.  
After pressing the "LOCK" switch to lock the doors, if the "LOCK" switch is pressed again twice in a row within approximately 30 seconds, the outside rear-view mirrors will retract.  
After pressing the "UNLOCK" switch to unlock the doors, if the "UNLOCK" switch is pressed again twice in a row within approximately 30 seconds, the outside rear-view mirrors will extend again.

### Heated mirror\*

E00601201843

To demist or defrost the outside rear-view mirrors, press the rear window demister switch.

The indicator lamp (A) will illuminate while the demister is on.

The heater will be turned off automatically in approximately 20 minutes depending on the outside temperature.

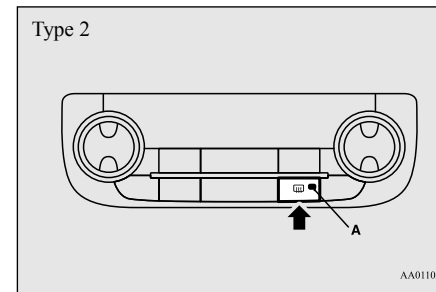
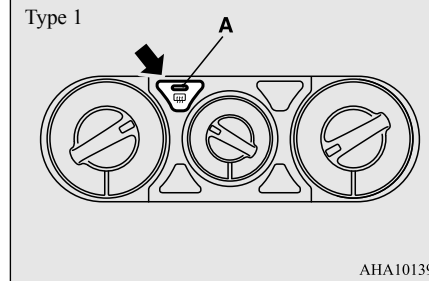

### NOTE

- The heater mirrors can be turned on automatically.  
For further information, we recommend you to consult an authorised MITSUBISHI MOTORS dealer.

## Ignition switch\*

E00601403302

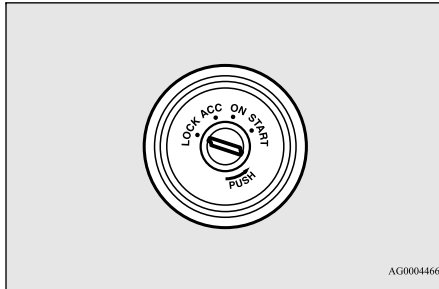

## LOCK

The engine is stopped and the steering wheel locked. The key can only be inserted and removed in this position.

## ACC

The engine is stopped, but the audio system and other electric devices can be operated.

## ON

All the vehicle's electrical devices can be operated.

## START

The starter motor operates. After the engine has started, release the key and it will automatically return to the "ON" position.

### NOTE

- If your vehicle is equipped with an electronic immobilizer. To start the engine, the ID code which the transponder inside the key sends must match the one registered in the immobilizer computer. Refer to "Electronic immobilizer (Anti-theft starting system)" on page 3-3.

## To remove the key

E00620401538

For vehicles equipped with a M/T, when removing the key, push the key in at the "ACC" position and keep it depressed until it is turned to the "LOCK" position and remove it.

For vehicles equipped with A/T, when removing the key, first set the selector lever to the "P" (PARK) position, and push the key in at the "ACC" position and keep it depressed until it is turned to the "LOCK" position, and remove it.

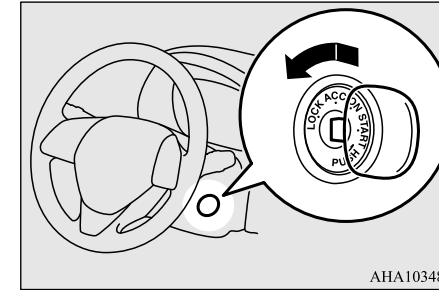

### CAUTION

- Do not remove the ignition key from the ignition switch while driving. The steering wheel will be locked, causing loss of control.
- If the engine is stopped while driving, the brake servomechanism will cease to function and braking efficiency will deteriorate. Also, the power steering system will not function and it will require greater manual effort to operate the steering.
- Do not leave the key in the "ON" position for a long time when the engine is not running, doing so will cause the battery to be discharged.
- Do not turn the key to the "START" position while the engine is running. Doing so could damage the starter motor.

## Engine switch\*

### Engine switch\*

E00631801721

In order to prevent theft, the engine will not start unless a preregistered keyless operation key is used. (Engine immobilizer function)  
If you are carrying the keyless operation key, you can start the engine.

6

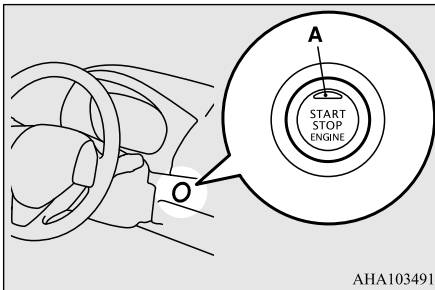

### CAUTION

- The indicator lamp (A) will flash orange when there is a problem or malfunction in the keyless operation system. Never drive if the indicator lamp on the engine switch is flashing orange. Immediately contact your authorised MITSUBISHI MOTORS dealer.
- If the engine switch operation is not smooth and feels like it is sticking, do not operate the switch. Immediately contact your authorised MITSUBISHI MOTORS dealer.

### NOTE

- When operating the engine switch, press the switch all the way in. If the switch is not fully pressed, the engine may not start or the operation mode may not change. If the engine switch is pressed correctly, there is no need to hold the engine switch down.
- When the battery in the keyless operation key has worn out, or the keyless operation key is out of the vehicle, a warning lamp will blink for 5 seconds or warning display will appear.

Warning lamp (mono-color liquid crystal display)



Warning display (color liquid crystal display)

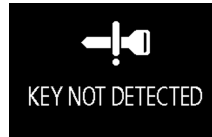

### Operation mode of the engine switch and its function

#### OFF

The indicator lamp on the engine switch turns off.

The operation mode cannot be put in OFF when the selector lever is in any position other than the “P” (PARK) position (A/T).

#### ACC

Electrical devices such as the audio and accessory socket can be operated.

The indicator lamp on the engine switch illuminates orange.

#### ON

All vehicle's electrical devices can be operated.

The indicator lamp on the engine switch illuminates green. The indicator lamp turns off when the engine is running.

**NOTE**

- Your vehicle is equipped with an electronic immobilizer. To start the engine, the ID code which the transponder inside the key sends must match the one registered in the immobilizer computer. Refer to “Electronic immobilizer (Anti-theft starting system)” on page 3-3.

### Changing the operation mode

E00631901360

If you press the engine switch without depressing the brake pedal (A/T) or the clutch pedal (M/T), you can change the operation mode in the order of OFF, ACC, ON, OFF.

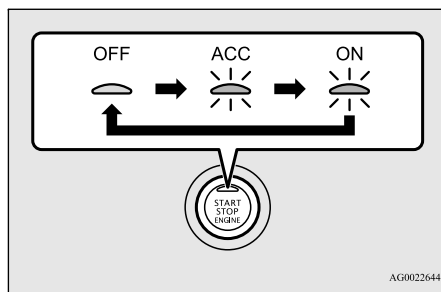

AG0022644

**CAUTION**

- When the engine is not running, put the operation mode in OFF. Leaving the operation mode in ON or ACC for a long time when the engine is not running may cause the battery to be discharged, making it impossible to start the engine, lock and unlock the steering wheel.
- When the battery is disconnected, the current operation mode is memorized. After reconnecting the battery, the memorized mode is selected automatically. Before disconnecting the battery for repair or replacement, make sure to put the operation mode in OFF. Be careful if you are not sure which operation mode the vehicle is in when the battery is run down.
- The operation mode cannot be changed from OFF to ACC or ON if the keyless operation key is not detected to be in the vehicle. Refer to “Keyless operation system: Operating range for starting the engine and changing the operation mode” on page 3-10.
- When there is the keyless operation key in the vehicle and the operation mode isn't change, the keyless operation key may have worn out.

**NOTE**

- If the operation mode cannot be changed to OFF, perform the following procedure.

**NOTE**

- Move the selector lever to the “P” (PARK) position, and then change the operation mode to OFF. (For vehicles with A/T)
- One of the other causes could be low battery voltage. If this occurs, the keyless entry system, keyless operation function, and steering lock will also not operate. Contact an authorised MITSUBISHI MOTORS dealer.

### ACC power auto-cutout function

E00632801672

After about 30 minutes has elapsed with the operation mode in ACC, the function automatically cuts out the power for the audio system and other electric devices that can be operated with that position. (only that driver's door has closed and the selector lever in the “P” (PARK) position)

When you open driver's door or the engine switch operate again, the power is supplied again.

**NOTE**

- When ACC power supply automatic stop, the steering wheel can't lock and you can't lock and unlock the doors by the keyless entry system.

## Steering wheel lock

### NOTE

- It is possible to modify functions as follows:
    - The time until the power cuts out can be changed to about 60 minutes.
    - The ACC power auto-cutout function can be deactivated.
- For details, consult an authorised MITSUBISHI MOTORS dealer.

6

### Operation mode OFF reminder system

E00632201689

Warning lamp (mono-color liquid crystal display)



Warning display (color liquid crystal display)



When the operation mode is in any mode other than OFF, if you try to lock the doors by pressing the driver's or front passenger's door lock/unlock switch, a warning passenger will blink or warning display will appear and the outer buzzer will sound and you cannot lock the doors.

6-16 Starting and driving

### Operation mode ON reminder system

E00632301198

If the driver's door is opened with the engine stopped and the operation mode in any mode other than OFF, the operation mode ON reminder inner buzzer sounds intermittently to remind you to put the operation mode in OFF.

Warning display (color liquid crystal display)



### Steering wheel lock

E00601502654

**Except for vehicles equipped with the keyless operation system**

### To lock

Remove the key at the "LOCK" position. Turn the steering wheel until it is locked.

### To unlock

Turn the key to the "ACC" position while moving the steering wheel slightly right and left.

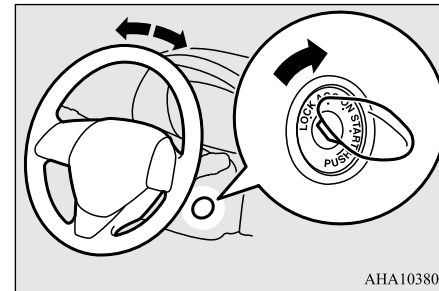

AHA103808

### CAUTION

- Remove the key when leaving the vehicle. In some countries, it is prohibited to leave the key on the vehicle when parked.

**For vehicles equipped with the keyless operation system**

### To lock

After pressing the engine switch and operation mode in OFF, when driver's door is opened, the steering wheel is locked.

**NOTE**

- When the following operation is performed with the operation mode in OFF and the selector lever is in the “P” (PARK) position (A/T), the steering wheel is locked.
  - Open or close the driver’s door.
  - Close all the doors.
  - Open one of the doors when all the doors are closed.
  - Lock all the doors with the keyless entry system or the keyless operation function.
- When the driver’s door is opened while the steering wheel does not lock, warning display will appear and the buzzer sounds to alert the steering wheel is unlocked.



### To unlock

The following methods can be used to unlock the steering wheel.

- Put the operation mode in ACC.
- Start the engine.

**CAUTION**

- If the engine is stopped while driving, do not open a door or press the LOCK switch on the key until the vehicle stops in a safe place. This could cause the steering wheel to lock, making it impossible to operate the vehicle.
- Carry the key with you when leaving the vehicle.  
If your vehicle needs to be towed, unlock the steering wheel. Refer to “Towing: Emergency towing” on page 8-19.

**NOTE**

- When the steering wheel does not unlock, the warning lamp will blink and the inner buzzer will sound and warning lamp illuminates. Press the engine switch again while moving the steering wheel slightly right and left.

Warning lamp (mono-color liquid crystal display)



Warning display (color liquid crystal display)



**NOTE**

- When the steering wheel lock is abnormal, the warning lamp illuminates or warning display will appear and the inner buzzer will sound. Put the operation mode in OFF and then press the lock switch of the keyless operation key. And then press the engine switch. If the warning lamp illuminates again, contact an authorised MITSUBISHI MOTORS dealer.

Warning lamp (mono-color liquid crystal display)



Warning display (color liquid crystal display)



## Starting and stopping the engine

6

### NOTE

- If there is a fault in the steering wheel lock, the warning lamp illuminates and the inner buzzer sounds or warning display will appear. Immediately stop the vehicle in a safe place and contact your nearest authorised MITSUBISHI MOTORS dealer.

Warning lamp (mono-color liquid crystal display)



Warning display (color liquid crystal display)



### Starting and stopping the engine

E00620600272

#### Tips for starting

#### Except for vehicles equipped with the keyless operation system

- Do not operate the starter motor continuously longer than 10 seconds; doing so could run down the battery. If the engine does not start, turn the ignition switch back to “LOCK”, wait a few seconds, and then try again. Trying repeatedly with the starter motor still turning will damage the starter mechanism.

### WARNING

- **Never run the engine in a closed or poorly ventilated area any longer than is needed to move your vehicle in or out of the area. Carbon monoxide gases are odourless and can be fatal.**

### CAUTION

- Never attempt to start the engine by pushing or pulling the vehicle.

### CAUTION

- Do not run the engine at high rpm or drive the vehicle at high speed until the engine has had a chance to warm up.
- Release the ignition key as soon as the engine starts to avoid damaging the starter motor.
- If your vehicle is equipped with a turbocharger, do not stop the engine immediately after high-speed or uphill driving. First allow the engine to idle to give the turbocharger a chance to cool down.

#### For vehicles equipped with the keyless operation system

- The operation mode can be in any mode to start the engine.
- The starter motor will be turning for up to approximately 15 seconds if the engine switch is released at once. Pressing the engine switch again while the starter motor is still turning will stop the starter motor. The starter motor will be turning for up to approximately 30 seconds while the engine switch is pressed. If the engine does not start, wait for a while and then attempt to start the engine again. Trying repeatedly with the starter motor still turning will damage the starter mechanism.

**⚠ WARNING**

- Never run the engine in a closed or poorly ventilated area any longer than is needed to move your vehicle in or out of the area. Carbon monoxide gases are odourless and can be fatal.

**⚠ CAUTION**

- Never attempt to start the engine by pushing or pulling the vehicle.
- Do not run the engine at high rpm or drive the vehicle at high speed until the engine has had a chance to warm up.
- If your vehicle is equipped with a turbocharger, do not stop the engine immediately after high-speed or uphill driving. First allow the engine to idle to give the turbocharger a chance to cool down.

### Starting the engine

E00625501505

**Except for vehicles equipped with the keyless operation system**

1. Insert the ignition key and fasten the seat belt.
2. Make sure the parking brake is applied.
3. Press and hold the brake pedal down firmly with your right foot.

4. On vehicles equipped with M/T, depress the clutch pedal all the way and place the gearshift lever in the “N” (Neutral) position.  
On vehicles equipped with A/T, make sure the selector lever is in the “P” (PARK) position.

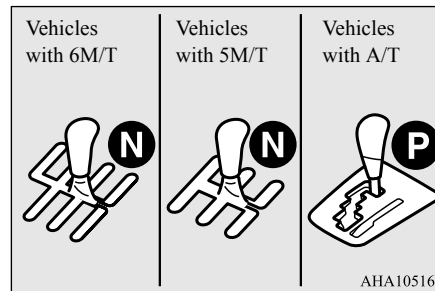

5. Turn the ignition key to the “ON” position.  
The diesel preheat indicator lamp will first illuminate, and then after a short time go out, indicating that preheating is completed.

**📖 NOTE**

- If the engine is cold, the diesel preheat indicator lamp is on for a longer time.

**📖 NOTE**

- When the engine has not been started within about 5 seconds after the diesel preheat indicator lamp went out, return the ignition switch to the “LOCK” position. Then, turn the switch to the “ON” position to preheat the engine again.
- When the engine is warm, the diesel preheat indicator lamp does not come on even if the ignition key is placed in the “ON” position. Start the engine by turning the ignition key right to the “START” position.

6. Turn the ignition key to the “START” position without depressing the accelerator pedal, and release it when the engine starts.

**📖 NOTE**

- Minor noises may be heard on engine start-up. These will disappear as the engine warms up.

**For vehicles equipped with the keyless operation system**

1. Fasten the seat belt.
2. Make sure the parking brake is applied.
3. Press and hold the brake pedal down firmly with your right foot.



## Starting and stopping the engine

### NOTE

- When the engine is not started, it may become hard to depress the brake pedal and the vehicle may not be able to detect the pedal operation. Therefore the engine may not be started. In such a case, depress the brake pedal more firmly than usual.

**6**

4. On vehicles equipped with M/T, depress the clutch pedal all the way and place the gearshift lever in the “N” (Neutral) position. On vehicles equipped with A/T, make sure the selector lever is in the “P” (PARK) position.

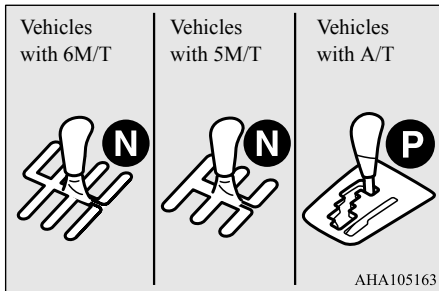

5. Press the engine switch. The diesel preheat indicator lamp will first illuminate, and then after a short time go out, indicating that preheating is completed. The engine will start.

### NOTE

- If the engine is cold, the diesel preheat indicator lamp is on for a longer time.
- Putting the operation mode in ON will also start preheating the engine. When the engine has not been started within about 5 seconds after the diesel preheat indicator lamp went out, put the operation mode in OFF. Then, attempt the engine start procedure to preheat the engine again.
- Minor noises may be heard on engine start-up. These will disappear as the engine warms up.
- When starting the engine, you pressed the engine switch without depressing the clutch pedal, warning display will appear (M/T).

Warning display (color liquid crystal display)



### NOTE

- When starting the engine, the selector lever is in a position other than the “P” (PARK) or the “N” (NEUTRAL) position, or you pressed the engine switch without depressing the brake pedal, warning display will appear. (A/T)

Warning display (color liquid crystal display)



## Stopping the engine

E00620801301

### Except for vehicles equipped with the keyless operation system

- Bring the vehicle to a complete stop.
- Fully engage the parking brake while depressing the brake pedal.
- For vehicles equipped with M/T, turn the ignition switch to the “LOCK” position to stop the engine, and then move the gearshift lever to the 1st (on a uphill) or “R” (Reverse) (on a downhill) position. For vehicles equipped with A/T, place the selector lever in the “P” (PARK) position, and stop the engine.

**For vehicles equipped with the keyless operation system**

**⚠ WARNING**

- Do not operate the engine switch while driving except in an emergency. If the engine is stopped while driving, the brake servomechanism will cease to function and braking efficiency will deteriorate. Also, the power steering system will not function and it will require greater manual effort to operate the steering. This could result in a serious accident.

**📖 NOTE**

- If you have to bring the engine to an emergency stop while driving, press and hold the engine switch for 3 seconds or more, or press it quickly 3 times or more. The engine will stop and the operation mode will go to ACC.
- Do not stop the engine with the selector lever in any position other than the “P” (PARK) position (A/T). If the engine is stopped with the selector lever in any position other than the “P” (PARK) position, the operation mode will go to ACC rather than OFF. Put the operation mode in OFF after placing the selector lever in the “P” (PARK) position.

1. Stop the vehicle.

2. Fully engage the parking brake while depressing the brake pedal.
3. On vehicles with M/T, press the engine switch to stop the engine, move the gear-shift lever to the 1st (on a uphill) or “R” (Reverse) (on a downhill) position. On vehicles with A/T, move the selector lever to the “P” (PARK) position, press the engine switch to stop the engine.

**Fuel injection amount learning process**

E00627901112

To keep exhaust emissions and engine noise low, the engine very occasionally performs a learning process for the fuel injection amount.

The engine sounds slightly different from usual while the learning process is taking place. The change in the engine sound does not indicate a fault.

**If the keyless operation key is not operating properly**

E00632901354

Insert the keyless operation key into the key slot. Starting the engine and changing the operation mode should be now possible.

Remove the keyless operation key from the key slot after starting the engine or changing the operation mode.

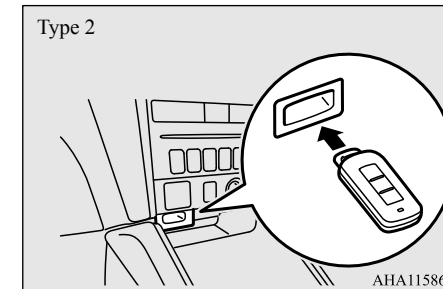
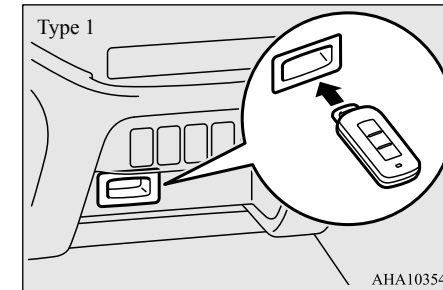

**📖 NOTE**

- Do not insert into the key slot anything other than the keyless operation key. This could cause damage or a malfunction.

## Turbocharger operation\*

6

### NOTE

- Remove the object or additional key from the keyless operation key before inserting the key into the key slot. The vehicle may not be able to receive the registered ID code from the registered key. Therefore, the engine may not start and the operation mode may not change.
- The keyless operation key is fixed, if the key is inserted in the key slot as illustrated. When pulling out the key, pull out in the state.

### Keyless operation key reminder\*

E00633001307

Warning lamp (mono-color liquid crystal display)



Warning display (color liquid crystal display)



If the operation mode is in OFF and the driver's door is opened with the keyless oper-

ation key in the key slot, the warning lamp will blink or warning display will appear for approximately 1 minute, the outer buzzer sounds for approximately 3 seconds and the inner buzzer sounds for approximately 1 minute to remind you to remove the key.

### Turbocharger operation\*

E00611200083

### CAUTION

- Do not run the engine at high speeds (for example, by revving it or by accelerating rapidly) immediately after starting it.
- Do not stop the engine immediately after high-speed or uphill driving. First allow the engine to idle to give the turbocharger a chance to cool down.

### Turbocharger

The turbocharger increases engine power by pushing large amounts of air into the engine's cylinders. The finned parts inside the turbocharger turn at extremely high speeds and are subjected to extremely high temperatures. They are lubricated and cooled by engine oil. If the engine oil is not replaced at the specified intervals, the bearings may seize or emit abnormal noise.

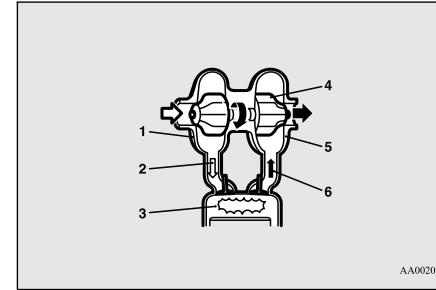

AA0020860

- 1- Air compressor
- 2- Compressed air
- 3- Cylinder
- 4- Turbo fin
- 5- Turbine
- 6- Exhaust gas

### Auto Stop & Go (AS&G) system\*

E00627401188

The Auto Stop & Go (AS&G) system automatically stops and restarts the engine without operating the ignition switch or engine switch when the vehicle is stopped, such as at a traffic light or in a traffic jam, to reduce exhaust gases, increase fuel efficiency.

**CAUTION**

- If the vehicle will be stopped for a long time or if you will leave the vehicle unattended, stop the engine.

**NOTE**

- The accumulated time the engine has been stopped by AS&G system is displayed in the multi information display. Refer to “Auto Stop & Go monitor” on page 5-12.
- If the AS&G system does not operate or it operates less frequently, the battery capacity may have decreased. Have your vehicle inspected by an authorised MITSUBISHI MOTORS dealer.

### Automatically stopping the engine

E00627501554

The AS&G system is automatically activated when the ignition switch is turned to the “ON” position or the operation mode is put in ON.

You can deactivate the system by pressing the “AS&G OFF” switch.

Refer to “To deactivate” on page 6-27.

When the AS&G system will operate, the  indicator display will turn on to inform the driver.

Indicator display



[For vehicles with M/T]

1. Stop the vehicle.
2. While depressing the brake pedal, fully depress the clutch pedal and place the gearshift lever in the “N” (Neutral) position.

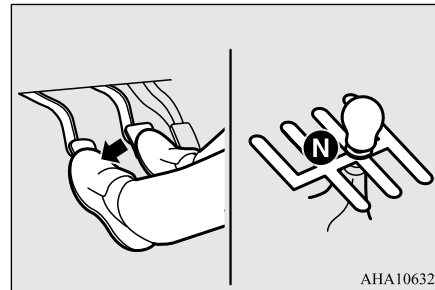

AHA106320

3. Release the clutch pedal. The engine will stop automatically.

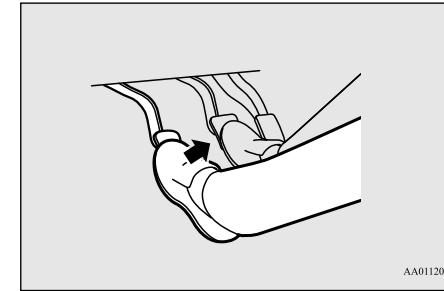

AA0112064

6

[For vehicles with A/T]

1. Stop the vehicle.
2. Depressing the brake pedal. The engine will stop automatically.

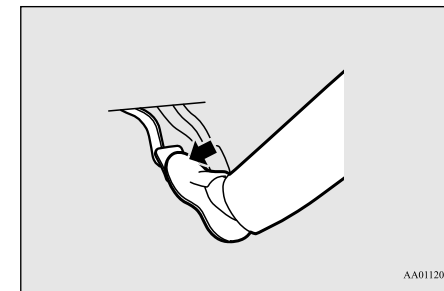

AA0112080

**NOTE**

- When the engine is automatically stopped, changes will occur in the driving operations. Pay careful attention to the following.

## Auto Stop & Go (AS&G) system\*

### NOTE



- The brake booster becomes inoperative and the pedal effort will increase. If the vehicle is moving, press down the brake pedal harder than usual.

### CAUTION



- When the engine is automatically stopped, do not attempt to exit the vehicle. Because the engine restarts automatically when the driver's seat belt is unfastened or the driver's door is opened, an unexpected accident might occur when the vehicle starts moving.
- Observe the following precautions when the engine is stopped automatically. Otherwise, an unexpected accident might occur when the engine restarts automatically.
  - Do not depress the accelerator pedal to race the engine while the vehicle is stopped (regardless of whether the engine is running or stopped).

6

### CAUTION

- On vehicles with M/T, do not move the gearshift lever to a position other than the "N" (Neutral) position. If the gearshift lever is moved to a position other than the "N" (Neutral) position, the  indicator display blinks and the buzzer sounds. If the gearshift lever is returned to the "N" (Neutral) position, the  indicator display stops blinking and the buzzer stops sounding. The engine will not restart if the gearshift lever is in a position other than the "N" (Neutral) position.

### NOTE

- In the following cases, the  indicator display will blink to inform the driver and the engine will not stop automatically.
  - Driver's seat belt is not fastened
  - Driver's door is opened
  - Bonnet is opened
- In the following cases, the  indicator display will turn off and the engine will not stop automatically.
  - After the engine starts, the vehicle speed has not exceeded approximately 5 km/h
  - After the engine start, approximately 30 seconds or more have not elapsed
  - After the engine restarts automatically, the vehicle stops again within 10 seconds
  - Engine coolant temperature is low

### NOTE

- Ambient temperature is low
- When the heater is operated, vehicle indicator temperature is not still hot enough.
- Air conditioning is operating and passenger compartment has not sufficiently cooled
- Demister switch is pressed  
Refer to "Demisting of the windscreen and door windows: For quick demisting" on page 7-13.
- When the air conditioning is operated in AUTO mode where the temperature control is set to the max. hot or the max. cool. (for vehicles with automatic climate control air conditioning)
- Electric power consumption is high, such as when the rear window demister or other electrical components are operating or the blower speed is set to a high setting
- Battery voltage or battery performance is low
- Check engine warning lamp is illuminated or the  indicator display is blinking
- The selector lever is other than in the "D" (DRIVE) position (A/T)
- ASTC operation indicator and ASTC OFF indicator is turn on (A/T)
- ABS warning lamp is turn on
- A/T warning lamp will turn on/warning display will display (A/T)
- On 4WD vehicles, the drive mode-selector in "4H" or "4L" (Easy Select 4WD), "4HLc" or "4LLc" (Super Select 4WD II)

**NOTE**

- The Hill Descent Control is operating (if so equipped)
- In the following cases, the engine will not stop automatically even if the **(A)** indicator display turn on.
  - Push the accelerator pedal
  - Brake booster vacuum pressure is low
  - Brake pedal is not sufficiently depressed (A/T)
  - Operate the steering wheel
  - Parking brake operates (A/T)
  - Parking on steep hill
- Do not rest your foot on the clutch pedal while driving because this will cause detection of clutch pedal switch malfunction and blinking of **(A,OFF)** indicator display, and AS&G system will not operate.
- If the AS&G system operates while the air conditioning is operating, both the engine and the air conditioning compressor will stop. Therefore, only the blower will operate, the windows may start to fog up. If this occurs, press the demister switch to restart the engine.  
Refer to “Demister switch” on page 7-13.
- If the windows become fogged up each time the engine is stopped, we recommend you to deactivate the AS&G system by pressing the “AS&G OFF” switch. Refer to “To deactivate” on page 6-27.

**NOTE**

- If the air conditioning is operating, set the temperature control higher to lengthen the time that the engine is stopped automatically.

### Automatically restarting the engine

E00627601366

On vehicles with M/T, depress the clutch pedal while the gearshift lever is in the “N” (Neutral) position. The **(A)** indicator display turns off and the engine restarts automatically.

On vehicles with A/T, Release the brake pedal. The **(A)** indicator display turns off and the engine restart automatically.

**NOTE**

- On vehicle with M/T, do not move the gearshift lever to a position other than the “N” (Neutral) position or do not release the clutch pedal while the engine is restarting automatically. The starter motor will stop and the engine will not restart automatically.

**NOTE**

- If the engine does not restart automatically or if the engine stalls, the charge warning lamp and check engine warning lamp will illuminate.  
If this occurs,  
[On vehicles with M/T]  
The engine will not restart even if the clutch pedal is depressed again. While depressing the brake pedal, fully depress the clutch pedal and turn the ignition switch to the “START” position or press the engine switch to start the engine.  
[On vehicles with A/T]  
The engine will not restart even if release the brake pedal again. Also, the **(A,OFF)** indicator display blinks, and the buzzer sounds.  
While depressing the brake pedal, move the selector lever to the “P” (PARK) or “N” (NEUTRAL) position and turn the ignition switch to the “START” position or press the engine switch to start the engine. After the engine is started, the buzzer stops.  
But the **(A,OFF)** indicator display is blinking until turning the ignition switch to the “LOCK” position or putting the operation mode in OFF.  
For details, refer to “Starting and stopping the engine” on page 6-18.

6

## Auto Stop & Go (AS&G) system\*

6

### NOTE

- The vehicles with A/T have the function of preventing the unexpected start of the vehicle due to creeping, etc., by temporarily maintain the braking force applied when the engine restarts automatically. This function is deactivated if the selector lever is set into “N” (NEUTRAL) position. While the function is activated, you might hear operation noise from under the vehicle or feel a shock from the brake pedal. This indicates that the function is operating normally. It does not indicate a malfunction.

### CAUTION

- In the following cases, the engine will restart automatically even if the engine was stopped by the AS&G system. Pay careful attention, otherwise an unexpected accident might occur when the engine restarts.
  - Vehicle speed is 3 km/h or higher when coasting down a slope
  - Brake booster vacuum pressure is low because the brake pedal is depressed repeatedly or depressed harder than usual
  - Engine coolant temperature is low
  - When the air conditioning is operated by pressing the air conditioning switch
  - When the preset temperature of the air conditioning is changed significantly

### CAUTION

- When the air conditioning is operated in AUTO mode where the temperature control is set to the max. hot or the max. cool (for vehicles with automatic climate control air conditioning)
- When the air conditioning is ON, the passenger compartment temperature rises and the air conditioning compressor operates to lower the temperature
- Demister switch is pressed Refer to “For quick demisting” on page 7-13
- Electric power consumption is high, such as when the rear window demister or other electrical components are operating or the blower speed is set to a high setting
- Battery voltage or battery performance is low
- Move the selector lever to the “R” (REVERSE) position (A/T)
- Move the selector lever from the “N” (NEUTRAL) to “D” (DRIVE) position (A/T)
- Operate the steering wheel
- Driver’s seat belt is unfastened
- Driver’s door is opened
- Press the Hill Descent Control switch. (if so equipped)

### NOTE

- In the following cases, the engine will not restart automatically.
  - On vehicles with M/T, while the engine is stopped automatically, “AS&G OFF” switch is pressed to deactivate the “AS&G” system.
  - Bonnet is opened.
- When the engine restarts automatically, decrease in audio volume may temporarily be experienced. This does not indicate a malfunction.
- While the engine is stopped automatically, the air volume change of the air conditioning may temporarily be experienced. This does not indicate a malfunction.
- On vehicles with A/T, while the engine is stopped automatically, if the selector lever is moved to the “P” (PARK) position quickly with the brake pedal firmly depressed, the engine does not restart automatically even if you release the brake pedal. If this occurs, the  indicator display will blink to inform the driver. If you want to restart the engine, depress the brake pedal again. If you want to put the operation mode in OFF, press the engine switch without depressing the brake pedal. (Vehicles equipped with the keyless operation system)

## To deactivate

E00627701266

The AS&G system is automatically activated when the ignition switch is turned to the “ON” position or the operation mode put in ON. You can deactivate the system by pressing the “AS&G OFF” switch.

When the AS&G system is deactivated, the **(A) OFF** indicator display will be turned on.

To reactivate the AS&G system, press the “AS&G OFF” switch; the indicator will turn off.

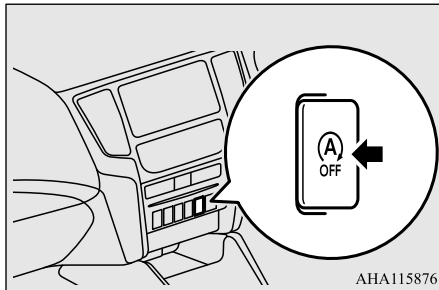

AHA115876

AS&G OFF indicator display



## NOTE

- This display will also turn on for a few seconds when the ignition switch is turned to the “ON” position or the operation mode put in ON.

## If the **(A) OFF** indicator display blinks while driving

E00627801137

If the **(A) OFF** indicator display blinks, the AS&G system is malfunctioning and will not operate.

We recommend you to consult an authorised MITSUBISHI MOTORS dealer.

## Manual transmission\*

E00602002643

The shift pattern is shown on the gearshift lever knob. Press the clutch pedal all the way down while shifting gears. To start off, press the clutch pedal all the way down and shift into 1st or “R” (Reverse) position, operating the gearshift lever slowly.

Then gradually release the clutch pedal while depressing the accelerator pedal.

## CAUTION

- Do not put the gearshift lever into the reverse position while the vehicle is moving forward. Doing so could damage the transmission.
- Do not rest your foot on the clutch pedal while driving as this will cause premature clutch wear or damage.
- Do not coast in the “N” (Neutral) position.
- Do not use the gearshift lever as a hand rest, because this can result in premature wear of the transmission shift forks.
- Quick or slight clutch engagement made while the engine is running at high speed will cause damage to the clutch and transmission because the tractive force is very great.

6

## NOTE

- During cold weather, shifting may be difficult until the transmission lubricant has warmed up. This is normal and not harmful to the transmission.
- If it is hard to shift into 1st, depress the clutch pedal again; the shift will then be easier to make.
- On vehicles with 6 M/T, in case of hot weather condition or long time cruising with high speed, a speed limitation function may work to restrict the oil temperature rising of the manual transmission. After the oil temperature drops to the appropriate level, the speed limitation function is cancelled.



### Moving the gearshift lever to the “R” (Reverse) position

E00615401396

#### Vehicles with 5 M/T

To shift into the “R” (Reverse) position from 5th gear, move the gearshift lever to the “N” (Neutral) position, and then move it to the “R” (Reverse) position.

**6**

#### Vehicles with 6 M/T

Depress and hold the gearshift lever to the “R” (Reverse) position.

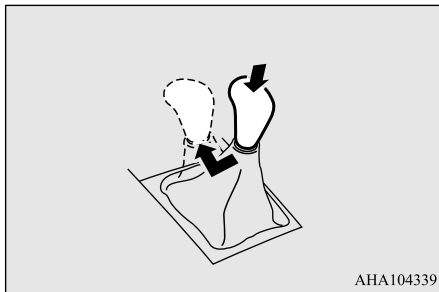

AHA104339

### CAUTION

- Do not depress the gearshift lever when moving it to any position other than the “R” (Reverse) position. If you always depress the gearshift lever when moving it, you could unintentionally move the gearshift lever to the “R” (Reverse) position and cause an accident and/or a transmission fault.

### Possible driving speed

E00610803243

Avoid shifting down at high speed, as this may cause excessive engine speed (the tachometer needle into the red zone) and damage the engine.

#### 4D56

Shift point	Speed limit
1st gear	30 km/h
2nd gear	60 km/h
3rd gear	100 km/h
4th gear	145 km/h

Use 5th gear whenever vehicle speed allows, for maximum fuel economy.

#### 4N15

##### ■ 2WD models

Shift point	Speed limit
1st gear	30 km/h
2nd gear	60 km/h
3rd gear	100 km/h
4th gear	145 km/h
5th gear	175 km/h

Use 6th gear whenever vehicle speed allows, for maximum fuel economy.

##### ■ Vehicles with Easy Select 4WD

Shift point	Speed limit	
	2H,4H	4L
1st gear	30 km/h	10 km/h
2nd gear	60 km/h	20 km/h
3rd gear	100 km/h	35 km/h
4th gear	140 km/h	55 km/h
5th gear	165 km/h	70 km/h

Use 6th gear whenever vehicle speed allows, for maximum fuel economy.

■ Vehicles with Super Select 4WD II

Shift point	Speed limit	
	2H,4H,4HLc	4LLc
1st gear	35 km/h	10 km/h
2nd gear	65 km/h	25 km/h
3rd gear	105 km/h	40 km/h
4th gear	150 km/h	55 km/h
5th gear	175 km/h	75 km/h

Use 6th gear whenever vehicle speed allows, for maximum fuel economy.

**Automatic transmission Sports Mode 6A/T\***

E00603202189

**NOTE**

- During running-in period or immediately after reconnection of the battery cable, there may be a case where gear shifts are not made smoothly. This does not indicate a faulty transmission. Gear shifts will become smooth after the transmission has been shifted several times by the electronic control system.

**Selector lever operation**

E00603302379

The transmission has 6 forward gears and 1 reverse gear. The individual gears are selected automatically, depending on the speed of the vehicle and the position of the accelerator pedal. The selector lever (A) has 2 gates; the main gate (B) and the manual gate (C).

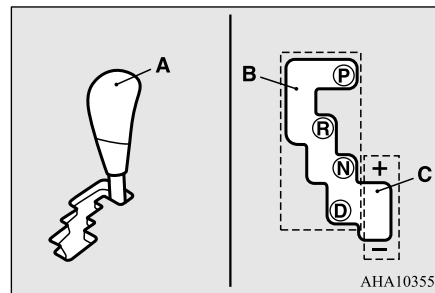

AHA103550

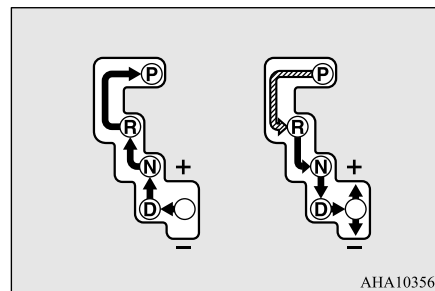

AHA103563

- While depressing the brake pedal, move the selector lever through the gate.
- Move the selector lever through the gate.

**WARNING**

- Always depress the brake pedal when shifting the selector lever into a gear from the "P" (PARK) or "N" (NEUTRAL) position. Never put your foot on the accelerator pedal while shifting the selector lever from the "P" (PARK) or "N" (NEUTRAL) position.

**NOTE**

- To avoid erroneous operation, move the selector lever firmly into each position and briefly hold it there. Always check the position shown by the selector lever position display after moving the selector lever.
- If the brake pedal is not depressed and held, the shift-lock device activates to prevent the selector lever from being moved from the "P" (PARK) position.

### When the selector lever cannot be shifted from the “P” (PARK) position

E00629101365

When the selector lever cannot be shifted from the “P” (PARK) position to another position while the brake pedal is pressed and held down with the ignition switch at the “ON” position or the operation mode in ON, the battery may be flat or the shift-lock mechanism may be malfunctioning. Immediately have your vehicle checked by an authorised MITSUBISHI MOTORS dealer.

If you need to move the vehicle, shift the selector lever as follows.

1. Make sure the parking brake is fully applied.
2. Stop the engine if it is running.
3. Depress the brake pedal with the right foot.
4. Insert a straight blade (or minus) screwdriver in the shift-lock release hole (A). Shift the selector lever to the “N” (NEUTRAL) position while pressing the straight blade (or minus) screwdriver down.

6

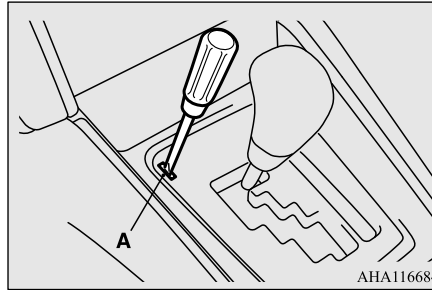

### Selector lever position display

E00603502153

When the ignition switch is turned to the “ON” position or the operation mode is put in ON, the position of the selector lever is indicated in the multi information display.

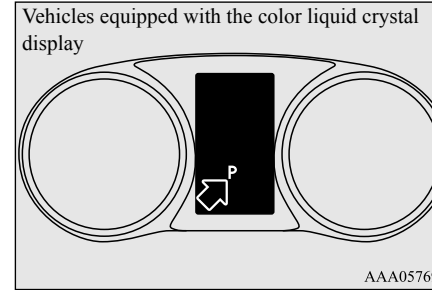
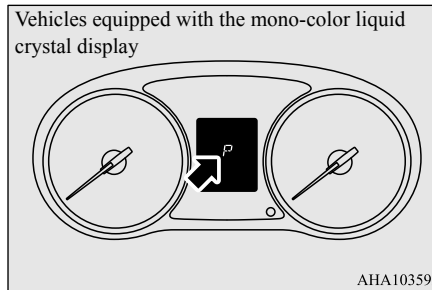

### Selector lever positions

E00603801973

#### “P” PARK

This position locks the transmission to prevent the vehicle from moving. The engine can be started in this position.

#### “R” REVERSE

This position is to back up.

#### ⚠ CAUTION

- Never shift into the “P” (PARK) or “R” (REVERSE) position while the vehicle is in motion to avoid a transmission damage.

## “N” NEUTRAL

At this position the transmission is disengaged. It is the same as the neutral position on a manual transmission, and should only be used when the vehicle is stationary for an extended length of time during driving, such as in a traffic jam.

### ⚠ WARNING

- Never move the selector lever to the “N” (NEUTRAL) position while driving. A serious accident could occur since you could accidentally move the lever into the “P” (PARK) or “R” (REVERSE) position or you will lose engine braking.
- On a gradient, the engine should be started in the “P” (PARK) position, not in the “N” (NEUTRAL) position.
- To prevent rolling, always keep your foot on the brake pedal when the vehicle is in “N” (NEUTRAL) position, or when shifting into or out of “N” (NEUTRAL) position.

## “D” DRIVE

This position is used for most city and highway driving. The transmission will automatically change its gear depending on road and driving conditions.

### ⚠ CAUTION

- To prevent transmission damage, never shift into the “D” (DRIVE) position from the “R” (REVERSE) position while the vehicle is in motion.

## Sport mode

E00603902838

Whether the vehicle is stationary or in motion, sports mode is selected by gently pushing the selector lever from the “D” (DRIVE) position into the manual gate (A).

To return to “D” range operation, gently push the selector lever back into the main gate (B).

In sports mode, gear shifts can be made rapidly simply by moving the selector lever backward and forward. For vehicles equipped with the shift paddles, shift paddles at the steering wheel can also be used to perform the gearshift. In contrast to a manual transmission, the sports mode allows gear shifts with the accelerator pedal depressed.

### 📖 NOTE

- If your vehicle is equipped with the shift paddles, you can shift into sports mode with shift paddles when the selector lever is in the main gate as well. Also, you can return to the “D” range operation in any of following ways.

When returning to “D” range operation, the selector lever position display will change to “D” (DRIVE) position.

- Pull the + (SHIFT UP) side shift paddle forward (toward the driver) for over 2 seconds.
- Stop the vehicle.
- Push the selector lever from the “D” (DRIVE) position into the manual gate (A) and push the selector lever back into the main gate (B).

6

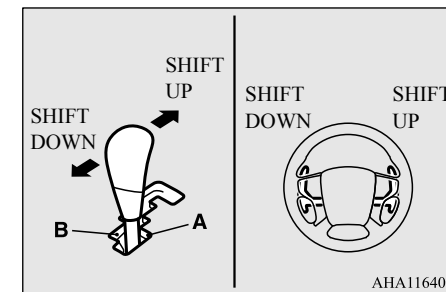

## Automatic transmission Sports Mode 6A/T\*

### + (SHIFT UP)

The transmission shifts up by one gear with each operation.

### - (SHIFT DOWN)

The transmission shifts down by one gear with each operation.

6

### ⚠ CAUTION

- In sports mode, the driver must execute upward shifts in accordance with prevailing road conditions, taking care to keep the engine speed below the red zone.
- Repeated continuous operation of the selector lever or the shift paddles will continuously switch shift position.
- For vehicles equipped with the shift paddles, do not use the left- and right-hand shift paddles at the same time. Doing so could cause a shift of gear ratio that you do not expect.

### 📖 NOTE

- Only the 6 forward gears can be selected. To reverse or park the vehicle, move the selector lever to the “R” (REVERSE) or “P” (PARK) position as required.

### 📖 NOTE

- To maintain good running performance, the transmission may refuse to perform an upshift when the selector lever or the shift paddles are operated to the “+ (SHIFT UP)” position at certain vehicle speeds. Also, to prevent over-revving of the engine, the transmission may refuse to perform a downshift when the selector lever or the shift paddles are operated to the “— (SHIFT DOWN)” position at certain vehicle speeds. When this happens, a buzzer sounds to indicate that a downshift is not going to take place.
- Downward shifts are made automatically when the vehicle slows down. When the vehicle stops, 1st gear is automatically selected.
- When driving away on a slippery road, push the selector lever forward into the “+ (SHIFT UP)” position. This causes the transmission to shift into the 2nd gear which is better for smooth driving away on a slippery road. Push the selector lever to the “— (SHIFT DOWN)” side to shift back to the 1st gear.

### Sports mode indicator

E00612301756

In sports mode, the currently selected position is indicated by the indicator (A) shown on the instrument panel.

Vehicles equipped with the mono-color liquid crystal display

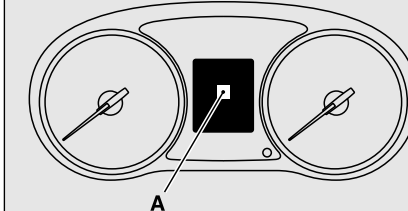

AHA103619

Vehicles equipped with the color liquid crystal display

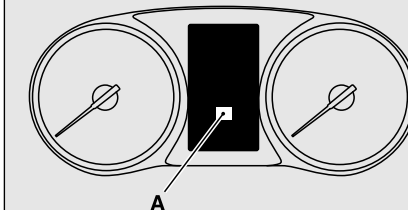

AHA108337

### When a malfunction occurs in the A/T

E00615101667

### Vehicles equipped with the mon-color liquid crystal display

E00660800029

#### ■ When the selector lever position display blinks

E00660900059

When the selector lever position display blinks while you are driving, there could be a malfunction in the A/T system.

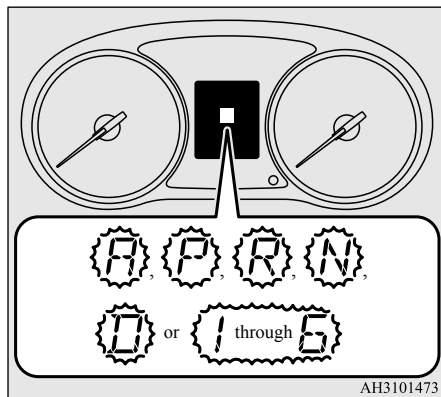

AH3101473

### NOTE

- “A” indicator does blink only the condition that the A/T positional switch is broken. It does not indicate in normal driving condition.

### CAUTION

- If the selector lever position display blinks while you are driving, it is likely that a safety device is operating because of a malfunction in the A/T. Have the vehicle inspected by an authorised MITSUBISHI MOTORS dealer immediately.

#### ■ When the A/T fluid temperature warning lamp comes on

E00661000028

The A/T fluid temperature warning lamp comes on and a buzzer may sound, when the A/T fluid temperature becomes abnormally high. Normally the warning lamp comes on when the ignition switch is turned to the “ON” position or the operation mode is put in ON, and then will go off after a few seconds.

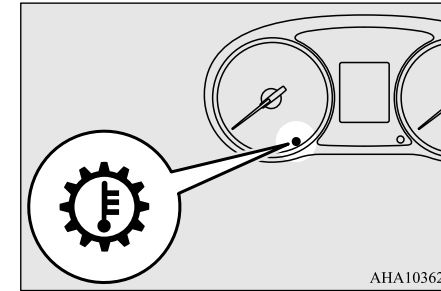

AHA103622

### CAUTION

- If the lamp comes on, reduce the engine speed and stop the vehicle in a safe area. Then set the selector lever to “P” (PARK) position and idle the engine until the warning lamp goes off. When the warning lamp goes off, resume normal driving. If the warning lamp does not go off, please have your vehicle inspected by an authorised MITSUBISHI MOTORS dealer.

### Vehicles equipped with the color liquid crystal display

E00661100120

There could be a system malfunction if the warning display or the warning display is displayed on the information screen in the multi information display.

6



6

**NOTE**

- The buzzer may sound at the time of the warning display appears.
- The selector lever position indicator blinks at the time of the warning display appears.
- The “A” indicator on the selector lever position display will only blink if there is a problem with the A/T position switch. It is not seen during normal driving.

**CAUTION**

- If malfunction occurs in the A/T while driving, the warning display or the warning display appears on the information screen in the multi information display. In this case, immediately park your vehicle in a safe place and follow these procedures:

When warning display is showing  
The A/T fluid is overheating. The engine control may activate to lower the A/T fluid temperature, causing the engine revolutions and vehicle speed to decrease, or the gear shift timing may change by activating the A/T control. In this case, take one of the following procedures.

- Slow down your vehicle.

**CAUTION**

- Stop your vehicle in a safe place, put the selector lever in the “P” (PARK) position, and open the bonnet with the engine running to allow the engine to cool down.

After a while, confirm that the warning display is no longer showing. It is safe to continue driving if the display is no longer showing. If the warning display remains or appears frequently, have your vehicle inspected by an authorised MITSUBISHI MOTORS dealer.

When warning display is showing  
It may be that there is something unusual happening in the A/T, causing a safety device to activate. Have your vehicle inspected by an authorised MITSUBISHI MOTORS dealer immediately.

**Operation of the A/T**

E00604201903

**CAUTION**

- Before selecting a gear with the engine running and the vehicle stationary, fully depress the brake pedal to prevent the vehicle from creeping.

The vehicle will begin to move as soon as the gear is engaged, especially when the engine speed is high, at fast idle or with the air conditioning operating, the brakes should only be released when you are ready to drive away.

**CAUTION**

- Depress the brake pedal with the right foot at all times. Using the left foot could cause driver movement delay in case of an emergency.
- To prevent sudden acceleration, never race the engine when shifting from the “P” (PARK) or “N” (NEUTRAL) position.
- Operating the accelerator pedal while the other foot is resting on the brake pedal will affect braking efficiency and may cause premature wear of brake pads.
- Use the selector lever in the correct shift position in accordance with driving conditions. Never coast downhill backward with the selector lever in the {“D” (DRIVE) or sports mode} or coast forward with the selector lever in the “R” (REVERSE) position. The engine may stop and the unexpected increase in brake pedal effort and steering wheel weight could lead to an accident.
- Do not race the engine with brake pedal pressed when the vehicle is stationary. This can damage the A/T. Also, when you depress the accelerator pedal while holding down the brake pedal with the selector lever in the “P” (PARK), “N” (NEUTRAL) or “D” (DRIVE) position, the engine revolutions may not rise as high as when performing the same operation with the selector lever in the “N” (NEUTRAL) position.

**Passing acceleration**

E00604501401

To gain extra acceleration in “D” (DRIVE) position, push the accelerator to the floor. The A/T will automatically downshift.

**NOTE**

- In sports mode, downshifts do not take place when the accelerator is depressed all the way to the floor.

**Waiting**

E00604601428

For short waiting periods, such as at traffic signals the vehicle can be left in gear and held stationary with the service brake.

For longer waiting periods with the engine running, place the selector lever in the “N” (NEUTRAL) position and apply the parking brake, while holding the vehicle stationary with the service brake.

**CAUTION**

- Never hold the vehicle stationary on a hill using the accelerator pedal (without using the brake pedal). Always apply the parking brake and/or service brakes.

**Parking**

E00604701360

To park the vehicle, first bring it to a complete stop, fully engage the parking brake, and then move the selector lever to the “P” (PARK) position.

If you are going to leave the vehicle unattended, always switch off the engine and carry the key.

**NOTE**

- On a slope, be sure to apply the parking brake before moving the selector lever to the “P” (PARK) position. If you move the selector lever to the “P” (PARK) position before applying the parking brake, it may be difficult to disengage the selector lever from the “P” (PARK) position when next you drive the vehicle, requiring application of a strong force to the selector lever to move from the “P” (PARK) position.

**When the A/T makes no speed change**

E00604802052

If the transmission does not change speeds while driving, or your vehicle does not pick up enough speed when starting on an uphill slope, it may be that there is something unusual happening in the transmission, causing a safety device to activate. Have your vehicle

checked at an authorised MITSUBISHI MOTORS dealer immediately.

**Easy Select 4WD\***

E00614701347

Shifting to rear-wheel drive or 4-wheel drive can be made by operating the drive mode-selector (A). Set the drive mode-selector to an appropriate position according to the road surface conditions. The Drive mode indicator display and the 2WD/4WD operation indicator lamp/display indicate the drive mode-selector setting state. Refer to “Indicator lamp/display” on page 6-39.

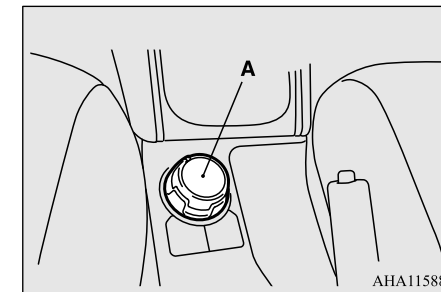







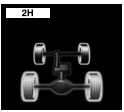

**Drive mode-selector position, drive mode indicator display, 2WD/4WD operation indicator lamp/display and low-range indicator lamp**

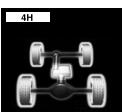
E00641100111

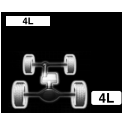
**6**

Drive mode-selector position		Indicator lamp/display		Driving conditions
		Mono-color liquid crystal display	Color liquid crystal display	
2H	Rear-wheel drive			When driving on dry paved road.
4H	4-wheel drive			When driving on rough, sand or snow covered roads.
4L	Low range 4-wheel drive			When driving up or down steep hills, on rough or muddy roads (especially when increased torque is required).

 : Illuminate

 : Remain off

**⚠ CAUTION**

- The “4L” range gives maximum torque for low-speed driving on steep slopes, as well as sandy, muddy, and other difficult surfaces. On vehicles with A/T, do not exceed speeds of approximately 70 km/h in “4L” range.
- Do not drive your vehicle in the “4H” or “4L” on dry paved roads and highways. Doing so may result in excessive tyre wear, increased fuel consumption, and possible noise generation. It may also increase the differential oil temperature, which may damage the drive system. Further, the drive train will be subjected to excessive loading, resulting in oil leakage, component seizure, or other serious problems. On dry paved roads and highways, drive the vehicle in “2H” only.

**Drive mode-selector operation**

E00641200079

The drive mode is shown on the drive mode selector.

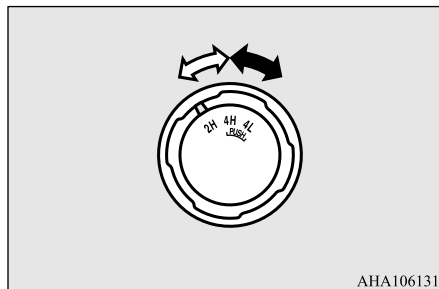

AHA106131

- ⇨: Turn the drive mode-selector
- ➡: Turn the drive mode-selector while holding it down

The drive mode-selector should be positioned in accordance with the following operating conditions:

Easy Select 4WD\*

6

To shift from	To	Procedure	
		Vehicles with M/T	Vehicles with A/T
2H	4H	The drive mode-selector can be operated while the vehicle is either moving or stationary. When the vehicle is not in motion, shift the gearshift lever to the “N” (Neutral) position before operating the drive mode-selector.	The drive mode-selector can be operated while the vehicle is either moving or stationary. When the vehicle is not in motion, shift the selector lever to the “N” (NEUTRAL) position before operating the drive mode-selector.
4H	2H	When the vehicle is moving, and only while it can be steered straight ahead, release the accelerator pedal before operating the drive mode-selector.	When the vehicle is moving, and only while it can be steered straight ahead, shift the selector lever to the “D” (DRIVE) position, and release the accelerator pedal before operating the drive mode-selector.
4H	4L	Stop the vehicle, depress the clutch pedal to the floor and operate the drive mode-selector. Keep depressing the clutch pedal while 2WD/4WD operation indicator lamp/display continues to blink.	Stop the vehicle, shift the selector lever to the “N” (NEUTRAL) position, and operate the drive mode-selector. If operation is made with the selector lever placed in any other position than “N” (NEUTRAL) position, a gear noise may be generated, with a possible failure to shift into a proper gear.
4L	4H		

 **NOTE**

- Setting of the drive mode-selector between “2H” ↔ “4H” should only be done at speeds below 100 km/h.
- During driving, never attempt to shift from “4H” to “4L”.
- When shifting from “2H” to “4H” in cold weather while the vehicle is in motion, the transfer gear may make some noise. In cold weather, try to shift the gear while the vehicle is stopped.
- When shifting between “4H” and “4L”, the transfer gear may make some noise.
- When the drive mode-selector is set between “2H” ↔ “4H” while the vehicle is stopped, the 2WD/4WD operation indicator lamp/display blinks while the selection is in process.  
Drive slowly and normally after confirming that the lamp/display is illuminated. (Refer to “Indicator lamp/display” on page 6-39.)
- When the drive mode-selector is set between “2H” ↔ “4H” while the cruise control is activated, the transfer gear may make some noise.
- When the drive mode-selector is set between “4H” ↔ “4L” in cold weather, its selection may not complete. Return the drive mode-selector to its previous position. After the engine is warmed up, make the range selection again.

**CAUTION**

- Do not operate the drive mode-selector while the rear wheels of the vehicle are slipping on snow or ice.

**Indicator lamp/display**

E00693900020

Vehicles equipped with the mono-color liquid crystal display, refer to “2WD/4WD operation indicator lamp and low-range indicator lamp” on page 6-39.

Vehicles equipped with the color liquid crystal display, refer to “Drive mode indicator display and 2WD/4WD operation indicator display” on page 6-41.

**2WD/4WD operation indicator lamp and low-range indicator lamp**

E00694000086

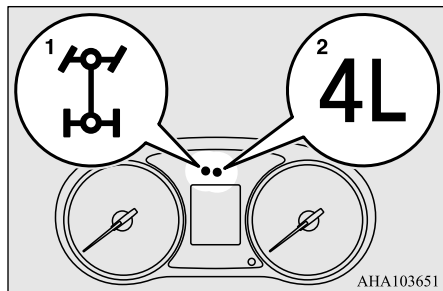

When the ignition switch is in the “ON” position or the operation mode is put in ON, the 2WD/4WD operation indicator lamp (1) and the low-range indicator lamp (2) shows the shifting condition. The 2WD/4WD operation indicator lamp comes on at each drive mode-selector position as follows:

■ “2H” ↔ “4H”

Drive mode-selector position	Indicator lamp
2H	
Drive mode switching in progress	
4H	

- : Blink
- : Illuminate
- : Remain off







**NOTE**

- When the drive mode-selector is set between 2H ↔ 4H, the 2WD/4WD operation indicator lamp blinks while the selection is in process. Take the following precautions when the indicator lamp is blinking.
  - Keep the steering wheel in the straight ahead position while making range selections. If you attempt to drive forward with the steering wheel turned, gear rattling or shock may occur and cornering may not be smooth and the desired range may not actually be selected.
- When the drive mode-selector is set between “2H” ↔ “4H” while the vehicle is stopped, the 2WD/4WD operation indicator lamp blinks while the selection is in process. Drive slowly and normally after confirming that the lamp is switched.
- If the 2WD/4WD operation indicator lamp continues blinking after a “2H” ↔ “4H” selection has been made with the vehicle moving, hold the steering wheel in the straight ahead position and slowly depress the accelerator pedal several times.

Easy Select 4WD\*

■ “4H” ↔ “4L”

6

Drive mode-selector position	Indicator lamp	
4H	 ↓	 ↑
Drive mode switching in progress	 ↓	 and 4L ↑
4L	 and 4L	 and 4L

 : Blink

 : Illuminate

 : Remain off

 **NOTE**

- The 2WD/4WD operation indicator lamp will blink during shifting process from “4H” to “4L” or vice versa, as the transfer passes through the neutral position. Be sure to operate the drive mode-selector until the 2WD/4WD operation indicator lamp illuminates again.
- When parking, apply the parking brake before stopping the engine and make sure that the 2WD/4WD operation indicator is not blinking during shifting process between “4H” ↔ “4L”. Otherwise, the vehicle could unexpectedly move even if the A/T is in the “P” (PARK) position.
- If, after a “4H” ↔ “4L” selection has been made, the 2WD/4WD operation indicator continues blinking and the desired range is not actually selected, return the drive mode-selector to its previous position. Place the steering wheel in the straight ahead position, drive the vehicle forward, and release the accelerator pedal. Next, hold down the clutch pedal (with M/T) or place the selector lever in the “N” (NEUTRAL) position (with A/T) and make the range selection again.

 **NOTE**

- If the 2WD/4WD operation indicator lamp blinks when you attempt to make a “4H” ↔ “4L” selection, cannot be made. Stop the vehicle and release the accelerator pedal. Next, hold down the clutch pedal (with M/T) or place the selector lever in the “N” (NEUTRAL) position (with A/T) and make the range selection again.
- The active stability control function is suspended while “4L” is selected.  indicator lamp is illuminated while these functions are suspended. It does not indicate a problem. When “2H” or “4H” is selected, this lamp goes out and function again. Refer to “ASTC indicator lamp or ASTC OFF indicator lamp” on page 6-74.

 **CAUTION**

- If a problem is detected in the transfer system, a safety device will activate. The 2WD/4WD operation indicator blinks (twice per second), and transfer shifting will become impossible. Park your vehicle in a safe place, turn off the engine for a few moments. Restart the engine. The lamp should resume normal operation. If the lamp continue to blink, have the vehicle checked by an authorised MITSUBISHI MOTORS dealer as soon as possible.

### Drive mode indicator display and 2WD/4WD operation indicator display

E00694100087

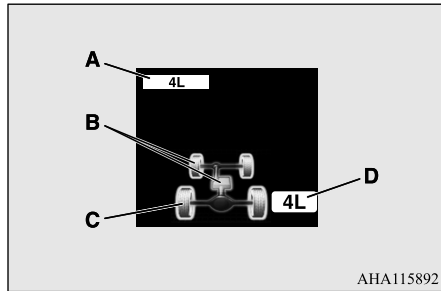

- A: Drive mode indicator display
- B: Front wheel indicator display
- C: Rear wheel indicator display
- D: Low-range indicator display

When the ignition switch is in the “ON” position or the operation mode is put in ON, drive mode indicator display (A) and 2WD/4WD operation indicator display (B, C, D) shows the shifting condition. The drive mode indicator display and 2WD/4WD operation indicator display comes on at each drive mode-selector position as follows:

#### ■ “2H” ↔ “4H”

Drive mode-selector position	Indicator display
2H	
Drive mode switching in progress	
4H	

: Blink (Drive mode indicator display also blinks)

: Illuminate

: Remain off

#### ■ “4H” ↔ “4L”

Drive mode-selector position	Indicator display	
4H		
Drive mode switching in progress		
4L		

: Blink (Drive mode indicator display also blinks)

: Illuminate

: Remain off

6

## Super Select 4WD II\*

6

### NOTE

- When the drive mode-selector is set between “2H” ↔ “4H”, the front wheel indicator display blinks while the selection is in process. Take the following precautions when the indicator display is blinking.
  - Keep the steering wheel in the straight ahead position while making range selections. If you attempt to drive forward with the steering wheel turned, gear rattling or shock may occur and cornering may not be smooth and the desired range may not actually be selected.
- When the drive mode-selector is set between “2H” ↔ “4H”, while the vehicle is stopped, the front wheel indicator display blinks while the selection is in process. Drive slowly and normally after confirming that the display is switched.
- If the front wheel indicator display blinking after a “2H” ↔ “4H” selection has been made with the vehicle moving, hold the steering wheel in the straight ahead position and slowly depress the accelerator pedal several times.
- The front and the rear wheel displays will blink during shifting process from “4H” to “4L” or vice versa, as the transfer passes through the neutral position. Be sure to operate the drive mode-selector until the front and the rear wheel displays illuminate again.

### NOTE

- If, after a “4H” ↔ “4L” selection has been made, front and the rear wheel displays continue blinking and the desired range is not actually selected, return the drive mode-selector to its previous position. Place the steering wheel in the straight ahead position, drive the vehicle forward, and release the accelerator pedal. Next, hold down the clutch pedal, depress and hold the brake pedal and make the range selection again.
- If the front and the rear wheel displays blink when you attempt to make a “4H” ↔ “4L” selection, a “4H” ↔ “4L” selection cannot be made. Stop the vehicle and release the accelerator pedal. Next, hold down the clutch pedal, depress and hold the brake pedal and make the range selection again.
- If the clutch pedal is released during shifting process between “4H ↔ 4L”, the warning display will appear and the shifting process will be stopped (M/T).



### NOTE

- The active stability control function is suspended while “4L” is selected.  indicator lamp is illuminated while these functions are suspended. It does not indicate a problem. When “2H” or “4H” is selected, this lamp goes out and function again. Refer to “ASTC indicator lamp or ASTC OFF indicator lamp” on page 6-74.

### CAUTION

- If the warning display is displayed on the information screen in the multi information display, a problem has occurred with the Easy Select 4WD and the safety device has activated. If this happens, please contact your nearest authorised MITSUBISHI MOTORS dealer for inspection as soon as possible.



## Super Select 4WD II\*

E00605701530

Shifting to rear-wheel drive or 4-wheel drive can be made by operating the drive mode-selector (A). Set the drive mode-selector to an

appropriate position according to the road surface conditions. The Drive mode indicator display and the 2WD/4WD operation indicator display indicate the drive mode-selector setting state. Refer to “Drive mode indicator display and 2WD/4WD operation indicator display” on page 6-46.

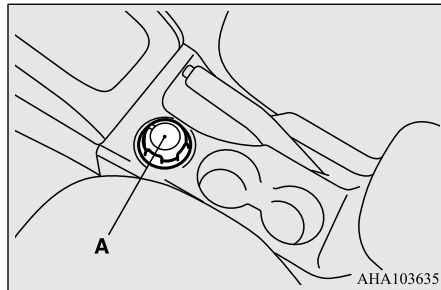

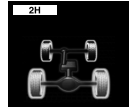
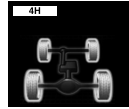

### Drive mode-selector position, drive mode indicator display and 2WD/4WD operation indicator display

E00605801632

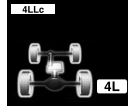
Drive mode-selector position		Drive mode indicator display and 2WD/4WD operation indicator display	Driving conditions
2H	Rear-wheel drive		When driving on dry paved road.
4H	Full-time 4-wheel drive		The basic position for Super Select 4WD II. When driving on dry paved or slippery roads.

Drive mode-selector position		Drive mode indicator display and 2WD/4WD operation indicator display	Driving conditions
4HLc	Centre differential lock engaged 4-wheel drive		When driving on rough, sand or snow covered roads.
4LLc	Low range centre differential lock engaged 4-wheel drive		When driving up or down steep hills, on rough or muddy roads (especially when increased torque is required).

 : Illuminate  
 : Remain off

**6**



Super Select 4WD II\*

6

**CAUTION**

- The “4LLc” range gives maximum torque for low-speed driving on steep slopes, as well as sandy, muddy, and other difficult surfaces. On vehicles with A/T, do not exceed speeds of approximately 70 km/h in “4LLc” range.
- Do not drive your vehicle in the “4HLc” or “4LLc” position on dry paved roads and highways. Doing so may result in excessive tyre wear, increased fuel consumption, and possible noise generation. It may also increase the differential oil temperature, which may damage the drive system. Further, the drive train will be subjected to excessive loading, resulting in oil leakage, component seizure, or other serious problems. On dry paved roads and highways, drive the vehicle in “2H” or “4H” only.

**Drive mode-selector operation**

E00605901620

The drive mode is shown on the drive mode-selector knob.

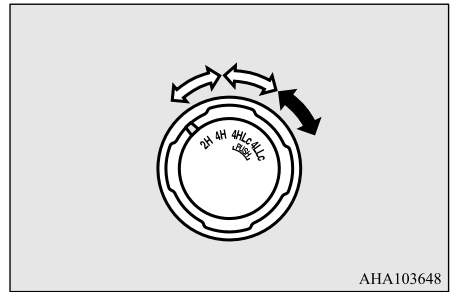

AHA103648

- ⇨: Turn the drive mode-selector
- ➔: Turn the drive mode-selector while holding it down

The drive mode-selector should be positioned in accordance with the following operating conditions:

To shift from	To	Procedure	
		Vehicles with M/T	Vehicles with A/T
2H	4H	The drive mode-selector can be operated while the vehicle is either moving or stationary. When the vehicle is not in motion, shift the gearshift lever to the “N” (Neutral) position before operating the drive mode-selector. When the vehicle is moving, and only while it can be steered straight ahead, release the accelerator pedal before operating the drive mode-selector.	The drive mode-selector can be operated while the vehicle is either moving or stationary. When the vehicle is not in motion, shift the selector lever to the “N” (NEUTRAL) position before operating the drive mode-selector.
4H	2H or 4HLc		When the vehicle is moving, and only while it can be steered straight ahead, shift the selector lever to the “D” (DRIVE) position, and release the accelerator pedal before operating the drive mode-selector.
4HLc	4H		

To shift from	To	Procedure	
		Vehicles with M/T	Vehicles with A/T
4HLc	4LLc	Stop the vehicle, depress the clutch pedal to the floor and operate the drive mode-selector. Keep depressing the clutch pedal while the 2WD/4WD operation indicator display continues to blink.	Stop the vehicle, shift the selector lever to the “N” (NEUTRAL) position, and operate the drive mode-selector. If operation is made with the selector lever placed in any other position than “N” (NEUTRAL) position, a gear noise may be generated, with a possible failure to shift into a proper gear.
4LLc	4HLc		

**NOTE**

- Setting of the drive mode-selector between “2H”, “4H” and “4HLc” should only be done at speeds below 100 km/h.
- During driving, never attempt to shift from “4HLc” to “4LLc”.
- When shifting between “2H”, “4H” and “4HLc” in cold weather while the vehicle is in motion, the transfer gear may make some noise. In cold weather, try to shift the gear while the vehicle is stopped.
- When shifting between “4LLc” and “4HLc”, the transfer gear may make some noise.
- When the drive mode-selector is set between “2H”, “4H” and “4HLc” while the vehicle is stopped, the 2WD/4WD operation indicator display blinks while the selection is in process. Drive slowly and normally after confirming that the display is illuminated. (Refer to “Drive mode indicator display and 2WD/4WD operation indicator display” on page 6-46.)
- When the drive mode-selector is set between “2H”, “4H” and “4HLc” while the cruise control is activated, the transfer gear may make some noise.
- When the drive mode-selector is set between “4HLc” ↔ “4LLc” in cold weather, its selection may not complete. Return the drive mode-selector to its previous position. After the engine is warmed up, make the range selection again.

**CAUTION**

- Do not operate the drive mode-selector while the rear wheels of the vehicle are slipping on snow or ice.

**Drive mode indicator display and 2WD/4WD operation indicator display**

E00606001660

**6**

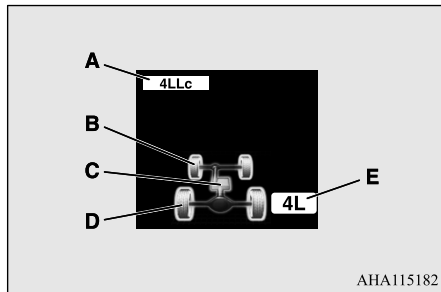

AHA115182

- A: Drive mode indicator display
- B: Front wheel indicator display
- C: Centre differential lock indicator display
- D: Rear wheel indicator display
- E: Low-range indicator display

When the ignition switch is the “ON” position or the operation mode is put in ON, drive mode indicator display (A) and 2WD/4WD operation indicator display (B, C, D, E) shows the shifting condition. The drive mode indicator display and 2WD/4WD operation indicator display comes on at each drive mode-selector position as follows:

**“2H” ↔ “4H”**

Drive mode-selector position	Indicator display
2H	
Drive mode switching in progress	
4H	

: Blink (Drive mode indicator display also blinks)

: Illuminate

: Remain off

**“4H” ↔ “4HLc”**

Drive mode-selector position	Indicator display
4H	
Drive mode switching in progress	
4HLc	

: Blink (Drive mode indicator display also blinks)

: Illuminate

: Remain off

“4HLc” ↔ “4LLc”

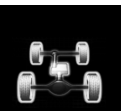
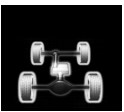
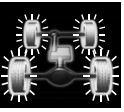
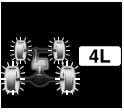
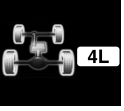
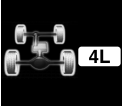
Drive mode-selector position	Indicator display	
4HLc		
Drive mode switching in progress	↓	↑
		
4LLc	↓	↑
		

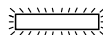
: Blink (Drive mode indicator display also blinks)

: Illuminate

: Remain off

 **NOTE**

- When the drive mode-selector is set between “2H”, “4H” and “4HLc”, the front wheel and/or centre differential lock displays blink while the selection is in process. Take the following precautions when the indicator display is blinking.
  - Keep the steering wheel in the straight ahead position while making range selections. If you attempt to drive forward with the steering wheel turned, gear rattling or shock may occur and cornering may not be smooth and the desired range may not actually be selected.
- When the drive mode-selector is set between “2H”, “4H” and “4HLc”, while the vehicle is stopped, the front wheel and/or centre differential lock displays blink while the selection is in process. Drive slowly and normally after confirming that the display is switched.
- If the front wheel and/or centre differential lock displays blinking after a “2H” ↔ “4H” ↔ “4HLc” selection has been made with the vehicle moving, hold the steering wheel in the straight ahead position and slowly depress the accelerator pedal several times.
- The front and the rear wheel displays will blink during shifting process from “4HLc” to “4LLc” or vice versa, as the transfer passes through the neutral position. Be sure to operate the drive mode-selector until the front and the rear wheel displays illuminate again.

 **NOTE**

- When parking, apply the parking brake before stopping the engine and make sure that the front and the rear wheel displays are not blinking during shifting process between “4HLc” ↔ “4LLc”. Otherwise, the vehicle could unexpectedly move even if the A/T is in the “P” (PARK) position.
- If, after a “4HLc” ↔ “4LLc” selection has been made, front and the rear wheel displays continue blinking and the desired range is not actually selected, return the drive mode-selector to its previous position. Place the steering wheel in the straight ahead position, drive the vehicle forward, and release the accelerator pedal. Next, hold down the clutch pedal (with M/T) or place the selector lever in the “N” (NEUTRAL) position (with A/T), depress and hold the brake pedal and make the range selection again.
- If the front and the rear wheel displays blink when you attempt to make a “4HLc” ↔ “4LLc” selection, a “4HLc” ↔ “4LLc” selection cannot be made. Stop the vehicle and release the accelerator pedal. Next, hold down the clutch pedal (with M/T) or place the selector lever in the “N” (NEUTRAL) position (with A/T), depress and hold the brake pedal and make the range selection again.

**6**

## Super Select 4WD II\*

6

### NOTE

- If the selector lever is shifted from the “N” (NEUTRAL) position to the other position or release the brake pedal during shifting process between “4HLc ↔ 4LLc”, the warning display will appear and the shifting process will be stopped (A/T).

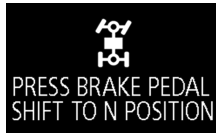

- If the clutch pedal is released during shifting process between “4HLc ↔ 4LLc”, the warning display will appear and the shifting process will be stopped (M/T).



- The active stability control function is suspended while “4LLc” is selected.  indicator lamp is illuminated while these functions are suspended. It does not indicate a problem. When “2H” or “4H” or “4HLc” is selected, this lamp goes out and function again. Refer to “ASTC indicator lamp or ASTC OFF indicator lamp” on page 6-74.

### CAUTION

- If the warning display is displayed on the information screen in the multi information display, a problem has occurred with the Super Select 4WD II and the safety device has activated. If this happens, please contact your nearest authorised MITSUBISHI MOTORS dealer for inspection as soon as possible.



## Off Road mode\*

E00642500109

The Off Road mode is the function that enhances driving smoothly on the off-road by selecting the most suitable engine, transmission, and brake control according to the road surface conditions when the drive mode position is in “4H” or “4L” (Easy Select 4WD), “4HLc” or “4LLc” (Super Select 4WD II). Also refer to “Easy Select 4WD” on page 6-35 or “Super Select 4WD II” on page 6-42.

### NOTE

- If the driver fails to select an appropriate mode in the Off Road mode, driving will be difficult.
- Depending on the mode selected, you may hear the operation noise or feel the vibration, or shock on the vehicle body.

6

## Control mode

E00642600096

It is possible to select the control mode from the followings according to the road surface conditions.

Control mode	functions	Drive mode-selector dial position	
		Easy Select 4WD	Super Select 4WD II
GRAVEL	Suitable to drive on unpaved road surfaces with gravel and soil.	4H or 4L	4HLc or 4LLc
MUD/SNOW	Suitable to drive on muddy areas or deep snows.	4H or 4L	4HLc or 4LLc
SAND	Suitable to drive on fine sand areas.	4H or 4L	4HLc or 4LLc
ROCK	Suitable to drive on the rough road surface such as rocky roads or with some wheels suspended in the air.	4L	4LLc

### NOTE

- When stuck, use the rear differential lock (if so equipped). (Refer to page 6-51)

### Off Road mode-selector operation

E00642700215

**6**

1. Bring the vehicle to a complete stop.
2. Set the drive mode-selector from “2H” to “4H” or “4L” (Easy Select 4WD), from “2H” or “4H” to “4HLc” or “4LLc” (Super Select 4WD II). At this time, the Off Road mode is switched to “GRAVEL” automatically.
3. The control mode is switched in the order of GRAVEL → MUD/SNOW → SAND → ROCK\* → GRAVEL by pressing the Off Road mode-selector.

\*: Only in 4L (Easy Select 4WD), 4LLc (Super Select 4WD II)

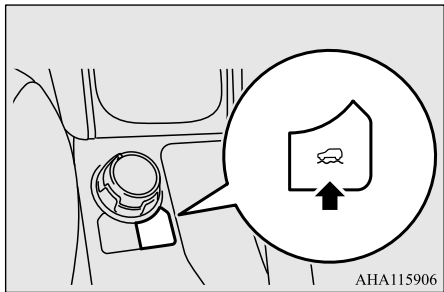

AHA115906

### NOTE

- When the rear differential lock switch is turned on while the Off Road mode is activated, the Off Road mode is returned to “GRAVEL” automatically if the rear differential lock switch is turned off.
- When changing the drive mode-selector to 4H (Easy Select 4WD), “4HLc” (Super Select 4WD II) while the Off Road mode is in “ROCK” mode, the Off Road mode is switched to “GRAVEL” automatically.
- When the Off Road mode-selector is held down while the Off Road mode is activated, the mode set to “GRAVEL”. After the mode is set, it cannot be changed even if the Off Road mode-selector is pressed. To change the control mode, restart the engine and press the Off Road mode-selector again.
- The Off Road mode is not activated when the drive mode is in “2H” (Easy Select 4WD), “2H” or “4H” (Super Select 4WD II). If the Off Road mode-selector is pressed when the drive mode-selector is set to “2H” (Easy Select 4WD), “2H” or “4H” (Super Select 4WD II), the warning display will appear and the operation will be cancelled.  
Example: When the drive mode-selector of Super Select 4WD II is in “2H” or “4H”.

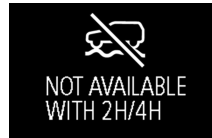

### Off Road mode indicator display

E00642800144

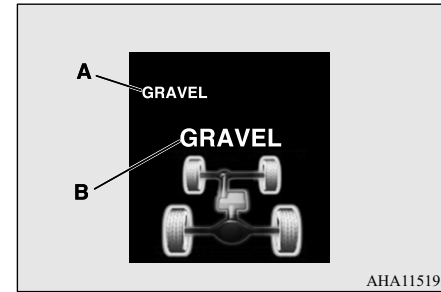

AHA115195

Example: When “GRAVEL” mode is selected The selected control mode is displayed on the Off Road mode indicator display (A). In addition, the selected mode is displayed as an interrupt display on the information screen of the multi information display (B) by switching the control mode. The control mode display on the information screen will return to the previous display after a few seconds.

### NOTE

- The Off Road mode will not operate even if pressing the Off Road mode-selector in the following conditions.
  - Brake System: brake temperature high

**NOTE**

- Rear Differential Lock (if so equipped): activating
- ASTC warning lamp: illuminating or blinking refer to “ASTC warning lamp/display” on page 6-75

**Rear differential lock\***

E00606201372

If one wheel starts to spin freely and the vehicle becomes stuck and cannot be freed even using 4-wheel drive, the rear differential lock switch (A) can be used to activate the rear differential lock for extra traction.

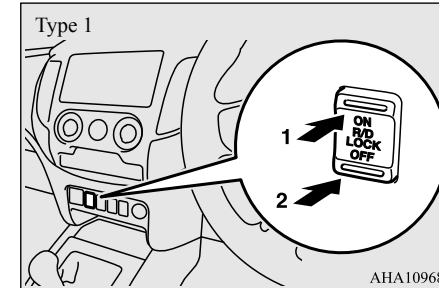
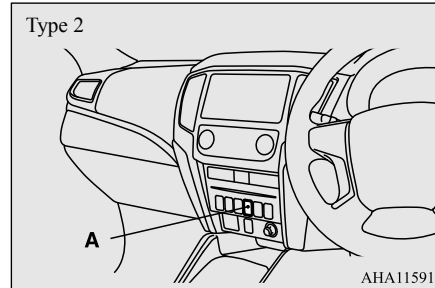
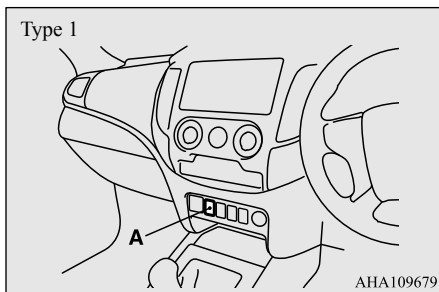

**6**

**Operating the rear differential lock**

1. Bring the vehicle to a complete stop.
2. Move the drive mode-selector to “4L” or “4H” position (Easy Select 4WD), “4LLc” or “4HLc” position (Super Select 4WD II).
3. To activate the rear differential lock, press the rear differential lock switch (1).
4. To deactivate the rear differential lock, press the rear differential lock switch (2).

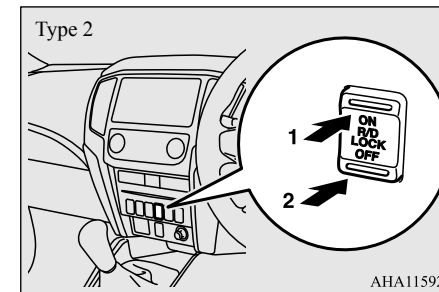

**CAUTION**

- Operate the rear differential switch after the wheels are stopped. Operating the switch with the wheels turning may cause the vehicle to dart in unexpected directions.



## Rear differential lock\*

6

### NOTE

- The rear differential lock does not operate when the drive mode-selector is in “2H” position (Easy Select 4WD), “2H” or “4H” position (Super Select 4WD II).
- When the rear differential is locked with the drive mode-selector in “4L” or “4H” position (Easy Select 4WD), “4LLc” or “4HLc” position (Super Select 4WD II) changing the drive mode-selector to “2H” position (Easy Select 4WD), “2H” or “4H” position (Super Select 4WD II) makes the rear differential unlock automatically.
- Vehicles equipped with the color liquid crystal display, if the rear differential lock switch is turned on during driving, the warning display will appear, the buzzer will sound and the rear differential lock will remain deactivated.



- Vehicles equipped with the mono-color liquid crystal display except for short wheel base vehicles, if the rear differential lock switch is turned on during driving, the buzzer will sound and the rear differential lock will remain deactivated.

### The rear differential lock indicator lamp/display

E00606301807

When the ignition switch is turned to the “ON” position or the operation mode is put in ON, the rear differential lock indicator lamp/display in the meter cluster illuminates for a few seconds then indicates the rear differential lock’s operating status (activated or deactivated).

[Vehicles equipped with the mono-color liquid crystal display]

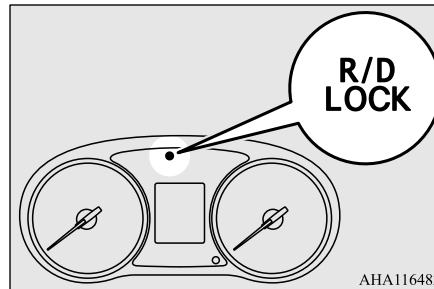

AHA116482

[Vehicles equipped with the color liquid crystal display]

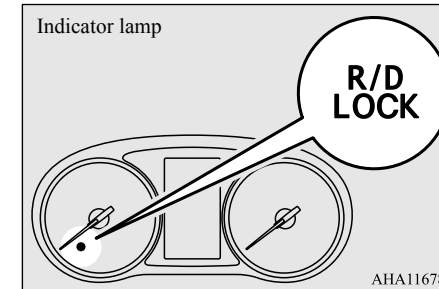

AHA116785

### Indicator display

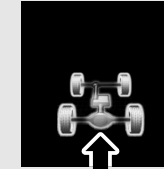





AHA116798

### NOTE





- The status of the rear differential lock (resulting from depression of the rear differential lock switch) is shown by blinking or steady illumination of the rear differential lock indicator lamp/display.

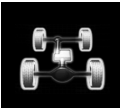

[Vehicles equipped with the mono-color liquid crystal display]

The operation state of rear differential lock	Rear differential lock indicator lamp
Rear differential lock deactivated	R/D LOCK ↑↓
Switching in progress	 ↑↓
Rear differential lock activated	R/D LOCK

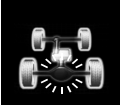
 : Blink  
 : Illuminate (steady)  
 : Remain off

[Vehicles equipped with the color liquid crystal display]

The operation state of rear differential lock	Rear differential lock indicator lamp/display	
	Indicator lamp	Indicator display
Rear differential lock deactivated	R/D LOCK ↑↓	 ↑↓
Switching in progress	 ↑↓	 ↑↓
Rear differential lock activated	R/D LOCK ↑↓	 ↑↓

 : Blink (Drive mode indicator display also blinks)  
 : Illuminate (steady)

 : Remain off

 **NOTE**

- The indicator lamp/display and drive mode indicator display (vehicles equipped with the color liquid crystal display) blink while the rear differential lock is being switched between its activated and deactivated conditions. When the switching operation is complete, the indicator lamp/display is either illuminated steadily or not illuminated.
- The ASTC and ABS functions are suspended while the rear differential lock is activated. ASTC indicator lamp, ASTC OFF indicator lamp and ABS warning lamp/display are illuminated while these functions are suspended. It does not indicate a problem. When the rear differential lock is disengaged, these lamps go out and function again. Refer to “ABS warning lamp/display” on page 6-70, “ASTC indicator lamp or ASTC OFF indicator lamp” on page 6-74.
- If the indicator lamp/display continues blinking after the switch has been pressed to deactivate the rear differential lock, hold the steering wheel in the straight ahead position then slowly depress and release the accelerator pedal several times.
- If the indicator lamp/display continues blinking after the switch has been pressed to activate the rear differential lock, bear in mind the following instructions:

## Rear differential lock\*

6

### NOTE

- If the vehicle speed is 12 km/h or higher, decelerate to a speed of 2.5 km/h or lower. The indicator lamp/display illuminates steadily and the rear differential lock will be activated.
- If the vehicle speed is 12 km/h or lower, turn the steering wheel from side to side until the indicator lamp/display illuminates steadily. If the vehicle is stuck in soft ground, make sure the area around the vehicle is clear then repeatedly attempt to drive forward and backward. The indicator lamp/display will illuminate steadily and the rear differential lock will be activated.

### CAUTION

- If a problem is detected in the rear differential lock system, a safety device will activate. The rear differential lock indicator lamp will blink rapidly (twice per second), warning display will appear, and the rear differential lock will deactivate. Park your vehicle in a safe place, turn off the engine for a few moments. Restart the engine. It is safe to continue driving if the lamps/display resume normal operation. If the rear differential lock indicator lamp blinks and warning display appears when the rear differential lock is reactivated, have the vehicle checked by an authorised MITSUBISHI MOTORS dealer as soon as possible.

Warning display (color liquid crystal display)

R/D  
LOCK!  
R/D LOCK  
SERVICE REQUIRED

### Examples of effective use of the rear differential lock

E00606401257

### CAUTION

- Use the rear differential lock only as an emergency measure when the vehicle is stuck and cannot be freed with the drive mode-selector in “4L” or “4H” position (Easy Select 4WD) or in “4LLc” or “4HLc” position (Super Select 4WD II). Deactivate the rear differential lock immediately after using it.

### When one of the wheels has fallen in a ditch

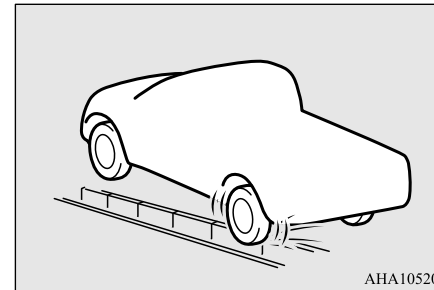

AHA105206

### When driving on rocky roads

When the vehicle is unable to move because one of the wheels is suspended in the air.

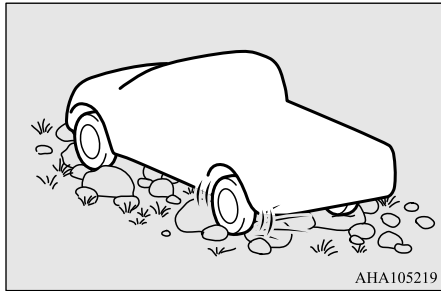

AHA105219

### When getting out of snow

When the vehicle is unable to get going because one of the wheels is on the snow and the other on a paved road.

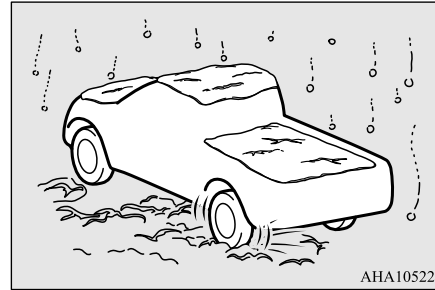

AHA105222

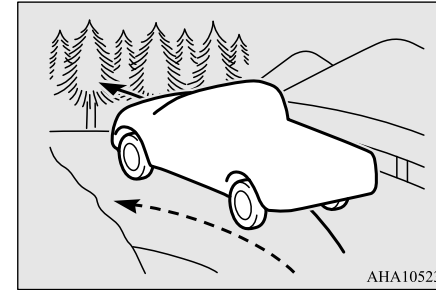

AHA105235

### Examples of incorrect use of the rear differential lock

E00606501229

#### ⚠ WARNING

- If the “4L” or “4H” position (Easy Select 4WD), the “4LLc” or “4HLC” position (Super Select 4WD II) is selected along with the rear differential lock, the following phenomena appear and it is very dangerous. Please be sure to release the rear differential lock on normal roads.
- If the rear differential lock is used by mistake when driving on a paved road: With the rear differential lock on, the power to drive the vehicle straight ahead becomes very strong, which may make it difficult to turn the steering wheel.

#### ⚠ WARNING

- If the rear differential lock is used by mistake when turning a curve or making a right or left turn at a crossing or the like: The vehicle is unable to make a turn and may go straight ahead.

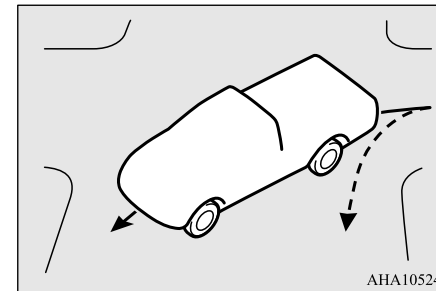

AHA105248

## 4-wheel drive operation\*

6

### **⚠ WARNING**

- If the rear differential lock is used by mistake except when making an emergency escape on snow or frozen road: It becomes difficult to make a steady turn.
- In the case where the condition of the road is different for the right tyre to drive from the left tyre (such as one tyre on a paved road and the other on ice), direction of the vehicle may change abruptly when engine braking or accelerating.  
Do not use the rear differential lock except when making an emergency escape on a snow or frozen road, but drive with 4WD.

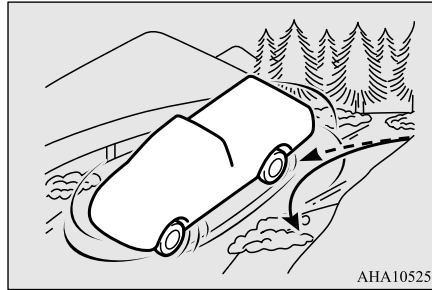

## 4-wheel drive operation\*

E00606602591

By selecting 4-wheel drive, both axles of the vehicle are rigidly connected with each other. This improves the traction characteristics. When turning sharp corners or moving forward and backward repeatedly, however, the drive line is stressed, which is felt as a braking effect. A 4-wheel drive vehicle can accelerate more quickly and smoothly.

However, note that the braking distance is not shorter than that of a rear-wheel drive vehicle.

When using 4-wheel drive on rough roads (snow, mud, sand, etc.), it is important to operate the vehicle correctly.

### **⚠ WARNING**

- Control the accelerator pedal, brake pedal, steering wheel, etc. according to the landform and nature of the soil. The driver should accurately grasp the surrounding circumstances and drive carefully according to the respective circumstances. Especially, the off-road may lead to loss of control and roll onto vehicle's side or roof, which may cause an accident resulting in serious personal injury or death in the worst case.

**NOTE**

- The driving posture should be more upright and closer to the wheel than usual; adjust the seat to a good position for easy steering and pedal operation. Be sure to wear the seat belt.
- After driving on rough roads, check each part of the vehicle and wash it thoroughly with water. Refer to the “Vehicle care” section and “Inspection and maintenance following rough road operation” on page 6-62.

Even a vehicle without the equipment for Off Road mode and rear differential lock (if so equipped) run each road condition. The vehicle with each equipment set the recommended mode of the list shown below in each road condition, it may help you drive smoothly.

Driving mode	Road conditions					
	Dry paved road and highway	Packed snow road	Gravel road	Deep snow or muddy road	Sandy road	Rocky road
Easy Select 4WD (→ P.6-35)	2H	4H	4H or 4L	4H or 4L	4H or 4L	4H or 4L
Super Select 4WD II (→ P.6-42)	2H or 4H	4H	4HLc or 4LLc	4HLc or 4LLc	4HLc or 4LLc	4HLc or 4LLc
Off Road mode-selector (→ P.6-50)	–	–	GRAVEL	MUD/SNOW	SAND	ROCK
Rear differential lock (→ P.6-51)	–	–	–	Active*	Active*	Active*

**6**

\*:The Off Road mode and the rear differential lock cannot be used at the same time. When the rear differential lock is set to ON, the Off Road mode turns off. In addition, when the rear differential lock is ON, the Off Road mode will be deactivated even if the Off Road mode-selector is operated.

**CAUTION**

- When driving on the off-road, confirm the conditions of the road surface and the landscape, and drive after confirming that the components of the suspension and the bottom of the front and rear bumper do not contact with the road surface. (Refer to “Vehicle dimensions” on page 11-3.)

## 4-wheel drive operation\*

### Driving on dry paved road and highway

E0064640050

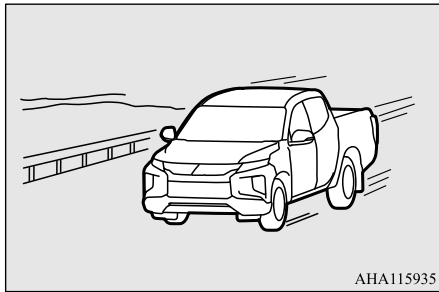

AHA115935

Set the drive mode-selector to “2H” position (Easy Select 4WD), “2H” or “4H” position (Super Select 4WD II) to drive on the dry paved road. Especially on dry highway, never select “4H” or “4L” position (Easy Select 4WD), “4HLc” or “4LLc” position (Super Select 4WD II).

### CAUTION

- Selecting “4H” or “4L” position (Easy Select 4WD), “4HLc” or “4LLc” position (Super Select 4WD II) to drive on dry paved road will increase the fuel consumption with possible noise generation and early tyre wear. It may also increase the differential oil temperature, resulting in possible damage to the driving system. Further, the drive train will be subjected to excessive loading, possibly leading to oil leakage, component seizure, or other serious faults.

### Driving on packed snow roads

E0064650051

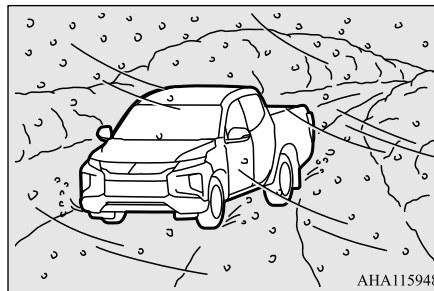

AHA115948

Set the drive mode-selector to “4H” position, in accordance with the road conditions, and then gradually depress the accelerator pedal for a smooth start.

### NOTE

- The use of snow tyres and/or tyre chains is recommended.
- Maintain a safe distance between vehicles, avoid sudden braking, and use engine braking (downshifting).

### CAUTION

- Avoid sudden braking, sudden acceleration, and sharp turning; such operations could cause skidding and spinouts.

### Driving on unpaved roads

E0064660052

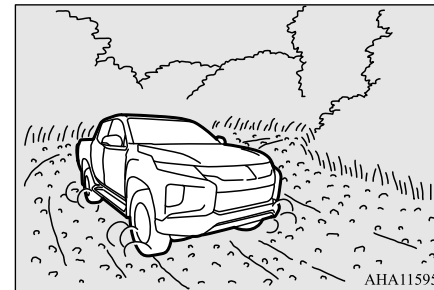

AHA115951

Check the road surface conditions and set the drive mode-selector to “4H” or “4L” position (Easy Select 4WD), “4HLc” or “4LLc” position (Super Select 4WD II). Setting the Off

Road mode-selector (if so equipped) to “GRAVEL” may help you drive smoothly.

### Driving on deep snow or muddy roads

E00647300203

Set the drive mode-selector to “4H” or “4L” position (Easy Select 4WD), “4HLc” or “4LLc” position (Super Select 4WD II) and then gradually depress the accelerator pedal for a smooth start. Keep the pressure on the accelerator pedal as constant as possible, and drive at low speed.

Set the Off Road mode-selector (if so equipped) to “MUD/SNOW”, or set the rear differential lock (if so equipped) to ON if the vehicle is likely to get stuck. This may help you drive smoothly.

### WARNING

- When attempting to rock your vehicle out of a stuck position, be sure that the area around the vehicle is clear of people and physical objects. The rocking motion may cause the vehicle to suddenly launch forward or backward, causing injury or damage to nearby people or objects.

### CAUTION

- If any of following conditions occur while the vehicle is being driven, immediately park your vehicle in a safe place and follow these procedures:
  - The bar graph of engine coolant temperature display approaches the overheating zone. Refer to “Engine overheating” on page 8-4.
  - A/T fluid temperature warning display comes on. Refer to “When a malfunction occurs in the A/T” on page 6-33.

### NOTE

- Avoid sudden braking, acceleration, and turning; such operations could result in the vehicle becoming stuck.
- If the vehicle becomes stuck in deep snow or muddy roads, it can often be moved a rocking motion. Move the selector lever rhythmically between the “D” (DRIVE) and “R” (REVERSE) position (with M/T, between 1st and Reverse), while applying slight pressure to the accelerator pedal.
- It is recommended to start the vehicle with parking brake partially, but not completely, applied by slightly pulling the parking brake lever. After the vehicle has become free, do not forget to release the parking brake.

### NOTE

- If it is necessary to drive in extremely muddy conditions, the use of tyre chains is recommended. Because the extent of muddy conditions is difficult to judge and the vehicle could become bogged down very deeply, operation should be at a low speed. If possible, get out of the vehicle and check the conditions ahead before proceeding.
- Driving over roads in coastal areas or roads on which anti-skid preparations have been spread can cause rust on the vehicle; wash the vehicle thoroughly as soon as possible after such use.

6

### Driving on sandy roads

E00646700079

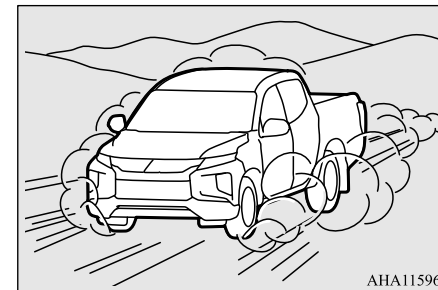

AHA115964

Check the sandy road condition and set the drive mode-selector to “4H” or “4L” position (Easy Select 4WD), “4HLc” or “4LLc” position (Super Select 4WD II). Gradually



## 4-wheel drive operation\*

depress the accelerator pedal to start the vehicle and drive at a possible constant low speed. Either set the Off Road mode-selector (if so equipped) to “SAND”, or set the rear differential lock (if so equipped) to ON if the vehicle is likely to get stuck. This may help you drive smoothly.

6

### **CAUTION**

- Do not force the vehicle or drive recklessly on sandy surfaces. In comparison with normal road surfaces, the engine and other drive-system components are put under excessive strain when driving on such a surface, and this could lead to accidents.

### **Driving on rocky road**

E0064680070

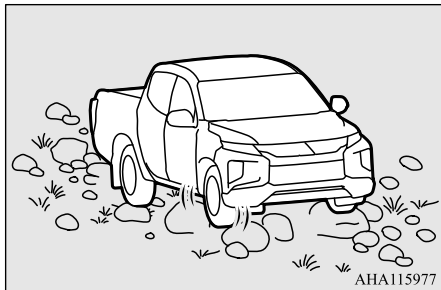

AHA115977

Set the drive mode-selector to “4H” or “4L” position (Easy Select 4WD), “4HLc” or

“4LLc” position (Super Select 4WD II) and drive at a low speed. Depending on the road condition, either set the Off Road mode-selector (if so equipped) to “ROCK”, or set the rear differential lock (if so equipped) to ON if the vehicle is likely to get stuck. This may help you drive smoothly.

### **CAUTION**

- Avoid driving alone on rocky roads. When driving on rocky roads, follow an experienced driver’s instruction for safe driving.

### **NOTE**

- Drive on a road surface where the tyre treads contact with rocks as far as possible.

### **Descending steep grades**

E0064690097

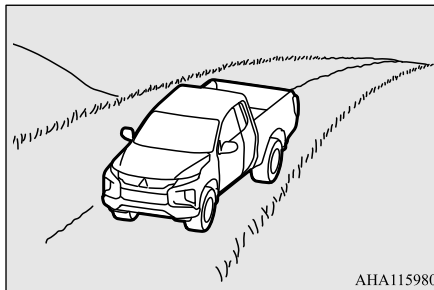

AHA115980

Set the drive mode-selector to “4H” or “4L” position (Easy Select 4WD), “4HLc” or “4LLc” position (Super Select 4WD II), use the engine brake (downshifting) and descend slowly.

If the vehicle cannot descend slowly even using the engine brake. The Hill Descent Control (if so equipped) may help drive smoothly.

For details, refer to “Hill Descent Control (HDC)” on page 6-66.

### **WARNING**

- Avoid snaking down a sharp grade. Descend the grade as straight as possible.

### **NOTE**

- When descending a sharp grade, if the brakes are applied suddenly because of an obstacle encountered, control of the vehicle could be lost. Before descending the slope, walk down it and confirm the path.
- Before descending a grade, it is necessary to choose the appropriate gear. Avoid changing gears while descending the grade.

**NOTE**

● MITSUBISHI MOTORS is not responsible to the operator for any damage or injury caused or liability incurred by the improper and negligent operation of a vehicle. All techniques of vehicle operation described herein depend on the skill and experience of the operator and other participating parties and any deviation from the recommended operation instructions above is at their own risk.

**Climbing steep grades**

E0064700082

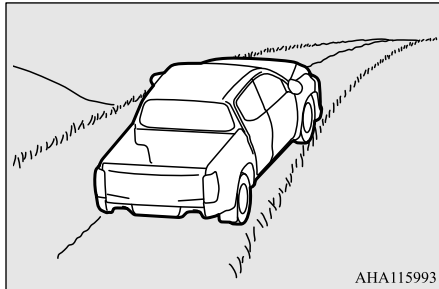

AHA115993

Set the drive mode-selector to “4L” position (Easy Select 4WD), “4LLc” position (Super Select 4WD II) to maximize the engine torque.

**WARNING**

- Go straight up. Do not try to traverse across a steep slope.
- If you begin to lose traction, ease off the accelerator pedal and gently turn the steering wheel alternatively left and right to regain adequate traction again.

**NOTE**

- Choose as smooth a slope as possible with few stones or other obstacles.
- Before attempting to drive up the slope, walk up it to confirm that the vehicle can handle the grade.

**Turning sharp corners**

E00647100054

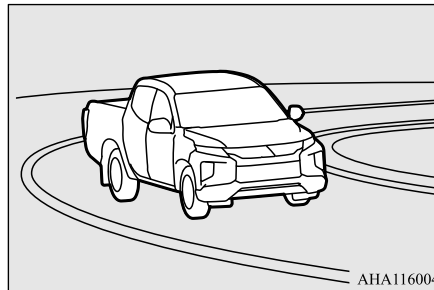

AHA116004

When turning a sharp corner in “4H” or “4L” position (Easy Select 4WD), “4HLc” or

“4LLc” position (Super Select 4WD II) at low speed, a slight difference in steering may be experienced similar to as if the brakes were applied. This is called tight corner braking and results from each of the 4 tyres being at a different distance from the corner. The phenomenon is peculiar to 4-wheel drive vehicles. If this occurs, either straighten the steering wheel, or change to “2H” position (Easy Select 4WD), “2H” or “4H” position (Super Select 4WD II).

**Crossing a stream**

E00647200068

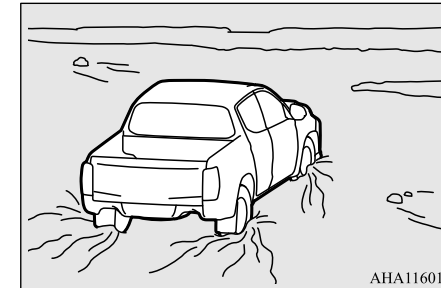

AHA116017

4-wheel drive vehicles are not necessarily waterproof. If the electrical circuits become wet, further operation of the vehicle will be impossible; therefore, avoid crossing streams unless absolutely necessary. If crossing a stream is unavoidable, use the following procedure:

## Inspection and maintenance following rough road operation

1. Check depths of a stream and geographical features before attempting to cross a stream and ford the stream where the water is as shallow as practicable.
2. Set the drive mode-selector to “4L” position (Easy Select 4WD), “4LLc” position (Super Select 4WD II).
3. Drive slowly at a speed of approximately 5 km/h to avoid splashing too much water.

6

### CAUTION

- Never cross a stream where the water is deep.  
Do not change gears while crossing the stream.  
Frequent crossing of streams can adversely affect the life span of the vehicle; consult an authorised MITSUBISHI MOTORS dealer and take the necessary measures to prepare, inspect, and repair the vehicle.
- After crossing a stream, apply the brakes to be sure they are functioning properly. If the brakes are wet and not functioning properly, dry them out by driving slowly while lightly depressing the brake pedal.

### Inspection and maintenance following rough road operation

E00606701540

After operating the vehicle in rough road conditions, be sure to perform the following inspection and maintenance procedures:

- Check that the vehicle has not been damaged by rocks, gravel, etc.
- Carefully wash the vehicle with water.  
Drive the vehicle slowly while lightly depressing the brake pedal in order to dry out the brakes. If the brakes still do not function properly, contact an authorised MITSUBISHI MOTORS dealer as soon as possible to have the brakes checked.
- Remove the insects, dried grass, etc. clogging the radiator core and A/T oil cooler.
- After crossing a stream, be sure to have the following items inspected at an authorised MITSUBISHI MOTORS dealer and take the necessary measures.
  - Check the brake system and, if necessary, have it serviced.
  - Check the engine, transmission, transfer, and differential oil or grease level and turbidity. If the oil or grease is milky, it indicates water contamination. Replace it with new oil or grease.
- Grease the propeller shaft.

- Check the inside of the vehicle. If ingress of water is found, dry the carpet etc.
- Inspect the headlamps. If the headlamp bulb is flooded with water, have the headlamp drained off.

### Cautions on handling of 4-wheel drive vehicles\*

E00606802261

### Tyres and wheels

Since the driving torque can be applied to the 4 wheels, the performance of the vehicle when operating in 4-wheel drive is greatly affected by the condition of the tyres.

Pay close attention to the tyres.

- Install specified tyres on all wheels. Refer to “Tyres and wheels” on page 11-13.
- Be sure to the appropriate tyre inflation pressure according to no cargo or cargo. Refer to “Tyre inflation pressures” on page 10-12.
- Be sure to fit all 4 tyres and wheels of the same size and type.  
When replacement of any of the tyres or wheels is necessary, replace all of them.

## Cautions on handling of 4-wheel drive vehicles\*

- All tyres should be rotated whenever the wear difference between the front and rear tyres is recognizable.

Good vehicle performance cannot be expected if there is a difference in wear between tyres. Refer to “Tyre rotation” on page 10-13.

- Check the tyre inflation pressure regularly.

### CAUTION

- Always use tyres of the same size, same type, and same brand which have no wear differences. Using the tyres which differ in size, type, brands or the degree of wear or the inappropriate tyre inflation pressure, will increase the differential oil temperature and may be impossible to shift the transfer, resulting in possible damage to the driving system. Further, the drive train will be subjected to excessive loading, possibly leading to oil leakage, component seizure, or other serious faults.

## Towing

If towing is necessary, we recommend you to have it done by your MITSUBISHI MOTORS dealer or a commercial tow truck service.

In the following cases, transport the vehicle using a tow truck.

- The engine runs but the vehicle does not move or abnormal noise is produced.
- Inspection of the vehicle’s underside reveals that oil or some other fluid is leaking.

Only when you cannot receive a towing service from a MITSUBISHI MOTORS dealer or commercial tow truck service, tow your vehicle carefully in accordance with the instructions given in “Towing” on page 8-19.

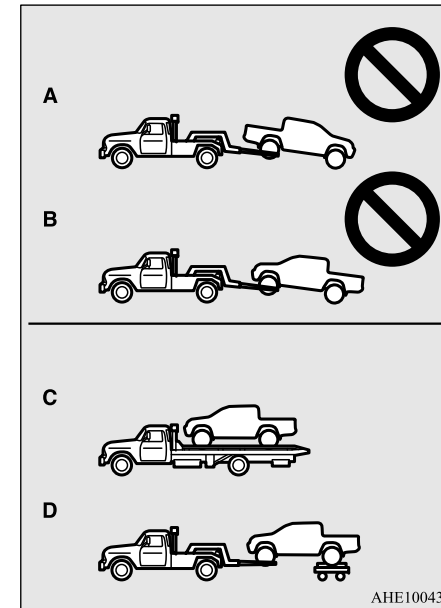

### CAUTION

- Transport the vehicle with the driving wheels on a carriage (Type C or D) as illustrated. Never try to tow with the front or rear wheels on the ground (Type A or B) as illustrated. This could result in damage to the drivetrain, or unstable towing.

## Limited-slip differential\*

### Jacking up a 4-wheel drive vehicles

#### WARNING

- Do not crank the engine while jacking up the vehicle.  
The tyre on the ground may turn and the vehicle may roll off the jack.

6

### Limited-slip differential\*

E00606900037

A limited-slip differential is applied for the rear wheel differential only. The features of this limited-slip differential are described below:

Just as with a conventional differential, the wheel on one side is allowed to turn at a different speed from the wheel on the other side when the vehicle is cornering. The difference between the limited-slip differential and a conventional differential is that if the wheel on one side of the vehicle loses traction, a greater amount of torque is applied to the wheel on the other side to improve traction.

#### NOTE

- Even if there is a difference in the amount of traction the wheels can get, if both of them are spinning, the limited-slip differential will not be effective.

#### CAUTION

- Never start the engine while one of the rear wheels is jacked up and the other in contact with the ground; doing so may cause the vehicle to jump forward.
- When attempting to extract the vehicle from snow, mud, etc., and the engine is run continuously at high speed, the limited-slip differential will be adversely affected.

### Braking

E00607003384

All the parts of the brake system are critical to safety. Have the vehicle serviced by an authorised MITSUBISHI MOTORS dealer at regular intervals according to the service booklet.

#### CAUTION

- Avoid driving habits that cause heavy braking and never “ride” the brakes by resting your foot on the brake pedal while driving. It causes brake overheating and fade.

### Brake system

The service brake is divided into two brake circuits. And your vehicle is equipped with power brakes. If one brake circuit fails, the other is available to stop the vehicle. If your vehicle should lose the power assist for some reason, the brakes will still work. In these situations, even if the brake pedal moves down to the very end of its possible stroke or resists being depressed, keep depressing the brake pedal down harder and further than usual; stop driving as soon as possible and have the brake system repaired.

#### WARNING

- Do not turn off the engine while your vehicle is in motion.  
If you turn off the engine while driving, the power assistance for the braking system will stop working and your brakes will not work effectively.
- If the power assist is lost or if either brake hydraulic system stops working properly, take your vehicle to an authorised MITSUBISHI MOTORS dealer immediately.

## Warning lamp/display

The brake warning lamp illuminates to indicate a fault in the braking system. Refer to “Brake warning lamp” on page 5-50.

## When brakes are wet

Check the brake system while driving at a low speed immediately after starting, especially when the brakes are wet, to confirm they work normally.

A film of water can be formed on the brake discs or brake drums and prevent normal braking after driving in heavy rain or through large puddles, or after the vehicle is washed. If this occurs, dry the brakes out by driving slowly while lightly depressing the brake pedal.

## When driving downhill

It is important to take advantage of the engine braking by shifting to a lower shift position while driving on steep downhill roads in order to prevent the brakes from overheating.

### WARNING

- Do not leave any objects near the brake pedal or let a floor mat slide under it; doing so could prevent the full pedal stroke that would be necessary in an emergency. Make sure that the pedal can be operated freely at all times. Make sure the floor mat is securely held in place.

## Brake pads

- Avoid hard braking situations. New brakes need to be broken-in by moderate use for the first 200 km.
- The disc brakes are provided with a warning device which emits a shrieking metallic sound while braking if the brake pads have reached their wear limit. If you hear this sound, have the brake pads replaced by your MITSUBISHI MOTORS dealer.

### WARNING

- Driving with worn brake pads will make it harder to stop, and can cause an accident.

## Hill start assist\*

E00628000214

The hill start assist makes it easy to start off on a steep uphill slope by preventing the

vehicle from moving backwards. It keeps the braking force for about 2 seconds when you move your foot from the brake pedal to the accelerator pedal.

### CAUTION

- Do not overly rely on the hill start assist to prevent backwards movement of the vehicle. Under certain circumstances, even when hill start assist is activated, the vehicle may move backwards if the brake pedal is not sufficiently depressed, if the vehicle is heavily loaded, or if the road is very steep or slippery.
- The hill start assist is not designed to keep the vehicle stopped in place on uphill slopes for more than 2 seconds.
- When facing uphill, do not rely on using the hill start assist to maintain a stopped position as an alternative to depressing the brake pedal. Doing so could cause an accident.
- Do not turn the ignition switch to the “LOCK” or “ACC” position or the operation mode in ACC or OFF while the hill start assist is operating. The hill start assist could stop operating, which could result in an accident.

## Hill Descent Control (HDC)\*

### To operate

E00628101371

1. Stop the vehicle completely using the brake pedal.
2. On vehicles equipped with M/T, place the gearshift lever into the 1st position.  
On vehicles equipped with A/T, place the selector lever into the “D” position.

6

### NOTE

- When reversing on an uphill slope, place the selector lever or gearshift lever into the “R” position.

3. Release the brake pedal and the hill start assist will maintain the braking force applied while stopping for approximately 2 seconds.
4. Depress the accelerator pedal and the hill start assist gradually will decrease the braking force as the vehicle starts moving.

### NOTE

- The hill start assist is activated when all of the following conditions are met.
  - The engine is running.  
(The hill start assist will not be activated while the engine is starting or immediately after the engine is started.)

### NOTE

- On vehicles equipped with M/T, the gearshift lever is in the following position.  
[When starting an uphill slope forwards.]  
The gearshift lever is in any position other than “R”.  
(The hill start assist will operate, even if the gearshift lever is in the “N” position.)  
[When starting an uphill slope backwards.]  
The gearshift lever is in the “R” position.  
(The hill start assist will not operate when the gearshift lever is in the “N” position.)
- On vehicles equipped with A/T, the selector lever is in any position other than “P” or “N”.
- The vehicle is completely stationary, with the brake pedal depressed.
- The parking brake is released.
- The hill start assist will not operate if the accelerator pedal is depressed before the brake pedal is released.
- The hill start assist also operates when reversing on an uphill slope.
- When the hill start assist is activated, you may feel the operating sound.  
This is a normal result of the hill start assist operation, and does not indicate a problem.

### Warning lamp/display

E00628201792

If an abnormal condition occurs in the system, the warning lamp/display will turn on.

### Warning lamp



### Warning display

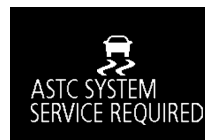

### CAUTION

- If the warning is turn on, the hill start assist will not operate. Start off carefully.
- Park your vehicle in a safe place and stop the engine.  
Restart the engine and check whether the warning indicator went out, in which case the hill start assist is again working normally. If the warning remains displayed or reappear frequently, it is not necessary to stop the vehicle immediately, but the vehicle should be inspected by an authorised MITSUBISHI MOTORS dealer.

### Hill Descent Control (HDC)\*

E00642900129

The Hill Descent Control is the system that assists the steady driving with the constant speed when descending sharp grades where it

is impossible to decelerate the vehicle sufficiently by the engine brake only or rough roads.

### **⚠ WARNING**

- **The driver has the responsibility to drive safely. Make sure to drive safely according to road conditions without relying too much on the Hill Descent Control.**
- **When driving slippery roads such as muddy, icy or unpaved roads, the vehicle will not allow you to stay at a certain low speed, which may lead to a serious accident.**
- **On vehicles with M/T, set the drive mode-selector to “4L” position (Easy Select 4WD) or “4LLc” position (Super Select 4WD II). If using the Hill Descent Control while driving except in “4LLc” position (Super Select 4WD II) or “4L” position (Easy Select 4WD), the engine may stall. As a result, it could lose the brake effectiveness or lock the tyres, which may lead to a serious accident.**

### **⚠ CAUTION**

- When there is a malfunction in the Hill Descent Control system, ASTC warning lamp come on. When ASTC warning lamp come on, have the vehicle inspected at an authorised MITSUBISHI MOTORS dealer. (Refer to “ASTC warning lamp/display” on page 6-75.)  
When the warning lamp comes on, the warning display may also appear.

### **To operate**

E00643000114

1. Bring the vehicle to a complete stop.
2. On vehicles with M/T, place the gearshift lever into the 1st position or the “R” (Reverse) position.  
On vehicles with A/T, place the selector lever into the “D” (DRIVE) position or the “R” (REVERSE) position.
3. Press the Hill Descent Control switch.

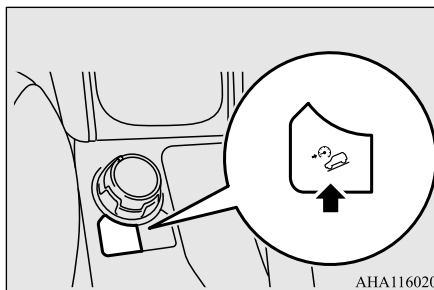

### **Hill Descent Control (HDC)\***

4. Make sure that Hill Descent Control indicator lamp comes on.

When the Hill Descent Control indicator lamp comes on, the Hill Descent Control set to ON (stand by).

Indicator lamp



### **📖 NOTE**

- The indicator lamp should illuminate when the operation mode is put in ON and should go off after a few seconds.
- If pressing the Hill Descent Control continuously after setting the Hill Descent Control to ON (stand by), the Hill Descent Control will return to OFF as a protection function is operated. After returning to OFF, the Hill Descent Control will not be switched to ON (Stand by) even if the Hill Descent Control switch is pressed. To set the Hill Descent Control to ON, restart the engine and press the Hill Descent Control switch again.
- It is impossible to set the Hill Descent Control to ON (stand by) in the following conditions.
  - Vehicle speed: More than approximately 20 km/h
  - Rear differential lock (if so equipped) : activating



## Brake assist system\*

### NOTE

- Brake system: brake temperature high
- ASTC warning lamp: illuminating or blinking  
Refer to “ASTC warning lamp/display” on page 6-75

In the following cases, the Hill Descent Control brake control operates.

**6**

- Vehicle speed: 20 km/h or less
- The accelerator pedal or the brake pedal is not operated.

When the control operates, the Hill Descent Control indicator lamp blinks, and the brake lamps and the high mounted stop lamp are illuminated. It is possible to change the controlled vehicle speed by operating the accelerator pedal or the brake pedal.

When you lift your foot off the pedal, the Hill Descent Control performs brake control so as to keep the vehicle speed at that time.

### NOTE

- The Hill Descent Control will not operate even if the Hill Descent Control is in ON (stand by), and the control will temporarily stop during the activation of it in the following conditions.
- Vehicle speed: More than approximately 20 km/h

### NOTE

- On vehicles with M/T, the gearshift lever is placed in the forward gear except the 1st position.
- When the Hill Descent Control is activated, you may feel the vehicle body, the steering wheel and the brake pedal vibrate and hear the operation noise. You may also feel the depressed brake pedal is solid or loose. This does not indicate a malfunction and the Hill Descent Control is operating normally.
- The Hill Descent Control indicator lamp blinks on a flat road, but this does not indicate a malfunction.

### To deactivate

E00643200086

1. Press the Hill Descent Control switch.  
The Hill Descent Control will be gradually released.
2. Make sure that the Hill Descent Control indicator lamp is off.

### NOTE

- The Hill Descent Control turns off automatically and the Hill Descent Control indicator lamp in the meter goes off without pressing the Hill Descent Control switch in the following conditions.
- Vehicle speed: More than approximately 80 km/h

### NOTE

- Rear differential lock (if so equipped): activating
- ASTC warning lamp: ON
- Brake system: brake temperature high

## Brake assist system\*

E00627001735

The brake assist system is a device assisting drivers who cannot depress the brake pedal firmly such as in emergency stop situations and provides greater braking force.

If the brake pedal is depressed suddenly, the brakes will be applied with more force than usual.

### CAUTION

- The brake assist system is not a device designed to exercise braking force greater than its capacity. Make sure to always keep a sufficient distance between your vehicle and a vehicle in front of you without relying too much on the brake assist system.

**NOTE**

- Once the brake assist system is operational, it maintains great braking force even if the brake pedal is lightly released. To stop its operation, completely remove your foot from the brake pedal.
- When the brake assist system is in use while driving, you may feel the brake pedal attempt to resist, the pedal moves in small motions in conjunction with the operation noise, or the vehicle body and the steering wheel vibrate. This occurs when the brake assist system is operating normally and does not indicate faulty operation. Continue to depress the brake pedal.
- When the active stability & traction control (ASTC) indicator lamp is illuminated, the brake assist system may not function.

**Emergency stop signal system\***

E00626001305

This is a device that reduces the possibility of rear end collisions by the rapid and automatic blinking of the hazard warning lamps to alert vehicles approaching from behind during sudden braking. When the emergency stop signal system operates, the hazard warning indicator lamp in the instrument cluster blinks rapidly at the same time.

**CAUTION**

- If the ABS warning or ASTC warning is displayed, the emergency stop signal system may not operate. Refer to “ABS warning lamp/display” on page 6-70. Refer to “ASTC warning lamp/display” on page 6-74.

**NOTE**

- [Activating condition for the emergency stop signal system]  
It activates when all of the following conditions are met.
  - The vehicle speed is approximately 55 km/h or higher.
  - The brake pedal has been depressed, and the system judges that it was sudden braking from the vehicle deceleration and the operating condition of the anti-lock brake system (ABS).
- [Deactivating condition for the emergency stop signal system]  
It deactivates when one of the following conditions is met.
  - The brake pedal is released.
  - The hazard warning flasher switch is pressed.
  - The system judges that it was not sudden braking from the vehicle deceleration and the operating condition of the anti-lock brake system (ABS).

**Anti-lock brake system (ABS)**

E00607102838

The anti-lock brake system (ABS) helps prevent the wheels from locking up when braking. This helps maintain vehicle drivability and steering wheel handling.

**Driving hints****6**

- Always keep a safe distance from the vehicle in front of you. Even if your vehicle is equipped with the ABS, leave a greater braking distance when:
  - Driving on gravel or snow-covered roads.
  - Driving with tyre chains installed.
  - Driving on roads where the road surface is pitted or has other differences in surface height.
  - Driving on uneven road surfaces.
- Operation of ABS is not restricted situations where brakes are applied suddenly. This system may also prevent the wheels from locking when you drive over manholes, steel roadwork plates, road markings, or any uneven road surface.

## Anti-lock brake system (ABS)

6

- When the ABS is in use, you may feel the brake pedal pulsation and the vibrations of the vehicle body and steering wheel. It may also feel as if the pedal resists being pressed.  
**In this situation, simply hold the brake pedal down firmly. Do not pump the brake, which will result in reduced braking performance.**
- An operation noise is emitted from the engine compartment or feel a shock from the brake pedal when start driving immediately after starting the engine. These are normal sound or operation that the ABS makes when performing a self-check. It does not indicate a malfunction.
- The ABS can be used after the vehicle has reached a speed over approximately 10 km/h. It stops working when the vehicle slows below 7 km/h.

### CAUTION

- The ABS cannot prevent accidents. It is your responsibility to take safety precautions and to drive carefully.
- To prevent failure of the ABS, be sure all 4 wheels and tyres are the same size and the same type.
- Do not install any aftermarket limited slip differential (LSD) on your vehicle. The ABS may stop functioning properly.

### ABS warning lamp/display

E00607202712

Warning lamp



Warning display



If there is a malfunction in the system, the ABS warning lamp will come on and the warning display will appear on the information screen in the multi information display. Under normal conditions, the ABS warning lamp comes on when the ignition switch is turned to the “ON” position or the operation mode is put in ON and goes off a few seconds later.

### CAUTION

- Any of the following warning lamp/display behaviour that the ABS is not functioning and only the standard brake system is working. (The standard brake system is functioning normally.) If this happens, please contact your nearest authorised MITSUBISHI MOTORS dealer for inspection.

### CAUTION

- When the ignition switch is turned to the “ON” position or the operation mode is put in ON, the warning lamp does not come on or it remains on and does not go off
- The warning lamp comes on while driving
- The warning display appears while driving

### NOTE

- On vehicles with the rear differential lock and the active stability & traction control (ASTC), the ASTC and ABS functions are suspended while the rear differential lock is activated. ASTC indicator lamp, ASTC OFF indicator lamp and ABS warning lamp are illuminated while these functions are suspended. It does not indicate a problem. When the rear differential lock is disengaged, these lamps go out and function again. Refer to “ASTC indicator lamp or ASTC OFF indicator lamp” on page 6-74.

## Anti-lock brake system (ABS)

### If the warning lamp/display illuminate while driving

#### ■ If only the ABS warning lamp illuminates

Avoid hard braking and high-speed driving. Stop the vehicle in a safe place.

Restart the engine and check to see whether the lamp goes out after a few minutes driving; if it then remains off during driving, there is no problem.

However, if the warning lamp/display do not disappear, or if they come on again when the vehicle is driven, have the vehicle checked by an authorised MITSUBISHI MOTORS dealer as soon as possible.

#### ■ If the ABS warning lamp/display and brake warning lamp/display illuminate at the same time

The ABS and brake force distribution function may not work, so hard braking could make the vehicle unstable.

Avoid hard braking and high-speed driving. Stop the vehicle in a safe place and contact an authorised MITSUBISHI MOTORS dealer.

Warning lamp

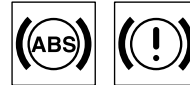

Warning display



#### NOTE

- The ABS warning lamp and brake warning lamp illuminate at the same time and the warning displays appear alternately on the information screen in the multi-information display.

### After driving on icy roads

E00618801229

After driving on snow or icy roads, remove any snow and ice which may have been left around the wheels. On vehicles that have an ABS, be careful not to damage the wheel

speed sensors (A) or the cables located at each wheel.

#### 2WD

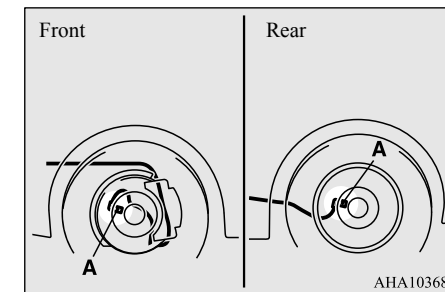

6

#### 2WD Hi-Rider, 4WD

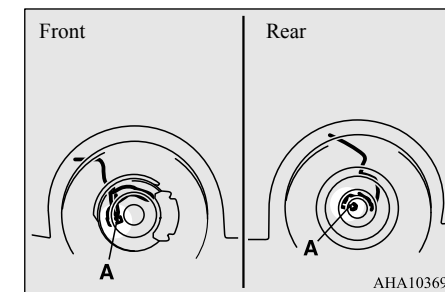

## Power steering system

E00607401472

The power steering system operates while the engine is running. It helps reduce the effort needed to turn the steering wheel.

The power steering system has mechanical steering capability in case the power assist is lost. If the power assist is lost for some reason, you will still be able to steer your vehicle, but you will notice it takes much more effort to steer. If this happens, have your vehicle inspected at an authorised MITSUBISHI MOTORS dealer.

6

### WARNING

- Do not stop the engine while the vehicle is moving. Stopping the engine would make the steering wheel extremely hard to turn, possibly resulting in an accident.

### CAUTION

- Do not leave the steering wheel turned all the way in one direction. This can cause damage to the power steering system.

## Active Stability & Traction Control (ASTC)\*

E00616701947

The active stability & traction control (ASTC) takes overall control of the anti-lock brake system, active stability control function and active traction control function to help maintain the vehicle's control and traction. Please read this section in conjunction with the page on the anti-lock brake system, active stability control function and active traction control function.

Anti-lock brake system (ABS) → P.6-69  
Active Stability Control function → P.6-73  
Active Traction Control function → P.6-74

### CAUTION

- Do not over-rely on the ASTC. Even the ASTC cannot prevent the natural laws of physics from acting on the vehicle. This system, like any other system, has limits and cannot help you to maintain traction and control of the vehicle in all circumstances. Reckless driving can lead to accidents. It is the driver's responsibility to drive carefully. This means into account the traffic, road and environmental conditions.
- Be sure to use the same specified type and size of tyre on all 4 wheels. Otherwise, the ASTC may not work correctly.

### CAUTION

- Do not install any aftermarket limited slip differential (LSD) on your vehicle. The active stability control function may stop functioning properly.

### NOTE

- An operation noise may be emitted from the engine compartment in the following situations. The sound is associated with checking the operations of the ASTC. At this time, you may feel a shock from the brake pedal if you depress it. These do not indicate a malfunction.
  - When the ignition switch is set to the "ON" position or the operation mode is put in ON.
  - When the vehicle is driven for a while after the engine is turned on.
- When the ASTC is activated, you may feel a vibration in the vehicle body or hear a whining sound from the engine compartment. This indicates that the system is operating normally. It does not indicate a malfunction.
- When the anti-lock brake system warning lamp is illuminated, the ASTC is not active.

**NOTE**

- On vehicles with the rear differential lock, the ASTC and ABS functions are suspended while the rear differential lock is activated. ASTC indicator lamp, ASTC OFF indicator lamp and ABS warning lamp are illuminated while these functions are suspended. It does not indicate a problem. When the rear differential lock is disengaged, these lamps go out and function again. Refer to “ABS warning lamp” on page 6-70, “ASTC indicator lamp or ASTC OFF indicator lamp” on page 6-74.

**Active Stability Control function**

E00616901327

The active stability control function is designed to help the driver maintain control of the vehicle on slippery roads or during rapid steering maneuvers. It works by controlling the engine output and the brake on each wheel.

**NOTE**

- The active stability control function does not operate when the drive mode-selector is in the “4L” position (Easy Select 4WD), “4LLc” position (Super Select 4WD II). When the active stability control function is operating with the drive mode-selector in the “2H” or “4H” position (Easy Select 4WD), “2H”, “4H” or “4HLc” position (Super Select 4WD II), setting the drive mode-selector to the “4L” (Easy Select 4WD), “4LLc” position (Super Select 4WD II) position makes the active stability control function deactivate automatically.
- The active stability control function operates at speeds of about 15km/h or higher.
- On vehicles with the rear differential lock, the active stability control function does not operate when the rear differential lock is activated.

**“ASC OFF” switch**

E00639800049

The active stability control function is automatically activated when the ignition switch is turned to the “ON” position or the operation mode is put in ON. You can deactivate the system by pressing down the “ASC OFF” switch for 3 seconds or longer. When the active stability control function is deactivated, the  indicator will turn on. To reactivate the ASC, momentarily press the

“ASC OFF” switch; the  indicator is turned off.

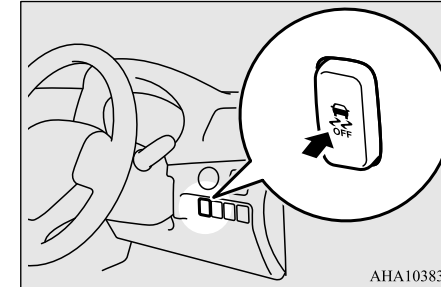

AHA103837

**6****CAUTION**

- For safety reasons, the “ASC OFF” switch should only be operated when the vehicle is stopped.
- Be sure to keep the active stability control function on while driving in normal circumstances.

**Driving hints**

E00616801179

When extricating the vehicle from mud, sand or fresh snow with the drive mode-selector in the “2H” or “4H” position (Easy Select 4WD) or “2H”, “4H” or “4HLc” position (Super Select 4WD II), you may find that operation of the ASTC prevents the engine speed from

## Active Stability & Traction Control (ASTC)\*

increasing in response to depression of the accelerator pedal. If this happens and the vehicle remains stuck as a result, place the drive mode-selector in the “4L” position (Easy Select 4WD), “4LLc” position (Super Select 4WD II), or turn the active stability control switch OFF. The vehicle will then be easier to extricate. (Brake control of the active traction control function is still working to prevent wheel spins when ASC OFF switch “OFF”, “4L” position (Easy Select 4WD) or “4LLc” position (Super Select 4WD II) selected.)

6

### NOTE

- If you continue to press the “ASC OFF” switch after the active stability control function is turned off, the “mistaken operation protection function” will activate and the active stability control function will turn back on.
- Even if the active stability control function is turned off, it may activate depending on the vehicle’s movement.

### Active Traction Control function

E00617001048

On slippery surfaces, the active traction control function prevents the drive wheels from spinning excessive, thus helping the vehicle

to start moving from a stopped condition. It also provides sufficient driving force and steering performance as the vehicle turns while pressing the acceleration pedal.

### CAUTION

- When driving a vehicle on a snowy or icy road, be sure to install snow tyres and drive the vehicle at moderate speeds.

### ASTC indicator lamp or ASTC OFF indicator lamp

E00619301902

The indicator lamps should illuminate when the ignition switch is turned to the “ON” position or the operation mode is put in ON and should go off after a few seconds. If the indicator lamps stay on or do not illuminate when the ignition switch is turned to the “ON” position or the operation mode is put in ON, please contact your nearest authorised MITSUBISHI MOTORS dealer for inspection.



- ASTC indicator lamp  
The indicator lamp will blink when the ASTC is operating.





- ASTC OFF indicator lamp  
This indicator lamp will turn on when the active stability control function is deactivated by either of the following operations:

- The ASC OFF switch is pressed to deactivated the system.
- The drive mode-selector is placed in the “4L” position (Easy Select 4WD) or “4LLc” position (Super Select 4WD II).

### CAUTION

- When  indicator lamp blinks, ASTC is operating, which means that the road is slippery or that your vehicle’s wheels are beginning to slip. If this happens, drive slower with less accelerator input.

**CAUTION**

- If the temperature in the braking system continues to increase due to continuous brake control on a slippery road surface, the warning display will appear and the warning buzzer may sound intermittently to give a warning to the driver. If the driver continues driving even after the warning buzzer sounds and then the temperature is further increased, the  indicator lamp will blink or the warning display will appear again, and the buzzer will sound continuously for several seconds. To prevent the brake system from overheating, the brake control of the active traction control function will be temporarily suspended. At this time, the  indicator lamp blinks slowly. The engine control of the active traction control function and normal brake operation will not be affected. Park your vehicle in a safe place. When the temperature in the braking system has come down, the  indicator lamp will be turned off and the active traction control function will start operating again.



**BRAKE TEMPERATURE HIGH**

**NOTE**

- The  indicator lamp may turn on when you start the engine. This means that the battery voltage momentarily dropped when the engine was started. It does not indicate a malfunction, provided that the indicator lamp goes out immediately.

**NOTE**

- The ASTC function indicator display illuminates only when the 2WD/4WD operation indicator display is selected. (Vehicles equipped with the color liquid crystal display only)

**ASTC function indicator display**

E00647400103

When the ASTC is operating, the indicator display of the wheels that are controlled by the ASTC will blink.

The indicator for the wheel being subjected to antispin control blinks.

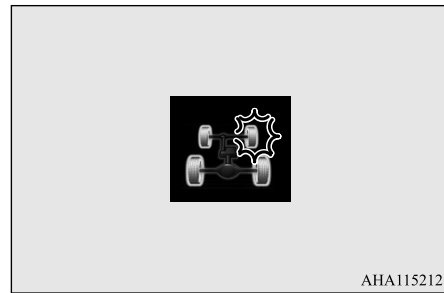

Example indication: ASTC function controlling front-right wheel

**ASTC warning lamp/display**

E00619401873

**6**

If an abnormal condition occurs in the system, the following warning lamp/warning display will turn on.

Warning lamp

 - ASTC indicator lamp

 - ASTC OFF indicator lamp

Warning display

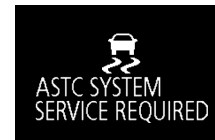



## Cruise control\*

6

### **⚠ CAUTION**

- The system may be malfunctioning. Park your vehicle in a safe place and stop the engine. Restart the engine and check whether the display/indicator lamp goes out. If they go out, there is no abnormal condition. If they do not go out or appear frequently, it is not necessary to stop the vehicle immediately, but we recommend you to have your vehicle inspected.

## Towing

E00624401145

### **⚠ CAUTION**

- If the vehicle is towed with the ignition switch in the “ON” position or the operation mode in ON and only the front wheels or only the rear wheels raised off the ground, the ASTC may operate, resulting in an accident. Refer to “Towing” on page 8-19.

## Cruise control\*

E00609102568

Cruise control is an automatic speed control system that keeps a set speed. It can be activated at approximately 40 km/h or more.

### **⚠ CAUTION**

- When you do not wish to drive at a set speed, turn off the cruise control for safety.
- Do not use cruise control when driving conditions will not allow you to stay at the same speed, such as in heavy traffic or on roads that are winding, icy, snow-covered, wet, slippery, on a steep downhill slope.
- On vehicles with M/T, do not move the gearshift lever to the “N” (Neutral) position while driving at a set speed without depressing the clutch pedal. The engine will run too fast and might be damaged.

### **📖 NOTE**

- Cruise control may not be able to keep your speed on uphill or downhill.
- Your speed may decrease on a steep uphill. You may use the accelerator pedal if you want to stay at your set speed.
- Your speed may increase to more than the set speed on a steep downhill. You have to use the brake to control your speed. As a result, the set speed driving is deactivated.

## Cruise control switches

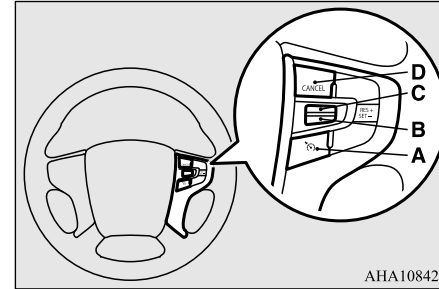

### **A- CRUISE CONTROL ON/OFF switch**

Used to turn on and off the cruise control.

### **B- “SET -” switch**

Used to reduce the set speed and to set the desired speed.

### **C- “RES +” switch**

Used to increase the set speed and to return to the original set speed.

### **D- “CANCEL” switch**

Used to deactivate the set speed driving.

**NOTE**

- When operating the cruise control switches, press the cruise control switches correctly. The set speed driving may be deactivated automatically if two or more switches of the cruise control are pressed at the same time.

**To activate**

E00609302834

1. With the ignition switch in the “ON” position or the operation mode in ON, press the CRUISE CONTROL ON/OFF switch (A) to turn on the cruise control. The indicator lamp/indicator display in the meter cluster will come on.

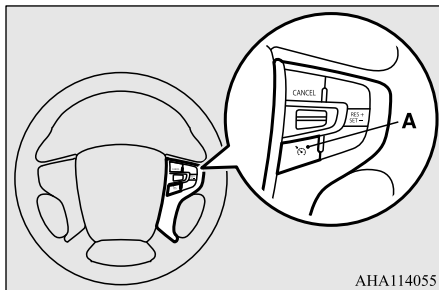

Indicator lamp



Indicator display



2. Accelerate or decelerate to your desired speed, then push down and release the “SET -” switch (B) when the indicator lamp/indicator display is illuminated. The vehicle will then maintain the desired speed. The “SET” indicator appears on the information display in the meter cluster. (For vehicles equipped with color liquid crystal display meter)

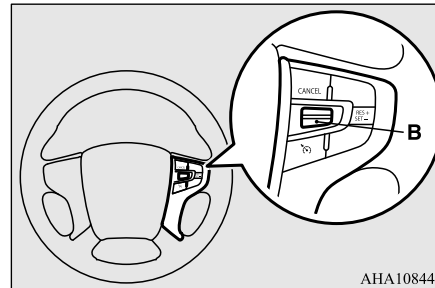

**NOTE**

- When you release the “SET -” switch (B), the vehicle speed will be set.

**To increase the set speed**

E00609401997

There are 2 ways to increase the set speed.

**RES + switch**

Push up and hold the “RES +” switch (C) while driving at the set speed, and your speed will then gradually increase.

When you reach your desired speed, release the switch. Your new cruising speed is now set.

**6**

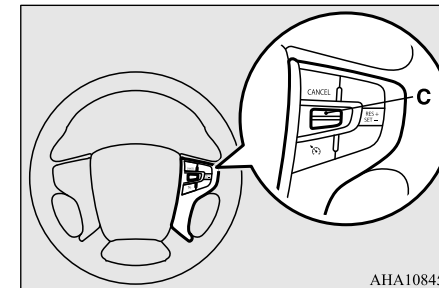

To increase your speed in small amounts, push up the “RES +” switch (C) for less than approximately 1 second and release it. Each time you push up the “RES +” switch (C), your vehicle will go approximately 1.6 km/h faster.

## Cruise control\*

### Accelerator pedal

While driving at the set speed, use the accelerator pedal to reach your desired speed and then push down the “SET -” switch (B) and release the switch momentarily to set a new desired cruising speed.

6

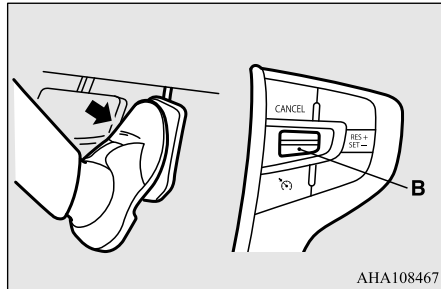

### To decrease the set speed

E00609501927

There are 2 ways to decrease the set speed.

### SET - switch

Push down and hold the “SET -” switch (B) while driving at the set speed, and your speed will slow down gradually.

When you reach your desired speed, release the switch. Your new cruising speed is now set.

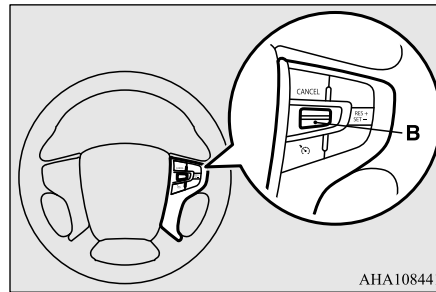

To slow down your speed in small amounts, push down the “SET -” switch (B) for less than approximately 1 second and release it. Each time you push down the “SET -” switch (B), your vehicle will slow down by approximately 1.6 km/h.

### Brake pedal

While driving at the set speed, use the brake pedal, which disengages the cruise control, then push down the “SET -” switch (B) and release the switch momentarily to set a new desired cruising speed.

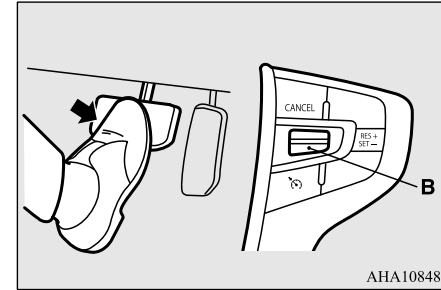

### To temporarily increase or decrease the speed

E00609601478

### To temporarily increase the speed

Depress the accelerator pedal as you would normally. When you release the pedal, you will return to your set speed.

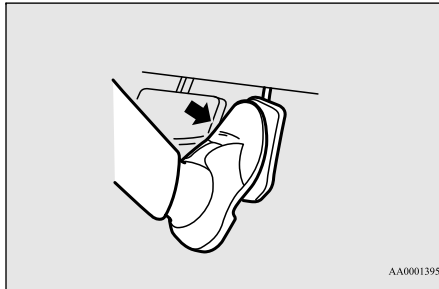

AA0001395

### To temporarily decrease the speed

Depress the brake pedal to decrease the speed. To return to the previously set speed, push up the “RES +” switch (C). Refer to “To resume the set speed” on page 6-80.

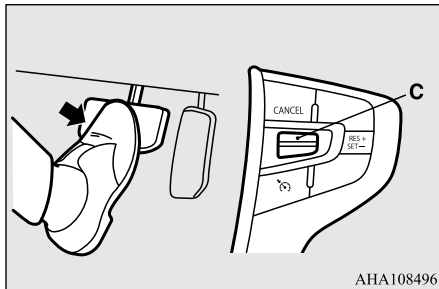

AHA108496

### To deactivate

E00609703082

The set speed driving can be deactivated as follows:

- Press the CRUISE CONTROL ON/OFF switch (A) (Cruise control will be turned off.)
- Press the “CANCEL” switch (D).
- Depress the brake pedal.

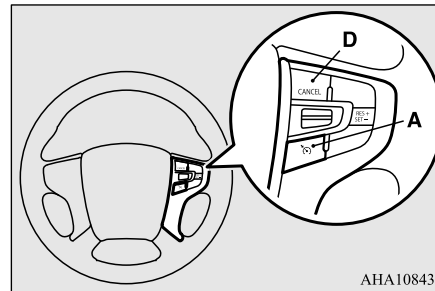

AHA108438

The set speed driving is deactivated automatically in any of the following ways.

- When you depress the clutch pedal (on vehicles with M/T).
- When your speed slows to approximately 15 km/h or more below the set speed because of a hill, etc.
- When your speed slows to approximately 40 km/h or less.

- When the active stability & traction control (ASTC) starts operating. (if so equipped)  
Refer to “Active stability & traction control (ASTC)” on page 6-72.

### ⚠ WARNING

- On vehicles with A/T, although the set speed driving will be deactivated when shifting to the “N” (NEUTRAL) position, never move the selector lever to the “N” (NEUTRAL) position while driving. You would have no engine braking and could cause a serious accident.

6

Also, the set speed driving may be deactivated as follow:

- When the engine speed rises and approaches the tachometer’s red zone (the red-coloured part of the tachometer dial).

### ⚠ CAUTION

- When the set speed driving is deactivated automatically in any situation other than those listed above, there may be a system malfunction.  
Press the CRUISE CONTROL ON/OFF switch to turn off the cruise control and have your vehicle inspected by an authorised MITSUBISHI MOTORS dealer.

## Forward Collision Mitigation system (FCM)\*

### To resume the set speed

E00609802158

If the set speed driving is deactivated by the condition described in “To deactivate” on page 6-79, you can resume the previously set speed by push up the “RES +” switch (C) while driving at a speed of approximately 40 km/h or higher. The “SET” indicator appears on the information display in the meter cluster. (For vehicles equipped with color liquid crystal display meter)

6

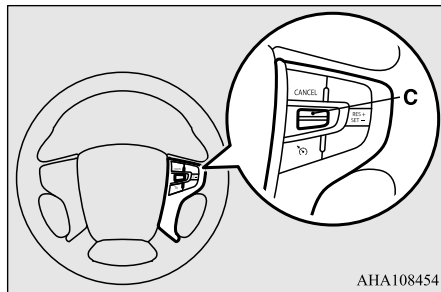

AHA108454

Under either of the following conditions, however, using the switch does not allow you to resume the previously set speed. In these situations, repeat the speed setting procedure:

- The CRUISE CONTROL ON/OFF switch is pressed.
- The ignition switch is turned OFF or the operation mode is put in OFF.

6-80 Starting and driving

- Indicator lamp go off.

### Forward Collision Mitigation system (FCM)\*

E00635101344

The Forward Collision Mitigation system (FCM) uses a sensor (A) to determine the distance and relative speed to a vehicle and a pedestrian in front. When your vehicle is approaching a vehicle or a pedestrian straight-ahead in your path and the FCM judges that there is the risk of a collision, the system will give audible and visual warnings (Forward collision warning function), increases the brake fluid pressure (FCM brake prefill function), and also provides braking force assistance when you depress the brake pedal (FCM brake assist function) to avoid frontal collision.

When the risk of collision increases more, the system judges that a potential collision is imminent, it initiates emergency braking to mitigate collision-caused damages or to avoid possible collision (FCM braking function). Stop lamps are illuminated during automatic braking.

If you turn the FCM ON/OFF, the Ultrasonic misacceleration Mitigation System (UMS)

also turns ON/OFF at the same time. (Vehicles equipped with the UMS)

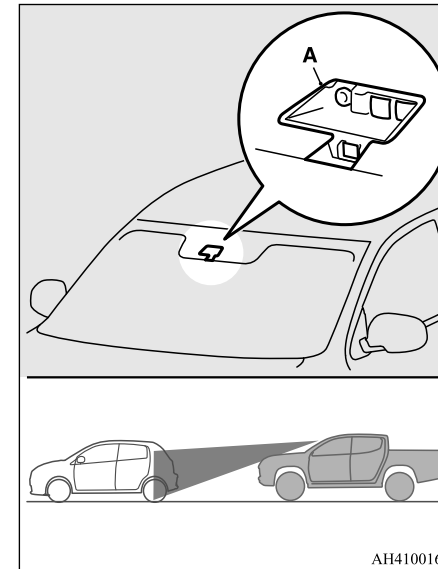

AH4100167

**⚠ WARNING**

- A driver is responsible for driving safely. The FCM is the system to mitigate collision-caused damages or to avoid collisions as much as possible. The system is not intended to compensate for driver's loss of attention to the front during driving due to distraction or carelessness or supplement a drop in visibility due to the rain and fog. It is never a substitute for your safe and careful driving. Always be ready to apply the brakes manually.
- The FCM works to avoid frontal collisions as much as possible. However, the effect of its operation varies depending on situations and conditions, such as driving conditions, road conditions, and steering, acceleration and braking operations, so that the performance the function can deliver is not always the same. If your vehicle is in danger of collision, take all necessary collision-evading actions, such as depressing the brake pedal strongly regardless of whether the system is activated or not.
- Do not try to confirm the operation of the FCM. In certain situations, this can cause an accident resulting in serious injury or death.

**Forward collision warning function**

E00635401217

If the system judges that there is a risk of your vehicle colliding with a vehicle or a pedestrian in front, this function warns you of the potential hazard with visual and audible alarms.

When this function is triggered, a buzzer sounds and, at the same time, a "BRAKE!" message appears on the information screen of the multi information display.

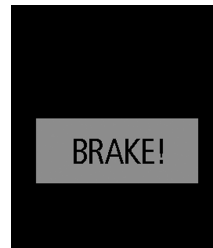

The forward collision warning function operates when the following vehicle speed:

- Against a vehicle: Approximately 15 km/h to 140 km/h.
- Against a pedestrian: Approximately 7 km/h to 65 km/h.

**⚠ CAUTION**

- Under certain conditions, the audible alarm may not work at all or may be scarcely audible. Do not overly rely on the system; if your vehicle is in danger of collision, take all necessary collision-evading actions, such as depressing the brake pedal strongly regardless of whether the system is activated or not.

**FCM brake prefill function**

E00635201042

If the system judges that there is a risk of your vehicle colliding with a vehicle or a pedestrian in front, this function prefills the brake line with additional brake fluid to make the brakes more responsive to your brake pedal operation.

The FCM brake prefill function operates when the following vehicle speed:

- Against a vehicle: Approximately 5 km/h to 80 km/h.
- Against a pedestrian: Approximately 5 km/h to 65 km/h.

**FCM brake assist function**

E00635301069

If the system judges that there is a risk of your vehicle colliding with a vehicle or a

## Forward Collision Mitigation system (FCM)\*

pedestrian in front, this function deploys the brake assist sooner the brake assist operation. The FCM brake assist function operates when the following vehicle speed:

- Against a vehicle: Approximately 15 km/h to 80 km/h.
- Against a pedestrian: Approximately 15 km/h to 65 km/h.

6

### CAUTION

- The brake assist function may not be triggered when the brake pedal is operated in certain ways.  
Do not overly rely on the system; if your vehicle is in danger of collision, take all necessary collision-evading actions, such as depressing the brake pedal strongly regardless of whether the system is activated or not.

### FCM braking function

E00635501869

If the system judges that there is a high risk of your vehicle colliding with a vehicle or a pedestrian in front, the system applies the brakes moderately to encourage you to apply the brakes.

If the system judges that a collision is unavoidable, it initiates emergency braking control to mitigate collision-caused damages or, if the situation permits, to avoid a collision.

6-82 Starting and driving

While the FCM braking control is triggered, you are warned of the hazard with a “BRAKE!” message and audible alarms like with the forward collision warning function. Once the FCM braking has activated, the following message will appear on the information screen of the multi information display.



The FCM braking function operates when the following vehicle speed:

- Against a vehicle: Approximately 5 km/h to 80 km/h
- Against a pedestrian: Approximately 5 km/h to 65 km/h

### CAUTION

- Do not use the FCM as a normal braking.
- After your vehicle has stopped following the activation of the FCM, automatic braking is released. As the vehicle will then start creeping, be sure to depress the brake pedal to hold the vehicle stationary.

### CAUTION

- When applying the brake during the automatic braking condition the pedal will feel firm.  
This is not abnormal.  
You can apply more pressure to the pedal to assist in braking.
- In the following situations, the system provides neither control nor alarming.
  - When a vehicle or a pedestrian suddenly cuts in front of your vehicle.
  - When the distance from a vehicle or a pedestrian in front is extremely short.
  - To an oncoming vehicle.
  - When the selector lever is in the “P” (PARK) or “R” (REVERSE) position (A/T).
  - The gearshift lever is in the “R” (REVERSE) position. (M/T)
  - When the FCM has detected a problem in the system.
- If the ASTC is deactivated, the FCM braking function will not operate. Refer to “Active stability & traction control (ASTC)” on page 6-72.
- The FCM may or may not detect a motorcycle, bicycle or wall depending on the situation. The FCM is not designed to detect these objects.
- The forward collision warning function and/or the FCM braking function may not activate in the following situations.
  - When a vehicle suddenly appears just in front of your vehicle.

- ⚠ CAUTION**
- When a vehicle cuts in front of your vehicle very closely.
  - When the vehicle in front is offset to the left or right.
  - When the vehicle in front is towing a trailer.
  - A freight trailer that is not carrying a container.
  - The vehicle has a protruding load from the carrier.
  - The vehicle has a low vehicle height.
  - The vehicle has an extremely high ground clearance.
  - When a vehicle in front is extremely dirty.
  - When a vehicle in front is covered with snow.
  - When a vehicle in front has a large glass surface.
  - When a vehicle in front does not have reflectors (lamp reflector) or the position of the reflector is low.
  - When a vehicle in front is a car carrier or a similar shaped vehicle.
  - When there is a different object near the vehicle.
  - When driving on a road with many and successive curves, including when passing their entrances and outlets.
  - When accelerating and decelerating quickly.

- ⚠ CAUTION**
- When the system recognizes driver's steering, accelerating, braking or gear shifting actions as evasive actions to avoid collision.
  - When driving on a road with steep and alternating up and down slopes.
  - When driving on a slippery road covered by rain water, snow, ice etc.
  - When a road surface is surging, and there is unevenness.
  - When driving in dark areas, such as in a tunnel or at night.
  - When your vehicle changed lanes, and your vehicle approached immediately behind the vehicle in front.
  - If windscreen wipers are not MITSUBISHI MOTORS GENUINE parts or equivalent.
  - When you are carrying extremely heavy loads in the rear seats or luggage area.
  - After the engine has been running for an extended period of time.
  - When using a windscreen washer.
  - When replacing the windscreen wipers without using the MITSUBISHI MOTORS GENUINE parts.
  - When the sensor becomes extremely hot or cold.
  - If the battery becomes weak or runs down.
  - When the sensor is affected by strong light, such as direct sunlight or the headlamps of an oncoming vehicle.

- ⚠ CAUTION**
- Under adverse weather conditions (rain, snow, sand storms, etc.)
  - When the windscreen of the sensor portion is covered with dirt, water droplets, snow and ice, etc.
  - When water, snow or sand on the road are extorted by the vehicle in front or an oncoming vehicle.
  - The FCM may not detect a pedestrian in certain situations. Some of these include:
    - If the pedestrian is shorter than approximately 1 m or taller than approximately 2 m.
    - If the pedestrian is wearing loose-fitting clothes.
    - If part of a pedestrian's body is hidden, such as when holding an umbrella, large bag, etc.
    - If a pedestrian bends forward, sits or lies on the road.
    - When a pedestrian is pushing/pulling something, such as a stroller, bicycle or wheelchair.
    - When pedestrians gather in a group.
    - When a pedestrian clothing appears to be nearly the same colour or brightness as its surroundings.
    - When a pedestrian is very close to an object, such as a vehicle.
    - When a pedestrian is in a dark area, such as at night or in a tunnel.



## Forward Collision Mitigation system (FCM)\*

6

### ⚠ CAUTION

- When the pedestrian is walking fast or running.
- When a pedestrian suddenly rushes in front of the vehicle.
- When the position of a pedestrian is close to the edge of the vehicle.
- Factors such as the positional relationship between your vehicle and a vehicle in front, driver's own technique of steering the vehicle and irregularly moving traffic due to accidents or vehicle trouble may deter the FCM control and alarm from functioning.
- When the system recognizes driver's steering or accelerating actions as evasive actions to avoid a collision, the FCM control and alarm functions may be cancelled.
- The FCM control and alarm functions may be triggered in the following situations.
  - When there is a structure (B) beside the entrance of a curve and intersection.

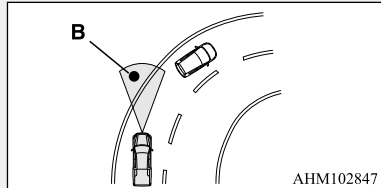

- When running on a narrow iron bridge.
- When passing through a gate with small head or side clearances.
- When there are metallic objects, steps or projections on the road surface.

### ⚠ CAUTION

- When quickly approaching a vehicle in front to overtake it.
- When passing an electronic toll collection gate.
- When running under an overpass, an pedestrian overpass or a small tunnel.
- When running in Multi-storey car park.
- When running the road the gradient changes suddenly.
- When stopping very close to a wall or a vehicle in front.
- When passing close to the vehicle, the pedestrian or an object.

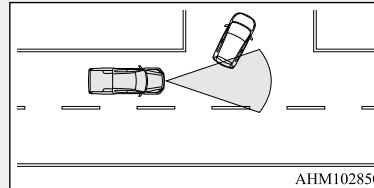

- When driving on the road that the vehicle in front runs in offset position from your vehicle.

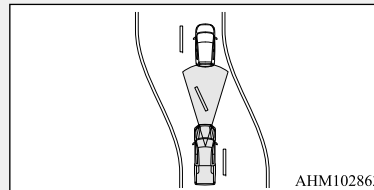

### ⚠ CAUTION

- When passing through an area that objects may contact the vehicle, such as thick grass, tree branches, or a banner.
- When there are patterns on the road that may be mistaken for a vehicle or a pedestrian.
- When a vehicle cuts into your path in the detecting range of the sensor.
- When an oncoming vehicle is positioned straight ahead of your vehicle on a curved road.
- When passing through a plastic curtain etc.
- When the FCM detects a long object carried on your vehicle, such as skies.
- When driving through fog, steam, smoke or dust.
- When the windscreen of the sensor portion is covered with dirt, water droplets, snow and ice, etc.
- Turn off the system beforehand when the vehicle is placed in any of the following situations as the system can operate unexpectedly.
  - When using an automatic car wash.
  - When your vehicle's wheels are driven by the engine on a lift.
  - When your vehicle is towed or your vehicle tows another vehicle.
  - When your vehicle is carried on a truck.
  - When enjoying sports driving on a circuit.
  - When your vehicle is on a chassis dynamometer or free rollers.

**CAUTION**

- When the tyre pressure is not proper.
- When the tyre chains are attached.
- If the windscreen on or surrounding the sensor is cracked or scratched.

**NOTE**

- A sound will be heard during the activation of automatic braking, this is a function of the brake control and is not abnormal.

**FCM and UMS ON/OFF switch**

E00635601453

This switch is used to turn on and off the FCM and UMS and also to select your desired collision alarm timing.

When the switch is held pressed, the ON/OFF state of the FCM and UMS changes from ON to OFF and vice versa. If you give the switch a short press with the FCM in the ON state, you can change the collision alarm timing.

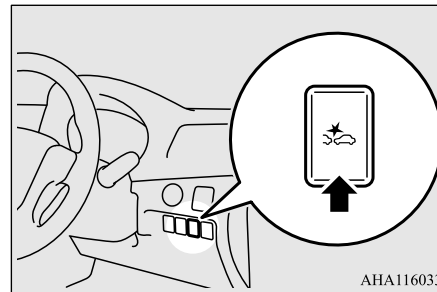

AHA116033

**NOTE**

- When the FCM and UMS ON/OFF switch is held pressed to change the ON/OFF state of the FCM, the ON/OFF state of the UMS is also changed at the same time.

**To turn on/off the system**

You can switch the system from OFF to ON or ON to OFF if you hold the FCM and UMS ON/OFF switch pressed when the operation mode is set to “ON”.

Once the system is turned on, the information screen of the multi information display shows the collision alarm timing currently selected, and the  indicator on the screen goes out.

**6**



When you turn off the system, the following message appears on the screen and the  indicator comes on.



Cycling the operation mode to ON will set the FCM back ON.

## Forward Collision Mitigation system (FCM)\*

### NOTE

- The  indicator is combined with the “UMS OFF” indicator.

### CAUTION

- In the following conditions, even if the FCM is ON, the FCM is automatically switched to OFF. In this case, the warning display may appear if you press the FCM and UMS ON/OFF switch.
  - When the drive mode-selector of Super Select 4WD II is in “4LLc” (if so equipped).
  - When the drive mode-selector of Easy Select 4WD is in “4L” (if so equipped).
  - The rear differential lock is ON (if so equipped).
  - The Hill Descent Control is ON (if so equipped).
  - The ASTC is OFF.

Example: When the drive mode-selector of Super Select 4WD II is in “4LLc”.



6

### To change alarm timing

Give a short press to the FCM and UMS ON/OFF switch to change the timing at which the frontal collision alarm is triggered. Every time you press the switch, the alarm timing changes from three levels, “FAR” (earlier alarming), “MIDDLE” (normally alarming) or “NEAR” (later alarming). As you make selection, the selected alarm timing is displayed on the information screen of the multi information display. Even after turning off the FCM or setting the operation mode to “OFF”, the system retains your last selected alarm timing in memory.

When “FAR” is selected



When “MIDDLE” is selected



When “NEAR” is selected



### CAUTION

- For the FCM brake prefill, the FCM brake assist and the FCM braking functions, the function triggering timing cannot be changed.

### When a problem is detected

E00652100078

When the FCM system determines that its performance has been degraded, the FCM will become inoperative.

This can occur when

- Foreign objects, such as dirt, snow, ice, mist or dew condensation adhere to the windscreen of the sensor portion.
- In adverse weather conditions, such as rain, snow, sand storms, etc.
- A front vehicle or an oncoming vehicle is splashing water, snow or dirt.

## Forward Collision Mitigation system (FCM)\*

“DRIVER ASSISTANCE CAMERA BLOCKED” message will appear and the  indicator will appear on the information screen of the multi information display. When the sensor performance returns, the FCM functions will resume operation. If the display keeps showing the message, there is a possibility that the sensor has a malfunction. Contact an authorised MITSUBISHI MOTORS dealer for inspection of the sensor.



**NOTE**

- The “DRIVER ASSISTANCE CAMERA BLOCKED” message may temporarily appear on the information screen when the sensor cannot detect a vehicle, a pedestrian or an object within range. This is not a malfunction. When a vehicle or an object comes within range, the FCM function will resume and the message will go off.

**NOTE**

- The “DRIVER ASSISTANCE CAMERA BLOCKED” message may appear on the information screen when driving on a non-busy road with a few vehicles and obstacles in front.

If the system becomes temporarily unavailable for some reason, the following message may appear.

The  indicator will appear on the information screen of the multi information display and the FCM will automatically be turned off. If the display keeps showing the message, there is a possibility that the FCM has a malfunction. Contact an authorised MITSUBISHI MOTORS dealer for inspection of the system.

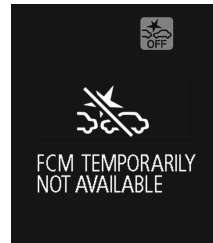

If the system becomes temporarily unavailable due to the high or low temperature of the sensor, the following message will appear.

The  indicator will appear on the information screen of the multi information display and the FCM will automatically be turned off. After the temperature of the sensor has been in range, the system will automatically return to operation.

If the display keeps showing the message, there is a possibility that the FCM has a malfunction. Contact an authorised MITSUBISHI MOTORS dealer for inspection of the system.

**6**



## Forward Collision Mitigation system (FCM)\*

If the FCM detects a malfunction in the system, either of the following messages will appear, the  indicator will appear on the information screen of the multi information display and the FCM will automatically be turned off.

If the message remains even after the operation mode is put in OFF and then turned back to ON, please contact an authorised MITSUBISHI MOTORS dealer.

6



### NOTE

- If the sensor or its surrounding area becomes extremely high temperature when parking the vehicle under a blazing sun, the “FCM SERVICE REQUIRED” message may appear.  
After the temperature of the sensor or its surrounding area has been in range, if the message remains even after restarting the engine, please contact an authorised MITSUBISHI MOTORS dealer.

### Handling of the sensor

E00652200284

The sensor (A) is located inside the windscreen as shown in the illustration.  
The sensor is shared in the following systems:

- FCM
- Automatic High Beam (AHB)

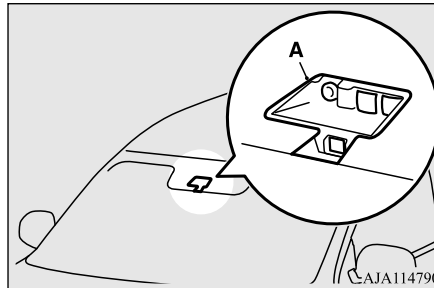

### CAUTION

- To maintain proper performance of the FCM and AHB;
  - Always keep clean the windscreen.  
If the inside of the windscreen where the sensor is installed becomes dirty or fogged, contact an authorised MITSUBISHI MOTORS dealer.
  - Do not apply an impact or load on the sensor or its surrounding area.
  - Do not put anything including a sticker or film to the outer side of the windscreen in front of or surrounding area of the sensor.  
Also, do not put anything including a sticker or film to the inner side of the windscreen under the sensor.

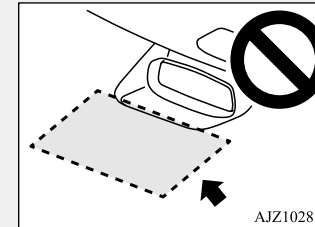

- Do not attempt to detach or disassemble the sensor.
- If the windscreen is misted, remove the mist from the windscreen by using the demister switch.

**⚠ CAUTION**

- Maintain the wiper blades in good condition. Refer to “Wiper blades” on page 9-5. When replacing the wiper blades, use only MITSUBISHI MOTORS GENUINE parts or equivalent.
- Do not dirty or damage the sensor.
- Do not spray glass cleaner on the sensor. Also, do not spill liquid, such as a beverage, to the sensor.
- Do not install an electronic device, such as antenna, or a device that emits strong electric waves, near the sensor.
- Always use tyres of the same size, same type and same brand, and which have no significant wear differences.
- Do not modify the vehicle’s suspensions.
- If the windscreen on the sensor or in the surrounding area of the sensor is cracked or scratched, the sensor may not detect an object properly. This could cause a serious accident. Turn off the FCM and have your vehicle inspected as soon as possible at an authorised MITSUBISHI MOTORS dealer. If you need to replace the windscreen, contact an authorised MITSUBISHI MOTORS dealer.
- The sensor emits infrared rays when the operation mode is in ON. Do not look into the sensor by using optical goods such as a magnifying glass. The infrared ray might injure your eyes.

**Laser radar specifications**

**Laser classification**

Max average power	45 mW
Pulse duration	33 ns
Wavelength	905 nm
Divergent angle (horizon x vertical)	28° x 12°

**Laser classification label**



**Laser explanatory label**

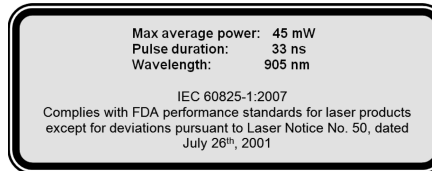

## Ultrasonic misacceleration Mitigation System (UMS)\*

---

### Ultrasonic misacceleration Mitigation System (UMS)\*

E00643400411

The Ultrasonic misacceleration Mitigation System (UMS) operates to prevent sudden starts and mitigate collision-caused damages by suppressing the engine output for up to approximately 5 seconds when the system judges that the system is detected the vehicle or obstacles within approximately 4 m in front and behind your vehicle and judges that accelerator pedal was depressed promptly and too strongly such as misoperation of it. This system operates when the vehicle is at stop or is moving forward or backward at less than approximately 10 km/h.

When the UMS operates, the warning display appears on the information screen of the multi information display, and the buzzer sounds intermittently.

**6**

UMS ON/OFF is switched in conjunction with the ON/OFF state of the Forward Collision Mitigation. (Vehicles equipped with Forward Collision Mitigation system (FCM))

Ultrasonic misacceleration Mitigation System (UMS)\*

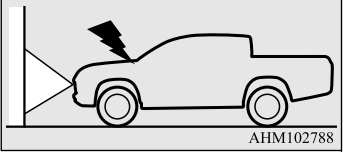
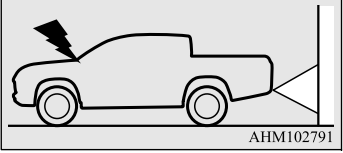
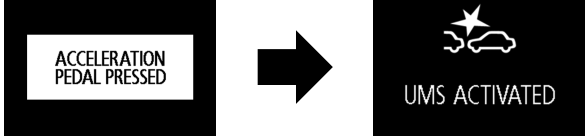
Situation	Operation display	Buzzer
<p>When an obstacle is detected in front of your vehicle with the selector lever in the “D” (DRIVE) position or in the sport mode, if the accelerator pedal is depressed promptly and too strongly, the engine output is suppressed for up to approximately 5 seconds.</p>  <p>AHM102788</p> <p>When an obstacle is detected behind your vehicle with the selector lever in the “R” (REVERSE) position, if the accelerator pedal is depressed promptly and too strongly, the engine output is suppressed for up to approximately 5 seconds.</p>  <p>AHM102791</p>		<p>Intermittent beeping sound</p>

6

**⚠ WARNING**

- Do not overly rely on the UMS. It is never a substitute for your safe and careful driving. Always be careful to operate the accelerator pedal perceiving the environmental conditions. Misoperation can lead to a serious accident.

**⚠ WARNING**

- As the UMS is not a function to keep the stop condition of the vehicle, depress the brake pedal according to the environmental condition.
- Depending on the situation, the system does not operate even if the vehicle or the obstacle in front and behind your vehicle and this may cause the vehicle to start suddenly and lead to a serious accident.

**⚠ WARNING**

- If the vehicle is trapped in the railway crossing because the system is activated as the crossing barrier is misrecognised as an obstacle, escape from the railway crossing without any panic by one of the following methods.
  - Release the foot from the accelerator pedal and lightly depress the pedal again.



## Ultrasonic misacceleration Mitigation System (UMS)\*

6

### WARNING

- Turn the system OFF. (Continuously press the FCM and UMS ON/OFF switch for more than 3 seconds.)
- Continuously depress the accelerator pedal for more than 5 seconds.
- Repeat to press the accelerator pedal quickly to its full stroke more than 3 times.
- Do not perform inspection of the system operation on your own. Depending on the situation, this may cause the system to not operate properly and lead to a serious accident.

### CAUTION

- The UMS does not operate in the following conditions:
  - The ignition switch or the operation mode is other than ON.
  - The UMS is set to OFF by operating the FCM and UMS ON/OFF switch.
  - The FCM and UMS OFF indicator lights up.
  - The selector lever is set to the “P” (PARK) or “N” (NEUTRAL) position.
- It sometimes happens that a motorcycle, bicycle or pedestrian are detected as obstacles, but these are not the object of the UMS operation.
- The UMS may not operate in the following conditions.

### CAUTION

- The sensors or surroundings have been wiped by hand.
- The stickers or accessories have been attached to the sensors or surroundings.
- When there is an extremely change in the outside temperature.
- Under adverse weather conditions (rain, strong winds, snow, sand storms, etc.)
- When approaching an obstacle too closely.
- When a vehicle cuts in front or behind your vehicle very closely.
- When only a part of the obstacle is within the detection areas of the sensor.
- When the rain, snow, water or dirt adheres to the sensor.
- When the sensor is extremely hot or cold (while the vehicle is parked for a long period of time under a blazing sun or in cold weather).
- Immediately after engine starting.
- When driving on a road with many and successive curves, including when passing their entrances and outlets.
- When driving on a road with steep and alternating up and down slopes.
- When a road surface is surging, and there is unevenness.
- When the system judges driver’s steering or gear shifting actions as evasive actions to avoid collision.

### CAUTION

- For a short period after the system judges the repeated depression of the accelerator pedal at a few seconds interval as a release operation.
- When the vehicle body is extremely inclined by carrying heavy loads or improper adjustment of the tyre pressure.
- When the driving is unstable due to an accident or trouble.
- The system receives ultrasonic noise from other sources (the horns of other vehicles, motorcycle engines, brakes, radios, pouring rain, splashing water, snow traction device (tyre chains), etc.).
- When the obstacle is not horizontal to the ground or not perpendicular to the vehicle traveling direction.
- The UMS operation can be cancelled when the system judges the handle operation as evasive actions or when the obstacle moves out of the detectable area of the sensor.
- The UMS may be triggered operate in the following situations.
  - When the surrounding vehicle or oncoming vehicle drives blowing up the water, snow or sand on the road.
  - When the rain, snow, water or dirt adheres to the sensor.
  - When there are objects, steps or projections on the road surface.
  - When the parking gate or railway barrier is raised imperfectly.

**⚠ CAUTION**

- When running the road, the gradient changes suddenly.
- When passing through the mass of the steam, fog.
- When driving in close to the vehicle ahead, and when stopping in close to the forward/backward vehicle or a wall.
- When there is an obstacle in a curb or an intersection.
- When passing through a vinyl curtain etc.
- When the surrounding area is overgrown with weeds.
- When leaving from a parallel parking.
- When there is a ultrasonic near your vehicle by horn of other vehicle, engine sound of a motorcycle, air brake noise of a large vehicle, a vehicle detector and sonar of a vehicle etc..
- When an electrical equipment on the market (radio antenna etc.) is installed near the sensor.
- When driving on a gravel road.
- Turn off the system by pressing the FCM and UMS ON/OFF switch beforehand when the vehicle is placed in any of the following situations as the system can operate unexpectedly.
  - When using an automatic car wash.
  - When returning the fallen wheel in a ditch or escaping from mud.
  - When using a vehicle elevator or a multi-storey car park.

**⚠ CAUTION**

- Do not modify the suspension of your vehicle.
- When your vehicle's wheels are driven by the engine on a lift.
- When your vehicle is towed or your vehicle tows another vehicle.
- When your vehicle is carried on a truck.
- When enjoying sports driving on a circuit.
- When your vehicle is on a chassis dynamometer or free rollers.
- When the tyre pressure is not proper.
- When tyre chains are attached.
- Improperly handling the system components may result in such problems as degraded sensor performance and ultimately in an accident.
 

Be sure to take the following precautions to keep the system in good operating conditions.

  - Avoid application of strong shock loads to the sensor.
  - The sensor should be kept clean.
  - Do not cover the sensor with a sticker or anything.
  - Do not modify the suspension of your vehicle.
- If the bumper has been exposed to an impact, the sensors may fail and prevent the system from functioning properly. Have the vehicle inspected at an authorised MITSUBISHI MOTORS dealer.

**Obstacle detection areas**

E00643500021

The detection areas of the front and rear sensors are limited. Moreover, the sensors are unable to detect low or thin objects or objects near the rear bumper. Make sure to check the surroundings as you operate the vehicle in a safe manner.

**6**

**Sensor locations**

E00643600240

There are the sensors (A) on each of 4 places of the front bumper and the rear bumper.

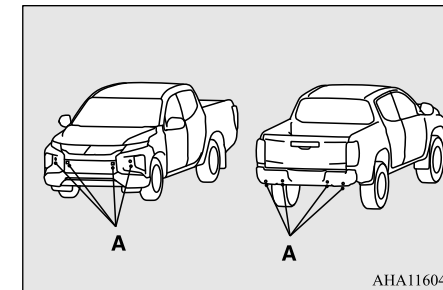

AHA116046

**⚠ CAUTION**

- The UMS may not operate because the sensor cannot detect the vehicle or obstacle as follows.
  - Vehicle towing a trailer etc.

**⚠ CAUTION**

- A freight trailer that is not carrying a container.
- Vehicle that has a protruding load from the carrier.
- Obstacles that have low positions.
- Vehicle that is extremely stained.
- Vehicle or obstacle that is covered with snow.
- A large mesh screen fence.
- Moving object
- When there is a loud noise or a ultrasonic near your vehicle by horn of other vehicle, engine sound of a motorcycle, air brake noise of a large vehicle, a vehicle detector and sonar of a vehicle etc..
- When an electrical equipment on the market (radio antenna etc.) is installed near the sensor.
- The vehicle is the specific shape such as the carrier car.
- Obstacles that have irregular surface.
- Obstacles that have the shape of the pole such as the road marker or the streetlight.
- Obstacles that exists in the high position from the ground.
- Obstacles that are soft and absorb ultrasonic easily, such as spongy material or snow.
- Obstacles that are shaped with a sharp angle.
- A wall surface is not flat

**⚠ CAUTION**

- When there is a obstacle that is not recognized between your vehicle and the obstacle that can be recognized.

**📖 NOTE**

- The sensors do not detect objects located in the area directly below or near the bumper. If the height of an object is lower than the mounted position of the sensors, the sensors may not continue detecting it even if they detected it initially.

**To turn on/off the UMS**

The UMS is automatically turned ON by setting the ignition switch is turned to the “ON” position or the operation mode to ON. In addition, the UMS ON/OFF is switched in conjunction with the ON/OFF state of the FCM. Refer to “FCM and UMS ON/OFF switch” on page 6-85.

**Warning display**

E00643900067

**When the sensor is temporarily not available**

E00647600020

Example: When the front and/or rear sensors are temporarily not available



When the warning display appears, the sensors are temporarily not available for some reason such as the environmental condition or increase of the sensor temperature. When the warning display does not disappear after waiting for a while, contact an authorised MITSUBISHI MOTORS dealer.

**When there is a malfunction in the system or the sensor**

E00644000179

Example: When there is a malfunction in both sensors



When the warning display appears, the UMS does not operate normally because there are some malfunctions in the system or the sensor. Have the vehicle inspected at an authorised MITSUBISHI MOTORS dealer as soon as possible.

#### When the UMS is not available

E00644200139

Example: When trying to set the UMS to ON by pressing the FCM and UMS ON/OFF switch with the rear differential lock ON.

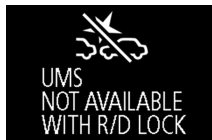

In the following conditions, even if the UMS is ON, the UMS is automatically switched to OFF. In addition, when the UMS is OFF, the UMS is not switched to ON even if the FCM and UMS ON/OFF switch is pressed.

- The drive mode-selector of Super Select 4WD II is in “4LLc” (if so equipped).

- The rear differential lock switch is set to ON (if so equipped).
- The Hill Descent Control is operating (if so equipped).
- The ASTC is set to OFF by operating the ACS OFF switch.

#### Blind Spot Warning (BSW) (with Lane Change Assist)\*

E00644300143

The Blind Spot Warning (BSW) is a driving aid system that alerts the driver when another vehicle which may not be visible through the outside rear-view mirror is travelling in the next lane behind your vehicle.

When a vehicle in the next lane is travelling at same speed or faster in the detection areas, the Blind Spot Warning lamp in the corresponding outside rear-view mirror will illuminate. If the turn-signal lever is operated to the side where the Blind Spot Warning lamp is illuminated, the Blind Spot Warning lamp will blink and the system will beep three times to alert the driver.

Depending on the relative speed between your vehicle and a vehicle in the next lane, the Blind Spot Warning system will detect up to approximately 70 m from your vehicle. (Lane Change Assist)

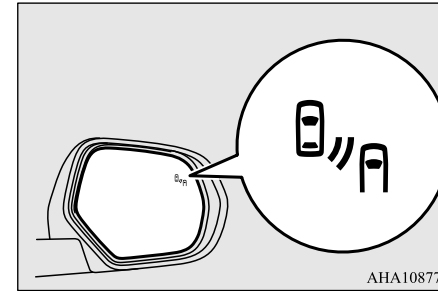

#### WARNING

- Before using the BSW, read this entire section to fully understand the limitations of this system. Failure to follow instructions could result in an accident.
- Never rely solely on the BSW system when changing lanes. BSW is an aid only. It is not a substitute for your safe and careful driving. Always check visually behind and all around your vehicle for other vehicles. The performance of the BSW may vary depending on driving, traffic and/or road conditions.

## Blind Spot Warning (BSW) (with Lane Change Assist)\*

### Detection areas

E00644400362

The BSW uses two sensors (A) located inside the rear bumper.

The detection areas are shown as illustrated.

6

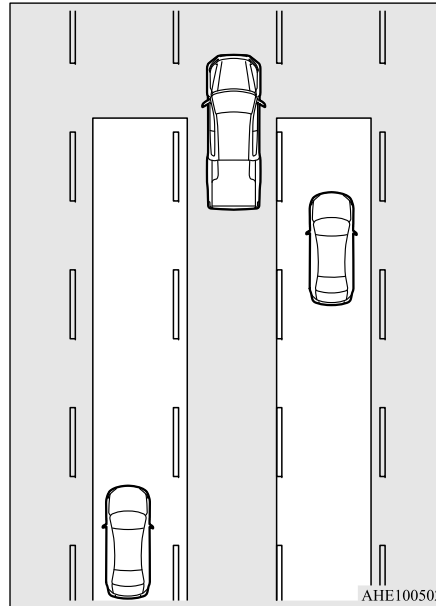
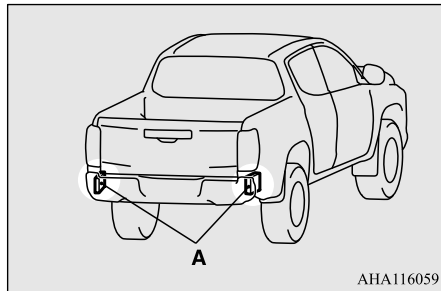

### WARNING

- In certain situations, the BSW may not detect a vehicle in the detection areas or the detection may be delayed. Some of these include;
  - When a small motorcycle or a bicycle is behind your vehicle.
  - When a vehicle is travelling alongside of your vehicle at nearly the same speed for prolonged periods of time.

### WARNING

- When the heights of the next lane and your lane are different.
- Immediately after the BSW has been turned on.
- Immediately after the engine switch is turned on.
- Under adverse weather conditions, such as rain, snow, strong winds or sand storms.
- When your vehicle becomes too close to another vehicle.
- While multiple vehicle are overtaking your vehicle.
- When driving near a pot hole and tram-line.
- When a surrounding vehicle or an oncoming vehicle is splashing water, snow or dirt.
- When driving on a curve including the beginning and the end of the curve.
- When driving on a road with alternating up and down steep slopes.
- When driving on a bumpy or rough road.
- When the rear of your vehicle is weighed down or your vehicle is leaning to the right or left due to the weight of passengers and luggage or the improper adjustment of tyre pressure.
- When the bumper surface around the sensor is covered with dirt, snow and ice, etc.

**⚠ WARNING**

- When the sensor is extremely hot or cold (while the vehicle is parked for a long period of time under a blazing sun or in cold weather).
- When a bicycle carrier or accessory is installed to the rear of the vehicle.

**⚠ CAUTION**

- To maintain proper performance of the BSW, follow the instructions below.
- Always keep the bumper surface around the sensor clean.
- Avoid impacting the sensor or its surrounding area.
- Do not put a sticker on the sensor or its surrounding bumper surface.
- Do not paint the sensor or its surrounding bumper surface.
- Do not modify the sensor or its surrounding area.
- If the bumper has experienced an impact, the sensor may have been damaged and the BSW may not function properly. Have the vehicle inspected at an authorised MITSUBISHI MOTORS dealer.

**To operate**

E00652300272

When the BSW switch is pressed while the ignition switch is turned to the “ON” position or the operation mode is ON, the BSW indicator lamp in the instrument cluster comes on and the BSW becomes in stand by state. When the BSW switch is pressed again, the BSW indicator lamp in the instrument cluster goes off and the BSW turns off.

Indicator lamp

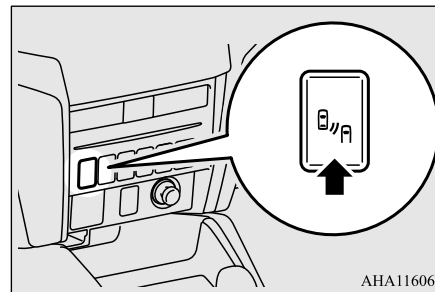

AHA116062

If you turn the BSW ON/OFF, the Rear Cross Traffic Alert (RCTA) also turns ON/OFF at the same time.

**📖 NOTE**

- When the ignition switch is turned to the “LOCK” position or the operation mode is set to OFF, the selected condition just before setting to OFF is retained.
- The BSW operates when all of the following conditions are met.
  - The ignition switch is turned to the “ON” position or the operation mode is put in ON.
  - On vehicles with M/T, the gearshift lever is in a position other than the “R” (Reverse) position.
  - On vehicles with A/T, the selector lever is in positions other than “P” (PARK) and “R” (REVERSE).
  - The speed of your vehicle is approximately 10 km/h or higher.

## Blind Spot Warning (BSW) (with Lane Change Assist)\*

### When the sensor detects an approaching vehicle

When the BSW indicator lamp in the instrument cluster is on, if a vehicle is approaching your vehicle in the detection area, the Blind Spot Warning lamp in the outside rear-view mirror illuminates.

6

If the turn-signal lever is operated to the side where the Blind Spot Warning lamp is illuminated, the Blind Spot Warning lamp will blink and the system will beep three times to alert the driver.

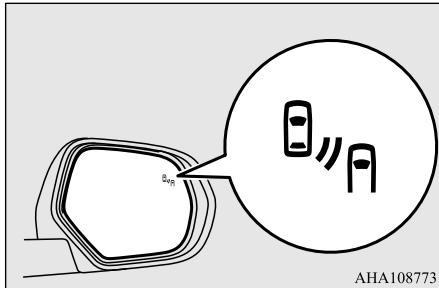

#### NOTE

- The Blind Spot Warning lamp in the outside rear-view mirror may come on or blink in the following conditions.
- When driving very near the guardrail or the concrete wall.

#### NOTE

- When driving on the entrance and outlet of the tunnel or very near the wall or near the evacuation area inside the tunnel.
- When turning at an intersection in a town area.
- Under adverse weather conditions (rain, snow, sand storms etc.).
- When your vehicle drives with blowing up the water, snow or sand etc. on the road.
- When driving near a curb, pot hole and tramline.
- Set the BSW to OFF when towing.
- The Blind Spot Warning lamp in the outside rear-view mirror may not be visible due to strong direct sunlight or the glare from the headlamps of vehicles behind you during night driving.
- Close the rear gate while driving the vehicle. If the rear gate opens while driving the vehicle, the BSW does not operate normally.

### System problem warning

E00692500029

If a problem occurs with the system, a visual warning specific to the type of the problem is given together with an audible alarm. The warnings are combined with the Rear Cross Traffic Alert (RCTA) system.

### When there is a malfunction in the system or the sensor

E00692600091



When the warning display appears, the BSW does not operate normally because there are some malfunctions in the system or the sensor. Have the vehicle inspected at an authorised MITSUBISHI MOTORS dealer as soon as possible.

#### NOTE

- When the warning display appears, the BSW will be deactivated.

### When the sensor is temporarily not available

E00692700092



When the warning display appears, the sensor is temporarily not available for some reason such as the environmental condition or increase of the sensor temperature. When the warning display does not disappear after waiting for a while, contact an authorised MITSUBISHI MOTORS dealer.

### When there is a foreign object on the sensor

E00692800152



When the warning display appears, the sensor cannot detect a vehicle travelling side by side or an approaching vehicle, because foreign objects, such as dirt, snow or ice, adhere to the bumper surface around the sensor. Remove a dirt, freezing or foreign material on the bumper surface around the sensor. When the warning display does not disappear after having cleaned the sensor, contact an authorised MITSUBISHI MOTORS dealer.

### Rear Cross Traffic Alert (RCTA)\*

E00652400231

The Rear Cross Traffic Alert (RCTA) is an aid system for backing up. When the RCTA system detects vehicles approaching from sides while your vehicle is reversing, the Blind Spot Warning lamps in outside rear-view mirrors on both sides will blink and a buzzer will sound to alert the driver. A warn-

### Rear Cross Traffic Alert (RCTA)\*

ing message will also appear on the information screen of the multi-information display.

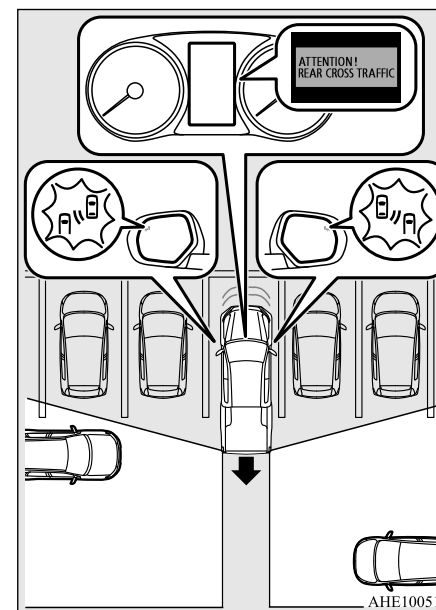

### WARNING

- Before using the RCTA, read this entire section to fully understand the limitations of this system. Failure to follow instructions could result in an accident.



## Rear Cross Traffic Alert (RCTA)\*

6

### WARNING

- Never rely solely on the RCTA when backing up. The RCTA is an aid system. It is not a substitute for your safe and careful driving. Always check visually behind and all around your vehicle for other vehicles, persons, animals or obstructions. The performance of the RCTA may vary depending on driving, traffic and/or surrounding conditions.

### NOTE

- The Blind Spot Warning lamps in the outside rear-view mirrors on both sides will blink, even when only one vehicle is approaching from one side.

### Detection areas

The detection area is shown as illustrated.

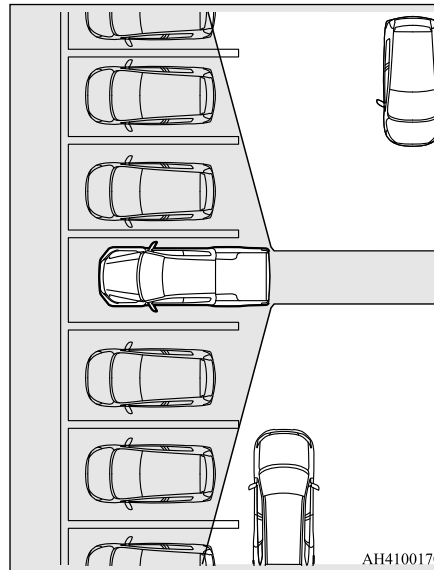

### CAUTION

- In certain situations, the RCTA may not detect a vehicle in the detection areas. Some of these situations include;
  - When the reversing speed of your vehicle is approximately 18 km/h or higher.

### CAUTION

- When an approaching vehicle speed is approximately 7 km/h or less.
- If the sensor detection area is blocked by a nearby object, such as wall or parked vehicle.
- When a vehicle is approaching from straight behind your vehicle.
- When your vehicle is exiting from an angled parking spot.

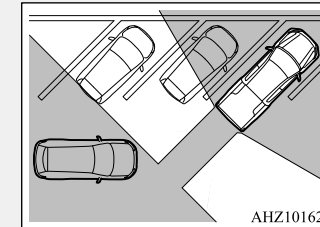

- Immediately after the RCTA has been turned on.
- Immediately after the operation mode has been put in ON.
- When the bumper surface around the sensor is covered with dirt, snow and ice, etc.
- When the sensor becomes extremely hot or cold, such as after the vehicle has been parked for a prolonged time under the blazing sun or in cold weather.
- If the bumper has experienced an impact, the sensor may have been damaged and the RCTA may not function properly. Have the vehicle inspected at an authorised MITSUBISHI MOTORS dealer.

## To operate

1. Press the BSW switch while the operation mode is put in ON.  
(Refer to “Blind Spot Warning (BSW): To operate” on page 6-97.)
2. When the gearshift lever or the selector lever is moved to the “R” (REVERSE) position, the RCTA will operate.

### NOTE

- Set the RCTA to OFF when towing.
- The Blind Spot Warning lamp in the outside rear-view mirror may not be visible due to strong direct sunlight or the glare from the headlamps of vehicles behind you during night driving.
- Close the rear gate while driving the vehicle. If the rear gate opens while driving the vehicle, the RCTA does not operate normally.

## When a problem is detected in the system

If the system detects a problem, a warning is displayed on the information screen in the multi-information display.

Refer to “Blind Spot Warning (BSW): System problem warning” on page 6-98.

## Reversing sensor system\*

E00615501528

This system operates when you are backing the vehicle. It uses corner and back sensors to detect an obstacle and the information screen in the multi information display and the buzzer to inform you of the approximate distance to the obstacle.

### CAUTION

- The reversing sensor system assists you in determining the approximate distance between the vehicle and an obstacle located behind the vehicle. It has limitations in terms of detectable areas and objects, and may not properly detect some objects. Therefore, do not place excessive confidence in the reversing sensor system, and operate the vehicle as carefully as you would a vehicle without this system.
- Make sure to check the surroundings with your own eyes to ensure safety. Do not operate the vehicle by relying on the reversing sensor system alone.

## Obstacle detection areas

E00615601910

The detection areas of the corner and back sensors are limited to those shown in the illustration. Moreover, the sensors are unable

to detect low or thin objects or objects near the rear bumper. Thus, make sure to check the surroundings as you operate the vehicle in a safe manner.

## Corner and back sensor locations

There are four sensors (A) in the rear bumper.

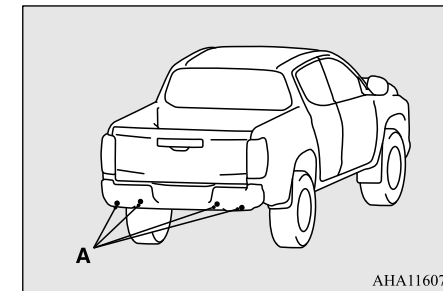

6

## Reversing sensor system detection areas

Depending on whether the vehicle is equipped with a towbar, you can change the reversing sensor system between the standard mode and the towbar mode. The towbar mode changes the system to exclude the area in which the towbar is mounted from the detection areas.

## Reversing sensor system\*

### Vehicles without a towbar

The detection areas are within approximately 60 cm (A) from the corner sensors, 125 cm (B) from the back sensors.

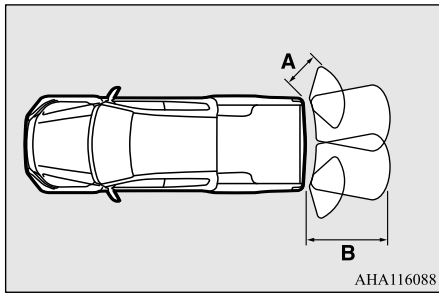

6

### Vehicles with a towbar

The detection areas are within approximately 60 cm (A) from the corner sensors, 125 cm (B) from the back sensors. The non-detection areas (C) are within approximately 20 cm (D) from the bumper.

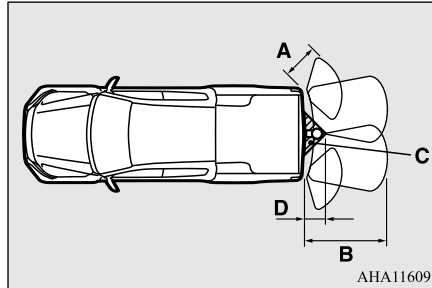

### NOTE

- The sensors do not detect objects located in the area directly below or near the bumper. If the height of an object is lower than the mounted position of the corner or back sensors, the sensors may not continue detecting it even if they detected it initially.

For information on how to change the detection areas, please refer to “Changing the detection areas” on page 6-104.

### CAUTION

- The reversing sensor system may not operate properly under the following conditions:
  - The sensors or surroundings have been wiped by hand.
  - The stickers or accessories have been attached to the sensors or surroundings.
  - The sensors or surroundings are covered with ice, snow, or mud.

### CAUTION

- When there is an extremely change in the outside temperature.
- The sensors are frozen.
- The system receives ultrasonic noise from other sources (the horns of other vehicles, motorcycle engines, brakes, radios, pouring rain, splashing water, snow traction device (tyre chains), etc.).
- The sensors are extremely hot or cold (while the vehicle is parked for a long period of time under a blazing sun or in cold weather).
- The vehicle tilts significantly.
- The vehicle is driven on a rough road (with a bumpy, gravel, hilly, or grassy surface).
- The vehicle is too close to an obstacle.
- Immediately after engine starting.
- The reversing sensor system may not properly detect the following:
  - Objects that are thin, such as wire nets or ropes.
  - Objects that absorb sound waves, such as snow.
  - Objects that are shaped with a sharp angle.
  - Objects with a smooth surface, such as glass.
  - Objects that are low, such as kerbstones.
- If the rear bumper has been exposed to an impact, the corner or back sensors may fail and prevent the system from functioning properly. Have the vehicle inspected at an authorised MITSUBISHI MOTORS dealer.

**NOTE**

- The buzzer may sound lower than the normal warning sound when the reversing sensor system is receiving ultrasonic noise from other sources, but this is not a malfunction. The buzzer will stop sounding and the system will return to normal operation after the noise is no longer received.

**To operate**

E00615702194

To operate the system, the ignition switch is in the “ON” position or the operation mode is put in ON. When the reversing sensor system is operated, the reversing sensor system operation indicator lamp (A) will turn on. To stop the operation, press the “SONAR” switch; the reversing sensor system operation indicator lamp (A) is turned off.

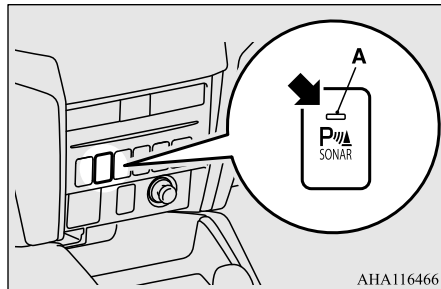

AHA116466

**Warning for obstacles**

If there is an obstacle behind the vehicle, a warning will be issued with the information screen in the multi information display and a warning buzzer.

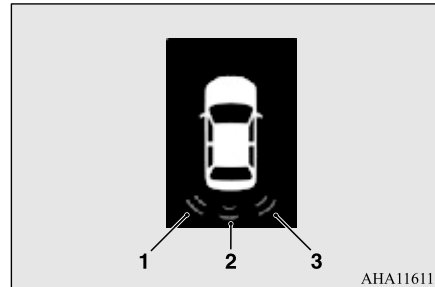

AHA116118

- 1- Corner sensor (left)
- 2- Back sensor
- 3- Corner sensor (right)

**Corner sensor**

Vehicle to obstacle distance	Warning display/sound cycle
Approximately 60 to 40 cm	Intermittent
Approximately 40 to 30 cm	Fast intermittent
Within approximately 30 cm	Continuous

**Back sensor (vehicles without a towbar)**

Vehicle to obstacle distance	Warning display/sound cycle
Approximately 125 to 80 cm	Intermittent
Approximately 80 to 40 cm	Fast intermittent
Within approximately 40 cm	Continuous

**Back sensor (vehicles with a towbar)**

Vehicle to obstacle distance	Warning display/sound cycle
Approximately 125 to 100 cm	Intermittent
Approximately 100 to 60 cm	Fast intermittent
Within approximately 60 cm	Continuous

**6**

**CAUTION**

- The distances given are to be used for reference only, as errors may be caused by various factors, such as temperature, humidity, or the shape of the obstacles.

## Reversing sensor system\*

6

### NOTE

- When the sensors are detecting different obstacles at the same time, the information screen in the multi information display indicates the directions of the obstacles each sensors are detecting. However, closer obstacles are given priority over other detected obstacles and the warning buzzer sounds to inform you of closer obstacles.
- The volume of the warning buzzer can be adjusted.  
For details, consult an authorised MITSUBISHI MOTORS dealer.

### Changing the detection areas

E00615801332

The detection areas can be changed as follows:

#### **Vehicles with a towbar**

While the operation of the system is stopped at the “SONAR” switch, press the “SONAR” switch approximately 3 seconds or more, and release it. The buzzer sounds twice to indicate that the detection area has been changed.

#### **Vehicles without a towbar**

While the operation of the system is stopped at the “SONAR” switch, press the “SONAR” switch approximately 3 seconds or more, and

release it. The buzzer sounds once to indicate that the detection area has been changed.

### NOTE

- The mode of the detection area can be switched only when the gearshift lever or the selector lever is in the “R” (REVERSE) position.
- The detection area will not change if you keep the “SONAR” switch pressed for 10 seconds or more.
- After pressing the “SONAR” switch, reversing sensor system operation differs according to the detection area setting.
  - Setting when towbar is not equipped  
When the gearshift lever or the selector lever is moved to the “R” (REVERSE) position, the reversing sensor system will operate even if corner sensor operation was stopped by pressing the “SONAR” switch.
  - Setting when towbar is equipped  
When reversing sensor system operation was stopped by pressing the “SONAR” switch, the reversing sensor system will not operate until the engine has been stopped even if the gearshift lever or the selector lever is moved to the “R” (REVERSE) position.  
To resume reversing sensor system operation, press the “SONAR” switch or stop and restart the engine, and then move the gearshift lever or the selector lever to the “R” (REVERSE) position.

### Reversing sensor system warning display

E00615901593

In case there is a malfunction in the reversing sensor system, the display for the malfunctioning sensor will blink and the warning buzzer will sound for approximately 5 seconds.

Example: Rear corner sensor (left) malfunctioning



AHA116668

Even after the buzzer and display has stopped warning, the indicator lamp (A) on “SONAR” switch will continue blinking until the system reverts to the normal state. Have the vehicle inspected at an authorised MITSUBISHI MOTORS dealer.

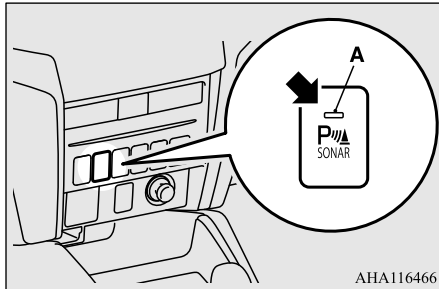

AHA116466

### Sensor system\*

E00647700021

When parking in a garage or during parallel parking, these sensors alert the driver to any objects near the vehicle and their distance, through a buzzer and the sensor display on the information screen in the multi-information display.

### CAUTION

- The sensor system assists you in determining the approximate distance between the vehicle and any objects. It has limitations in terms of detectable areas and objects, and may not properly detect some objects. Therefore, do not place excessive confidence in the sensor system, and operate the vehicle as carefully as you would a vehicle without this system.

### CAUTION

- Make sure to check the surroundings with your own eyes to ensure safety. Do not operate the vehicle by relying on the sensor system alone.

### Obstacle detection areas

E00647800367

The detection areas of the corner and back sensors are limited to those shown in the illustration. Moreover, the sensors are unable to detect low or thin objects or objects near the front or rear bumper. Thus, make sure to check the surroundings as you operate the vehicle in a safe manner.

### Front, corner and back sensor locations

There are 8 sensors (A) in the front and rear bumper.

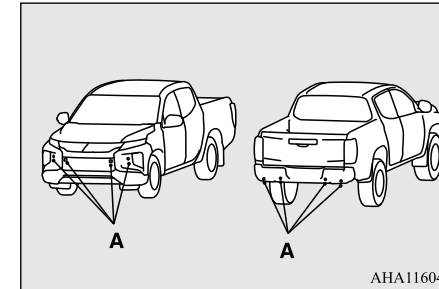

AHA116046

6

### Detection areas

Depending on whether the vehicle is equipped with a towbar, you can change the sensor system between the standard mode and the towbar mode. The towbar mode changes the system to exclude the area in which the towbar is mounted from the detection areas.

#### Vehicles without a towbar

The detection areas are within approximately 60 cm (A) from the front and corner sensors and 125 cm (B) from the back sensors.

## Sensor system\*

6

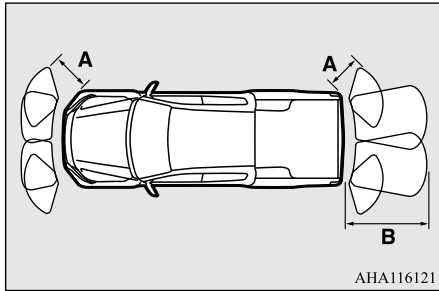

### Vehicles with a towbar

The detection areas are within approximately 60 cm (A) from the front and corner sensors and 125 cm (B) from the back sensors. The non-detection areas (C) are within approximately 20 cm (D) from the bumper.

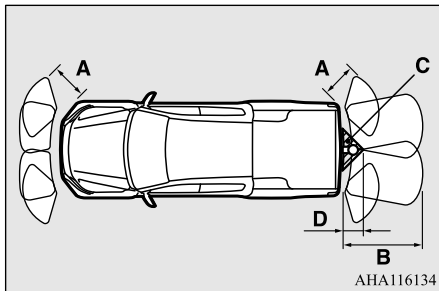

### NOTE

- The sensors do not detect objects located in the area directly below or near the bumper. If the height of an object is lower than the mounted position of the sensors, the sensors may not continue detecting it even if they detected it initially.

For information on how to change the detection areas, please refer to “Changing the detection areas” on page 6-108.

### CAUTION

- The sensor system may not operate properly under the following conditions:
  - The sensors or surroundings have been wiped by hand.
  - The stickers or accessories have been attached to the sensors or surroundings.
  - The sensors or surroundings are covered with ice, snow, or mud.
  - When there is an extremely change in the outside temperature.
  - The sensors are frozen.
  - The system receives ultrasonic noise from other sources (the horns of other vehicles, motorcycle engines, brakes, radios, pouring rain, splashing water, snow traction device (tyre chains), etc.).
  - The sensors are extremely hot or cold (while the vehicle is parked for a long period of time under a blazing sun or in cold weather).

### CAUTION

- The vehicle tilts significantly.
- The vehicle is driven on a rough road (with a bumpy, gravel, hilly, or grassy surface).
- The vehicle is too close to an obstacle.
- Immediately after engine starting.
- The sensor system may not properly detect the following:
  - Objects that are thin, such as wire nets or ropes.
  - Objects that absorb sound waves, such as snow.
  - Objects that are shaped with a sharp angle.
  - Objects with a smooth surface, such as glass.
  - Objects that are low, such as kerbstones.
- If the bumper has been exposed to an impact, the sensors may fail and prevent the system from functioning properly. Have the vehicle inspected at an authorised MITSUBISHI MOTORS dealer.

### NOTE

- The buzzer may sound lower than the normal warning sound when the sensor system is receiving ultrasonic noise from other sources, but this is not a malfunction. The buzzer will stop sounding and the system will return to normal operation after the noise is no longer received.

### To operate

E00648100224

To operate the system, the ignition switch is in the “ON” position or the operation mode is put in ON. When the sensor system is operated, the sensor system operation indicator lamp (A) will turn on. To stop the operation, press the “SONAR” switch; the sensor system operation indicator lamp (A) is turned off.

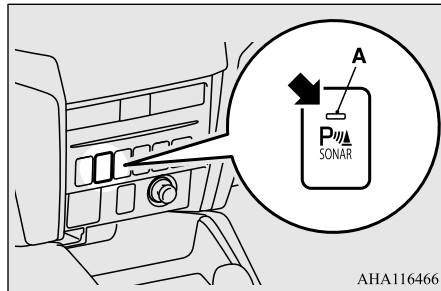

AHA116466

### Warning for obstacles

If there is an obstacle in the vicinity of the vehicle, a warning will be issued with the information screen in the multi information display and a warning buzzer.

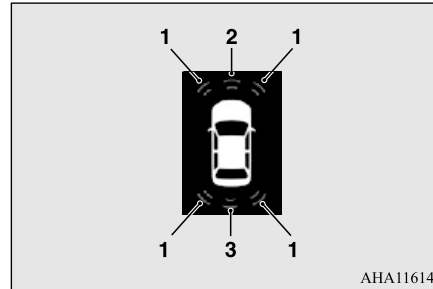

AHA116147

- 1- Corner sensors
- 2- Front sensors
- 3- Back sensors

#### Front and corner sensor

Vehicle to obstacle distance	Warning display/sound cycle
Approximately 60 to 40 cm	Intermittent
Approximately 40 to 30 cm	Fast intermittent
Within approximately 30 cm	Continuous

#### Back sensor (vehicles without a towbar)

Vehicle to obstacle distance	Warning display/sound cycle
Approximately 125 to 80 cm	Intermittent

Vehicle to obstacle distance	Warning display/sound cycle
Approximately 80 to 40 cm	Fast intermittent
Within approximately 40 cm	Continuous

#### Back sensor (vehicles with a towbar)

Vehicle to obstacle distance	Warning display/sound cycle
Approximately 125 to 100 cm	Intermittent
Approximately 100 to 60 cm	Fast intermittent
Within approximately 60 cm	Continuous

#### CAUTION

- The distances given are to be used for reference only, as errors may be caused by various factors, such as temperature, humidity, or the shape of the obstacles.



## Sensor system\*

6

### NOTE

- When the sensors are detecting different obstacles at the same time, the information screen in the multi information display indicates the directions of the obstacles each sensors are detecting. However, closer obstacles are given priority over other detected obstacles and the warning buzzer sounds to inform you of closer obstacles.
- The volume of the warning buzzer can be adjusted.  
For details, consult an authorised MITSUBISHI MOTORS dealer.

### Changing the detection areas

E0064820023

The detection areas can be changed as follows:

#### Vehicles with a towbar

While the operation of the system is stopped at the “SONAR” switch, press the “SONAR” switch approximately 3 seconds or more, and release it. The buzzer sounds twice to indicate that the detection area has been changed.

#### Vehicles without a towbar

While the operation of the system is stopped at the “SONAR” switch, press the “SONAR” switch approximately 3 seconds or more, and

release it. The buzzer sounds once to indicate that the detection area has been changed.

### NOTE

- The mode of the detection area can be switched only when the selector lever is in the “R” (REVERSE) position.
- The detection area will not change if you keep the “SONAR” switch pressed for 10 seconds or more.
- After pressing the “SONAR” switch, sensor system operation differs according to the detection area setting.
  - Setting when towbar is not equipped  
When the selector lever is moved to the “R” (REVERSE) position, the sensor system will operate even if corner sensor operation was stopped by pressing the “SONAR” switch.
  - Setting when towbar is equipped  
When sensor system operation was stopped by pressing the “SONAR” switch, the sensor system will not operate until the engine has been stopped even if the selector lever is moved to the “R” (REVERSE) position.  
To resume sensor system operation, press the “SONAR” switch or stop and restart the engine, and then move the selector lever to the “R” (REVERSE) position.

### Warning display

E00648300213

In case there is a malfunction in the sensor system, the display for the malfunctioning sensor will blink and the warning buzzer will sound for approximately 5 seconds.

Example: Rear corner sensor (left) malfunctioning

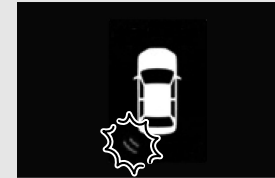

AHA116668

Even after the buzzer and display has stopped warning, the indicator lamp (A) on “SONAR” switch will continue blinking until the system reverts to the normal state. Have the vehicle inspected at an authorised MITSUBISHI MOTORS dealer.

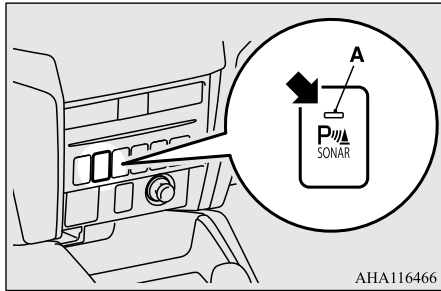

AHA116466

### Range of view of rear-view camera

The range of view of the rear-view camera is limited to the area shown in the illustrations. It cannot show the both sides and the lower part of the rear bumper, etc. When reversing, be sure to visually confirm safety around the vehicle.

### Range of view of rear-view camera

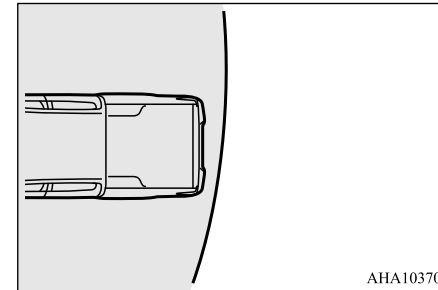

AHA103707

6

### Rear-view camera\*

E00618402873

The rear-view camera is a system that shows the view behind the vehicle on a screen of the Mitsubishi Multi Entertainment System (MMES) or the DVD AUDIO.

### WARNING

- The rear-view camera is an assistance system that enables the driver to check for obstacles behind the vehicle. Its range of view is limited, so you should not overly depend on it. Please drive just as carefully as you would if the vehicle did not have the rear-view camera.
- Be sure to visually confirm safety around the vehicle with your own eyes. Do not depend entirely on the rear-view camera.

### Location of rear-view camera

The rear-view camera (A) is integrated into the part near the rear gate handle.

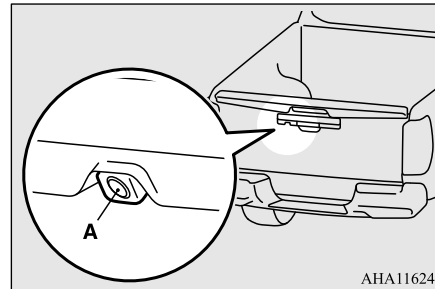

AHA116248

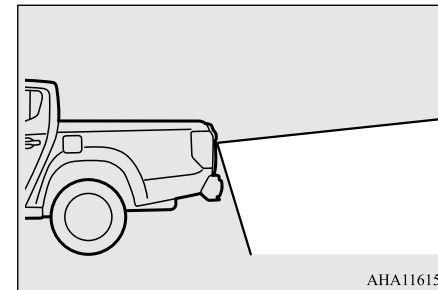

AHA116150

### How to use the rear-view camera

When you place the gearshift lever or the selector lever in the “R” position with the ignition switch in the “ON” position or the

## Rear-view camera\*

operation mode in ON, the view behind the vehicle will automatically appear on the screen of the Mitsubishi Multi Entertainment System (MMES) or the DVD AUDIO. When you move the gearshift lever or the selector lever to any other position, the screen will return to its original indication.

6

### CAUTION

- The rear-view camera has a special lens that can make objects shown on the screen appear to be closer or further away than they actually are.

### NOTE

- Because the rear-view camera has a special lens, the lines on the ground between parking spaces may not look parallel on the screen.
- In the following situations, the screen indication may be difficult to see. There is no abnormality.
  - Low light (nighttime)
  - When the light of the sun or the light from a vehicle's headlamps shines directly into the lens
  - If a fluorescent light shines directly into the lens, the screen indication may be flicker. There is no abnormality.
- If the camera is hot and is then cooled by rain or a car wash, the lens can mist up. This phenomenon does not indicate a malfunction.

### NOTE

- If the atmospheric temperature is extremely hot or extremely cold, the rear-view camera images may not be clear. There is no abnormality.
- If a radio set is installed near the camera, the rear-view camera images may cause electrical system interference and the system may stop functioning properly.
- It is not possible to fully see obstacles when the lens is dirty. If the lens becomes contaminated by water droplets, snow, mud, or oil, wipe off the contamination, taking care not to scratch the lens.
- Please observe the following cautions. Ignoring them could lead to a camera malfunction.
  - Do not subject the camera to physical shock such as striking it strongly or throwing a thing.
  - Do not adhere organic substances, waxes, oil remover, and glass cleaner to the camera. If adhered to them, immediately wipe off.
  - Do not splash the camera with boiling water.
  - Never spray or splash water on the camera or around it.
  - Do not disconnect, disassemble or modify the camera.
  - Do not scratch the camera, as this may cause damage to the rear-view camera images.

### Reference lines on the screen

Reference lines and upper surface of the rear bumper (A) are displayed on the screen.

- Red line (B) indicates approximately 50 cm behind the rear bumper.
- Two Green lines or Yellow (C) indicate approximately 20 cm outside of the vehicle body.
- Short transverse lines (1 to 3) indicate distance from the rear bumper.

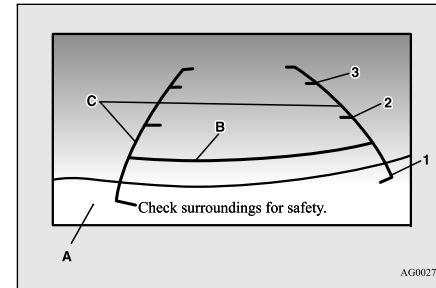

- 1: Approximately at the rear edge of the rear bumper (if so equipped)
- 2: Approximately 100 cm
- 3: Approximately 200 cm

**CAUTION**

- Due to the number of people in the vehicle, the fuel quantity, the weight and positioning of luggage, and/or the condition of the road surface, the lines in the view from the rear-view camera may not be accurately positioned relative to the actual road. Use the reference lines only as a guideline, and always do a safety check of your behind and surroundings directly while driving.

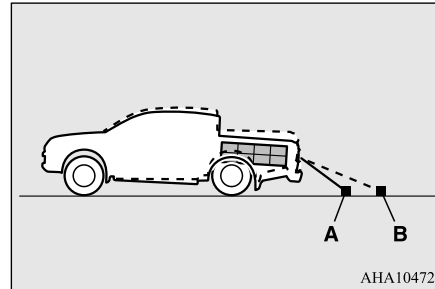

A: Actual objects  
B: Objects shown on the screen

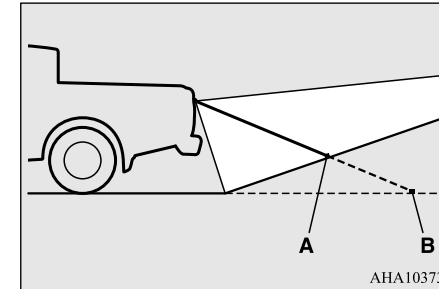

A: Actual objects  
B: Objects shown on the screen

**6**

### Errors between the display and the actual road surface

The reference lines for distance and vehicle width are based on a level, flat road surface. In the following cases, errors are produced between the display reference lines and the distance on the actual road surface.

#### ■ When the rear of the vehicle is weighed down with the weight of passengers and luggage in the vehicle

The reference lines are displayed closer than the actual distance.

Therefore when there is an obstacle on the upward slope, it appears farther than its actual position.

#### ■ When there is an upward slope behind the vehicle

The reference lines are displayed closer than the actual distance.

Therefore when there is an obstacle on the upward slope, it appears farther than its actual position.

#### ■ When there is a downward slope behind the vehicle

The reference lines are displayed farther than the actual distance.

Therefore when there is an obstacle on the downward slope, it appears closer than its actual position.

## Multi Around Monitor\*

6

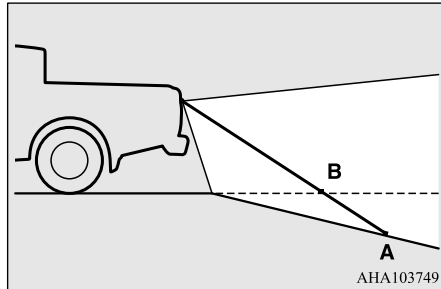

A: Actual objects  
B: Objects shown on the screen

### ■ When solid objects are located close to the vehicle

When solid objects are located close to the vehicle, the displayed distance on the screen may differ from the actual distance.

Because the reference lines do not contact the body of the truck, it looks as if it would not hit the vehicle in following illustration.

However, the vehicle may hit the truck because the body of the truck strays onto the course in reality.

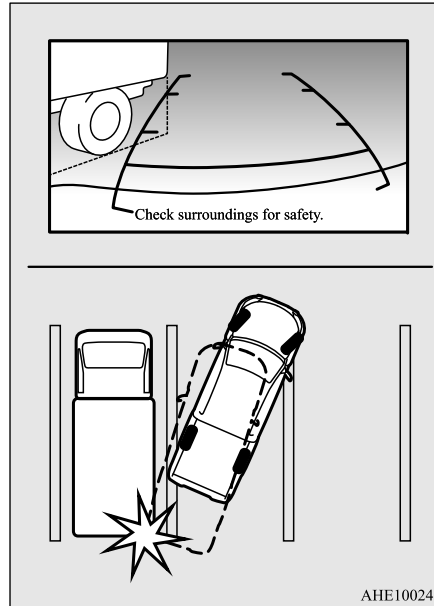

### ■ When approaching to solid objects

The reference lines for distance and vehicle width are intended to indicate the distance to a flat object such as a level, flat road surface. This may make the distance to a projecting object shown on the screen differ from the actual distance to the projecting object. Do

not use them as a guide to distances to solid objects.

Example: On the screen the point B appears the nearest, then the point C and A in order of distance. The point A and B actually are the same distances from the vehicle, and the point C is farther off than the point A and B.

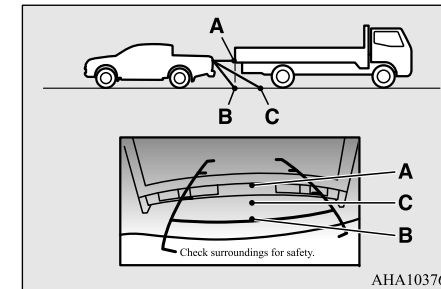

## Multi Around Monitor\*

E00645000495

The Multi Around Monitor is a system that shows the view combined with four cameras, i.e., “Front-view camera”, “Side-view cameras (right and left)” and “Rear-view camera” on a screen of the Mitsubishi Multi Entertainment System (MMES) or the DVD AUDIO. It assists drivers to park their vehicles in parking spaces and to parallel park their vehicles.

**⚠ CAUTION**

- The Multi Around Monitor is an assistance system that enables the driver to check the safety around the vehicle.
- Be sure to visually confirm safety around the vehicle with your own eyes. Especially, the four corners of the vehicle become blind spots where an object is not displayed on the Multi Around Monitor. Do not depend entirely on the Multi Around Monitor.
- Do not use the Multi Around Monitor with the door mirrors retracted in and/or with the doors and/or the rear gate open. It will prevent the Multi Around Monitor from displaying the appropriate range.

**Location of each cameras**

The cameras are integrated into the location as shown below.

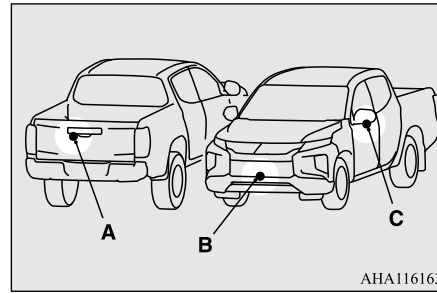

A- Rear-view camera

- B- Front-view camera
- C- Side-view camera

**⚠ WARNING**

- Do not install anything which will disturb the operation of the cameras around the location of them.

**Range of view of the Multi Around Monitor**

The range of view of the Multi Around Monitor cameras is limited to the area shown in the illustrations. It cannot show around the both sides and the lower part of the front and rear bumpers, etc.. While driving, be sure to visually confirm safety around the vehicle.

E00645100454

Multi Around Monitor\*

Range of view of the Multi Around Monitor cameras

6

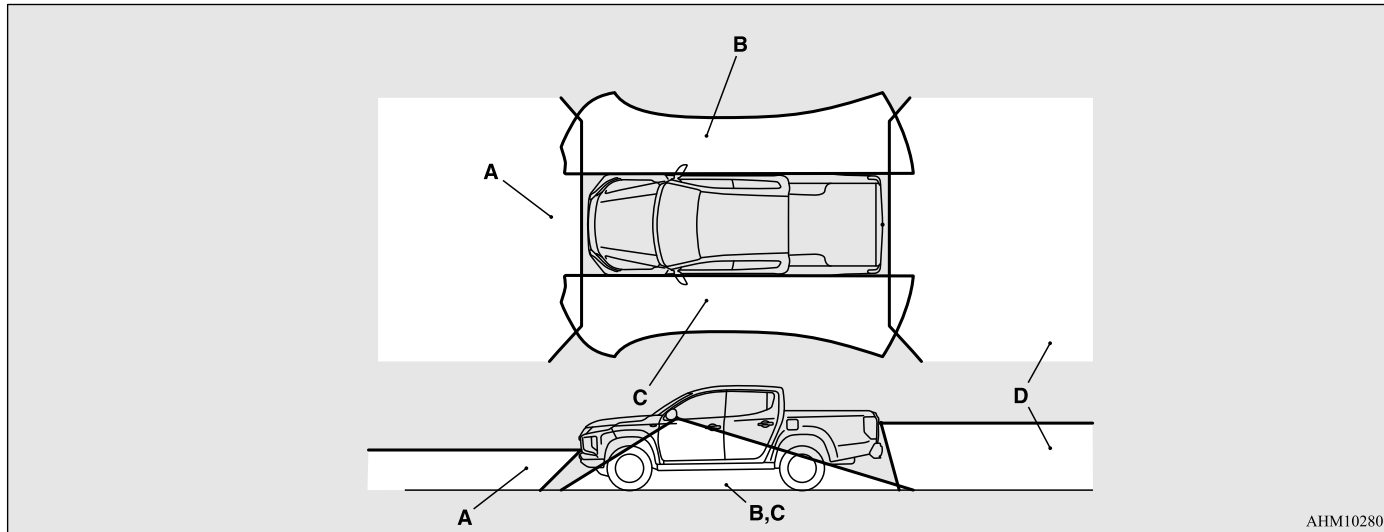

AHM102805

- A: Front-view camera
- B: Side-view camera (Right)
- C: Side-view camera (Left)
- D: Rear-view camera

### Types of views of the Multi Around Monitor

Two different types of views are displayed on the left side and the right side respectively.

#### Bird's eye-view/Rear-view mode

Views of the surroundings of the vehicle and behind the vehicle are displayed.

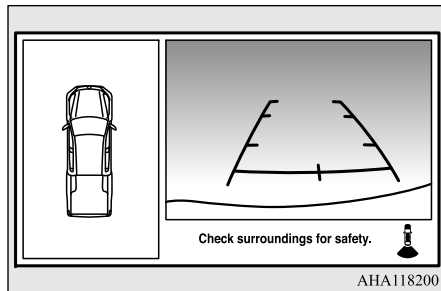

#### Side-view/Rear-view mode

Views of the passenger's side of the vehicle and behind the vehicle are displayed.

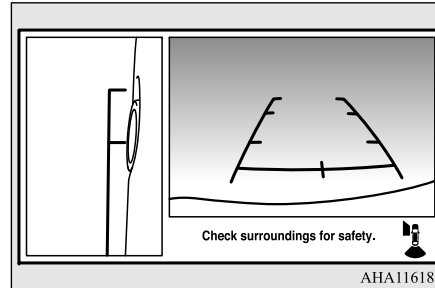

#### Bird's eye-view/Front-view mode

Views of the surroundings of the vehicle and the front of the vehicle are displayed.

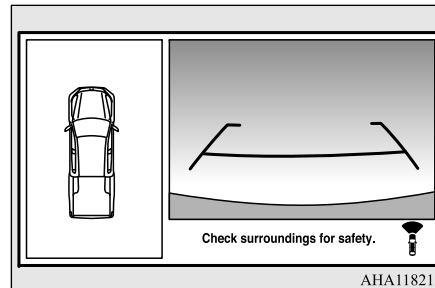

#### Side-view/Front-view mode

Views of the passenger's side of the vehicle and the front of the vehicle are displayed.

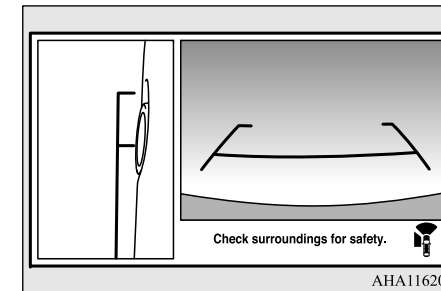

6

#### CAUTION

- The cameras have special lenses that can make objects shown on the screen appear to be closer or further away than they actually are.

#### NOTE

- Because the camera has a special lens, the lines on the ground between parking spaces may not look parallel on the screen.
- In the following situations, the screen indication may be difficult to see. There is no abnormality.
  - Low light (nighttime)



## Multi Around Monitor\*

6

### NOTE

- When the light of the sun or the light from a vehicle's headlamps shines directly into the lens.
- If a fluorescent light shines directly into the lens, the screen indication may be flicker. There is no abnormality.
- If the camera is hot and is then cooled by rain or a car wash, the lens can mist up. This phenomenon does not indicate a malfunction.
- If the atmospheric temperature is extremely hot or extremely cold, the camera images may not be clear. There is no abnormality.
- If a radio set is installed near the camera, the camera images may cause electrical system interference and the system may stop functioning properly.
- It is not possible to fully see obstacles when the lens is dirty. If the lens becomes contaminated by water droplets, snow, mud, or oil, wipe off the contamination, taking care not to scratch the lens.
- Please observe the following cautions. Ignoring them could lead to a camera malfunction.
  - Do not subject the camera to physical shock such as striking it strongly or throwing a thing.
  - Do not adhere organic substances, waxes, oil remover, and glass cleaner to the camera. If adhered to them, immediately wipe off.

### NOTE

- Do not splash the camera with boiling water.
- Never spray or splash water on the camera or around it.
- Do not disconnect, disassemble or modify the camera.
- Do not scratch the camera, as this may cause damage to the camera images.

### How to use the Multi Around Monitor

The Multi Around Monitor can only be used when the ignition switch is in the "ON" position or the operation mode is ON.

### Operation with the gearshift lever or the selector lever

When you place the gearshift lever or the selector lever in the "R" (REVERSE) position, the bird's-eye view/rear view is displayed on the screen of the Mitsubishi Multi Entertainment System (MMES or the DVD AUDIO). When you move the gearshift lever or the selector lever to any other position, the display disappears.

### NOTE

- The passenger's side screen can be switched to the side view by pressing the switch.

### Operation with the switch

When the switch (A) is pressed, the bird's-eye view/front view is displayed.

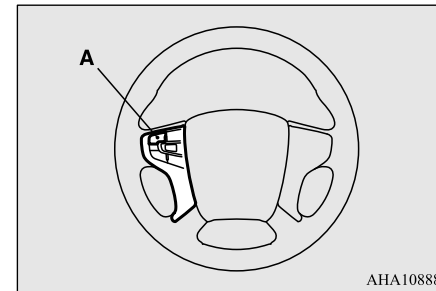

### NOTE

- If there is no operation for 3 minutes after the Multi Around Monitor is displayed by pressing the switch with the gearshift lever or the selector lever in a position other than "R" (REVERSE), the display disappears.

## Switching of the screen

Each time the switch is pressed, the mode of Multi Around Monitor is switched as follows. Bird's eye-view/Front-view mode → Side-view/Front-view mode → Multi Around Monitor is turned OFF.

### NOTE

- When you place the gearshift lever or the selector lever in the "R" (REVERSE) position with the front view displayed on the driver's side screen, the driver's side screen switches to the Rear-view mode. When you move the gearshift lever or the selector lever to any other position, the driver's side screen switches to the Front-view mode.
- When the switch is pressed at the vehicle speed of approximately 10 km/h or higher, only the side view can be displayed on the passenger's side screen.
- The front view will not be displayed when the vehicle speed exceeds approximately 10 km/h.
- The display of the view may be delayed during switching of the screen.

## How to read the screen

E00645400239

In any mode other than the bird's eye-view mode, the lines in the screen give the following information. Use them only as a guide.

### CAUTION

- When you accidentally hit the camera and its circumference against something, the view and the lines in the screen may not be displayed correctly. Be sure to have it inspected by an authorised MITSUBISHI MOTORS dealer.

## Front-view mode

Reference lines for the distance and the vehicle width and upper surface of the front bumper (A) are displayed on the screen.

- The Red line (B) indicates approximately 50 cm from the front edge of the front bumper.
- The Two Green lines (C) indicate the approximate vehicle width.
- The Orange line (D) indicates an expected course when the vehicle moves forward with the steering wheel turned. It disappears when the steering wheel is in the neutral position.

- The approximate distance from the vehicle body is as follows:

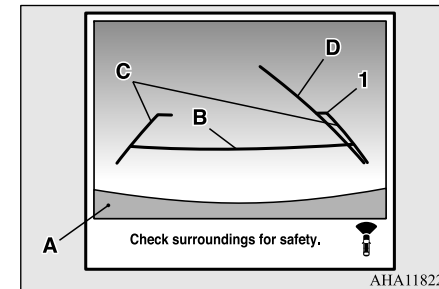

- 1- Approximately 100 cm from the front edge of the front bumper

### NOTE

- When the expected course lines are displayed in the front view, the expected course lines are also displayed in the bird's-eye view (Front: solid line, Rear: broken line).

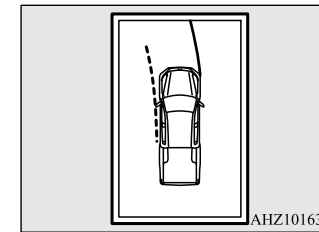

## Multi Around Monitor\*

### Rear-view mode

E00645600244

Reference lines for the distance and the vehicle width and upper surface of the rear bumper (A) are displayed on the screen.

- The Red line (B) indicates approximately 50 cm behind the rear edge of the rear bumper.
- The Two Green lines (C) indicate the approximately vehicle width.
- The Orange line (D) indicates an expected course when the vehicle is reserved with the steering wheel turned. It disappears when the steering wheel is in the neutral position.
- The approximate distance from the vehicle body is as follows:

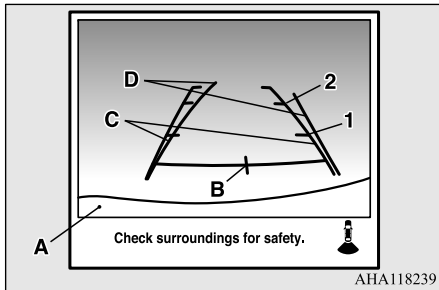

- 1- Approximately 100 cm from the rear edge of the rear bumper

- 2- Approximately 200 cm from the rear edge of the rear bumper

### CAUTION

- Due to the number of people in the vehicle, the fuel quantity, the weight and positioning of luggage, and/or the condition of the road surface, the lines in the view from the rear-view camera may not be accurately positioned relative to the actual road.
- Use the reference lines only as a guideline, and always do a safety check of your behind and surroundings directly while driving.

### NOTE

- When the expected course lines are displayed in the rear view, the expected course lines are also displayed in the bird's-eye view (Front: broken line, Rear: solid line).

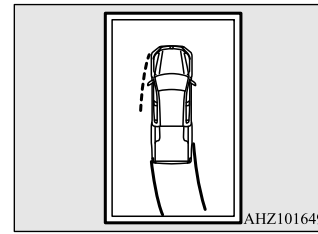

### Errors between the display and the actual road surface

E00645900029

The reference lines for distance and vehicle width are based on a level, flat road surface. In the following cases, errors are produced between the display reference lines and the distance on the actual road surface.

- When the rear of the vehicle is weighed down with the weight of passengers and luggage in the vehicle

E00648600056

The reference lines are displayed closer than the actual distance. Therefore when there is an obstacle on the upward slope, it appears farther than its actual position.

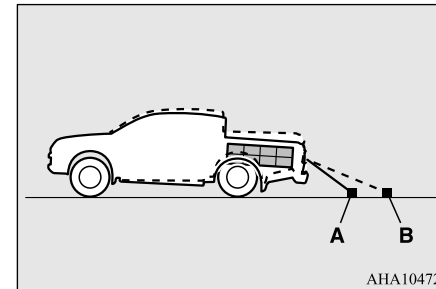

A: Actual objects

B: Objects shown on the screen

**■ When there is an upward slope behind the vehicle**

E00648700057

The reference lines are displayed closer than the actual distance.

Therefore when there is an obstacle on the upward slope, it appears farther than its actual position.

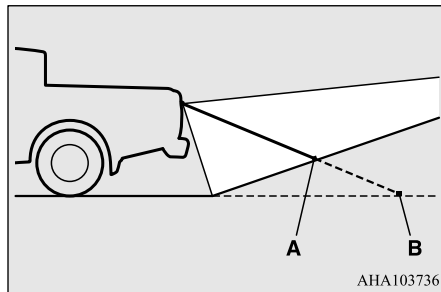

A: Actual objects  
B: Objects shown on the screen

**■ When there is a downward slope behind the vehicle**

E00648800058

The reference lines are displayed farther than the actual distance.

Therefore when there is an obstacle on the downward slope, it appears closer than its actual position.

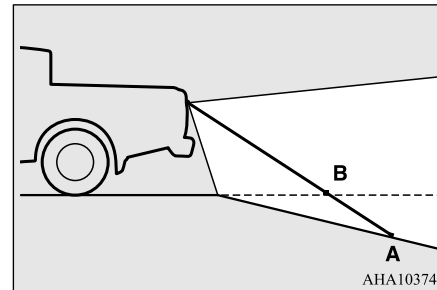

A: Actual objects  
B: Objects shown on the screen

**■ When solid objects are located close to the vehicle**

E00648900059

When solid objects are located close to the vehicle, the displayed distance on the screen may differ from the actual distance.

Because the reference lines do not contact the body of the truck, it looks as if it would not hit the vehicle in following illustration.

However, the vehicle may hit the truck because the body of the truck strays onto the course in reality.

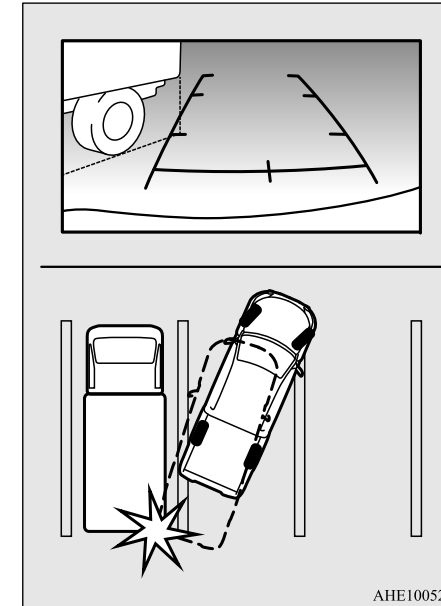

**■ When approaching to solid objects**

E00649000057

The reference lines for distance and vehicle width are intended to indicate the distance to a flat object such as a level, flat road surface. This may make the distance to a projecting object shown on the screen differ from the actual distance to the projecting object. Do

## Multi Around Monitor\*

not use them as a guide to distances to solid objects.

Example: On the screen the point B appears the nearest, then the point C and A in order of distance. The point A and B actually are the same distances from the vehicle, and the point C is farther off than the point A and B.

6

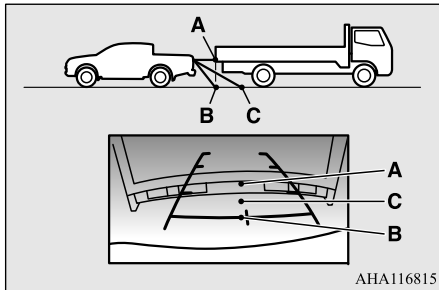

### Side-view mode

E0064610099

Reference lines for the vehicle width and the front end of the vehicle are displayed on the screen.

- 1- Approximately vehicle width including the door mirror.
- 2- Approximately location of the axle centre of the front wheel.
- 3- Approximately 50 cm from the front edge of the front bumper.

6-120 Starting and driving

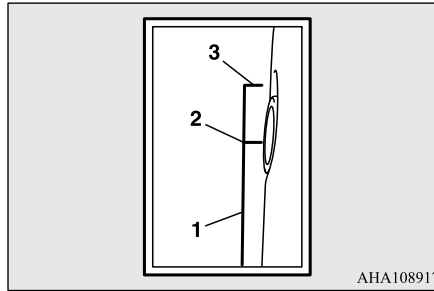

### Bird's eye-view mode

E00646200162

An overhead view in which the vehicle is looked down is displayed so that you can easily identify the location of your vehicle and the course to enter the parking space.

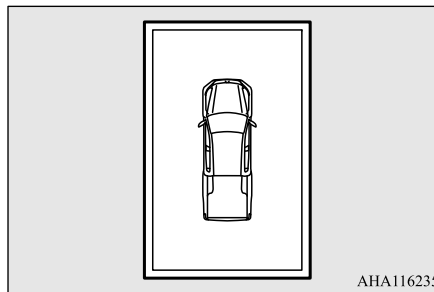

### CAUTION

- The bird's-eye view is an simulated view processed by combining view captured by "Front-view camera", "Side-view cameras (right and left)" and "Rear-view camera". Because of this, in the bird's eye-view mode, objects will appear to be farther away than they actually are. In addition, there are blind spots in the vicinity of the actual vehicle which are not displayed on the screen. You may crash your vehicle even if there seems to be a little distance between your vehicle and an object, and there may be an object in the area where there seems to be nothing. Be sure to check the safety around the vehicle with your own eyes.
- The vehicle icon displayed in the bird's eye-view mode differs from the actual vehicle in colour and size. Because of this, an object near the vehicle may appear to be in contact with the vehicle, and the positional relationship between the vehicle and the object may differ from the actual one.
- The view composition processing regions are present in the four corners of the bird's eye-view display, mainly at the boundary sections of views from each camera. Because of this, in the vicinity of the boundary sections, the sharpness of the views may decrease and an object may disappear and reappear on the screen.

**NOTE**

- In the bird's eye-view mode, since the views captured by the four cameras, "Front-view camera", "Side-view cameras (right and left)" and "Rear-view camera" are processed based on a level flat road surface, an image may be displayed as follows:
  - An object appears to have fallen down and looks longer or larger.
  - An object having a height from the road surface may seem to appear from the joint of the view composition processing regions.
- The brightness of the views from each camera may vary depending on the illuminance conditions.
- An object above the camera is not displayed.
- The object displayed in the Front-view mode or the Rear-view mode may not be displayed in the Bird's eye-view mode.
- The view in the Bird's eye-view mode may be displaced from its true position when the mounting location and angle of each camera are changed.
- The lines on the road may appear to be displaced or bent at the joint of the views.

**To change the vehicle icon colour in the bird's eye-view**

E00693000177

It is possible to change the vehicle icon colour in the bird's eye-view.

1. Stop the vehicle in a safe place.

**CAUTION**

- For reasons of safety, do not operate the switch while driving.

2. Press the switch (A) to display the bird's eye-view/front-view.

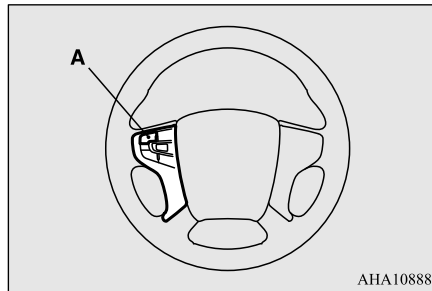

3. Press and hold down the switch (A) until the vehicle icon blinks to enter the selection mode of the vehicle icon colour in the bird's eye-view.
4. Press the switch until the desired colour appears on the display.  
Each time you press the switch, the vehicle icon colour in the bird's eye-view will change to the next one.
5. When it is changed to your desired colour, press and hold the switch (A) for a few seconds. This completes the setting.

**NOTE**

- When the selection mode is in the following situations, the vehicle icon colour does not change.
  - When you place the gearshift lever or the selector lever in the "R" (REVERSE) position.
  - When you do not operate anything for 30 seconds.
  - The ignition switch is turned to the "OFF" position or the operation mode is put in OFF.

**Cargo loads**

E00609902869

**Cargo loads precautions**

**CAUTION**

- When loading luggage, be careful to the following.
  - Stow cargo and luggage in the cargo area whenever possible.
  - Distribute cargo or luggage evenly so that it is not unbalanced.

## Cargo loads

---

### CAUTION

- Do not place cargo or luggage on the instrument panel.  
Also, do not stack up cargo or luggage on the front passenger's seat or the rear seat.  
Having the driver's vision blocked, and your cargo being thrown inside the cabin if you suddenly have to brake can cause a serious accident or injury.

6

## *For pleasant driving*

Ventilators .....	7-2	Listen to MP3s .....	7-51
Cooler* .....	7-4	Listen to an iPod* .....	7-53
Automatic climate control air conditioning* .....	7-7	Listen to Audio Files on a USB Device* .....	7-55
Rear circulator* .....	7-14	Display Indicator .....	7-57
Important air conditioning operation tips .....	7-16	Audio Quality and Volume Balance Adjustment .....	7-59
Air purifier .....	7-16	System Settings .....	7-59
AM/FM radio/CD player with AUX* .....	7-17	Troubleshooting .....	7-60
Handling of Discs .....	7-18	Antenna .....	7-62
Audio Files (MP3/WMA/AAC) .....	7-19	Link System* .....	7-63
Important Points on Safety for the Customer .....	7-23	USB input terminal* .....	7-64
Operation Keys .....	7-23	HDMI terminal* .....	7-66
Listen to Radio .....	7-26	Sun visors .....	7-67
Listen to CDs .....	7-27	Vanity mirror* .....	7-67
Listen to MP3s/WMA/AACs .....	7-28	Ashtray* .....	7-67
Listen to an iPod* .....	7-29	Cigarette lighter* .....	7-68
Listen to Audio Files on a USB Device* .....	7-31	Accessory socket* .....	7-69
Use AUX .....	7-33	USB port (for charging)* .....	7-70
Display Indicator .....	7-34	Interior lamps .....	7-71
Audio Quality and Volume Balance Adjustment .....	7-35	Storage spaces .....	7-73
Time Setting .....	7-35	Cup holder* .....	7-76
Troubleshooting .....	7-36	Bottle holder .....	7-77
AM/FM radio/CD player* .....	7-38	Convenient hook* .....	7-77
Handling of Discs .....	7-41	Assist grip .....	7-77
Audio Files (MP3/WMA/AAC) .....	7-42	Coat hook* .....	7-78
Important Points on Safety for the Customer .....	7-46		
Operation Keys .....	7-46		
Listen to Radio .....	7-49		
Listen to CDs .....	7-51		



## Ventilators

### Ventilators

E00700102061

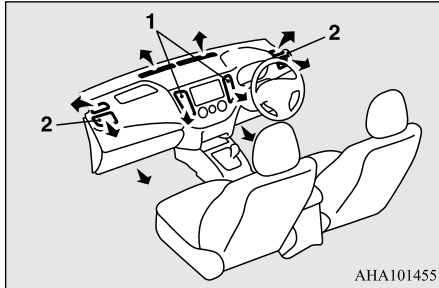

AHA101455

- 1- Centre ventilators
- 2- Side ventilators

#### NOTE

- Do not place beverages on top of the instrument panel. If they splash into the air conditioning ventilators, they could damage the system.

### Air flow and direction adjustments

E00700202453

#### Centre ventilators

Move the knob (A) to adjust the air flow direction.

7-2 For pleasant driving

To close the vent, move the knob (A) to the inside as far as possible.

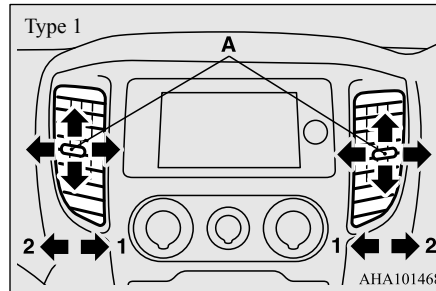

AHA101468

- 1- Close
- 2- Open

#### Side ventilators

Move the knob (A) to adjust the air flow direction.

To close the vent, move the knob (A) to the outside as far as possible.

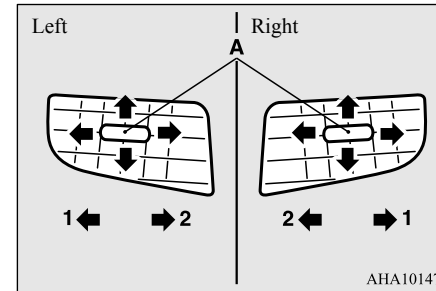

AHA101471

- 1- Close
- 2- Open

#### NOTE

- The cool air from the ventilators may appear as a mist. This is due to moist air being suddenly cooled by the air conditioning. This will clear after a few moments.
- Be careful not to spill beverages, etc., into the ventilators. Doing so might cause the air conditioning not to function normally.

**Mode selection**

E00700302845





To change the position and amount of air flowing from the ventilators, turn the mode selection dial. (Refer to “Mode selection dial” on page 7-5.) On vehicles with the automatic climate control air conditioning, press the MODE switch or demister switch. (Refer to “MODE switch” on page 7-12, “Demister switch” on page 7-13.)

These symbols are used in the next several illustrations to demonstrate the quantity of air coming from the ventilators.

- : Small amount of air from the ventilators
- ↔: Medium amount of air from the ventilators
- ➡: Large amount of air from the ventilators

**The mode selection and air flowing from the ventilators**

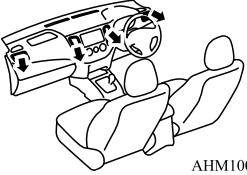
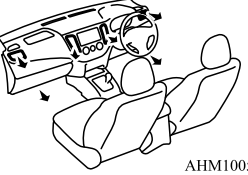
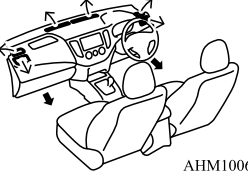
**7**

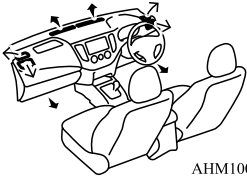
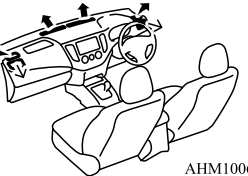
 <b>Face position</b>	 <b>Foot/Face position</b>	 <b>Foot position</b>
 <p>AHM100582</p>	 <p>AHM100595</p>	 <p>AHM100609</p>
 <b>Foot/Demister position*</b>	 <b>Demister position*</b>	
 <p>AHM100612</p>	 <p>AHM100625</p>	

## Cooler\*

### NOTE

- For vehicles with the Auto Stop & Go (AS&G) system, the windows may start to fog up during the Auto Stop & Go (AS&G) system is operating. If this occurs, press the demister switch to remove fog from the windows.

## Cooler\*

7

E00731101073

The cooler can only be used while the engine is running.

### CAUTION

- The engine speed may increase when the air conditioning is operating. With an increased engine speed, an A/T vehicle will creep to a greater degree than with a lower engine speed. Fully depress the brake pedal to prevent the vehicle from creeping.

## Control panel

E00731201087

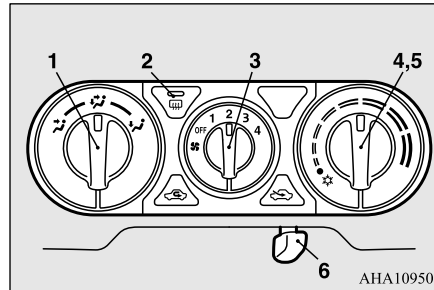

- 1- Mode selection dial
- 2- Rear window demister switch\*  
→ P.5-65
- 3- Blower speed selection dial
- 4- Temperature control dial
- 5- Cooler switch
- 6- Air selection lever

## Blower speed selection dial

E00731301062

Select the blower speed by turning the blower speed selection dial clockwise or anticlockwise.

The blower speed will gradually increase as the dial is turned to the right.

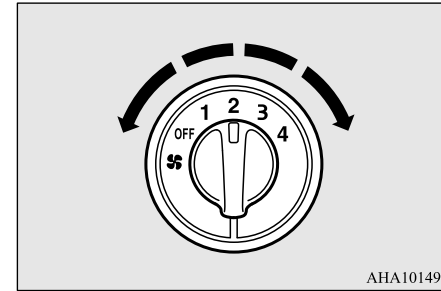

AHA101497

## Temperature control dial/cooler switch

E00731401119

Turn the temperature control dial clockwise to make the air cooler. When the temperature control dial is turned clockwise from “●” position, the air conditioning switch automatically turns “ON”.

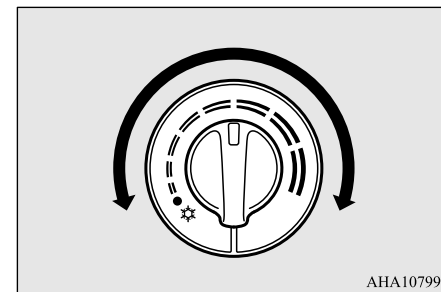

AHA107994

## Mode selection dial

E00731501048

To change the position of air flowing from the ventilators, turn the mode selection dial. (Refer to “Mode selection” on page 7-3.)

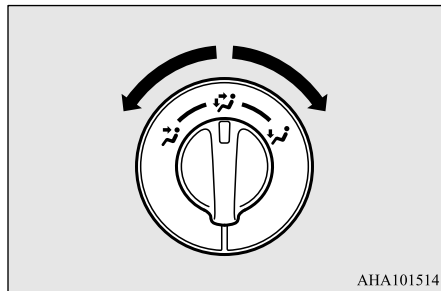

AHA101514

### NOTE

- With the mode selection dial between the “” and “” positions, air flows mainly to the upper part of the passenger compartment. With the mode selection dial between the “” and “” positions, air flows mainly to the leg area.

## Air selection lever

E00731601078

To change the air selection, use the air selection lever.

- “” Outside air  
Outside air is introduced into the passenger compartment.
- “” Recirculated air  
Air is recirculated inside the passenger compartment.

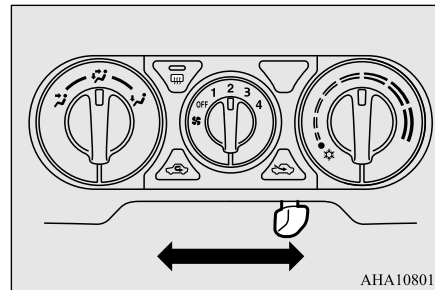

AHA108018

### CAUTION

- Use of the “” (recirculation) position for extended time may cause the windows to fog up.

### NOTE

- Normally, use the “” (outside) position to keep the windscreen and side windows clear and quickly remove fog or frost from the windscreen.  
If high cooling performance is desired, or if the outside air is dusty or otherwise contaminated, use the “” (recirculation) position. Switch to the “” (outside) position periodically to increase ventilation so that the windows do not become fogged up.

7

## Operating the cooler system

E00731700014

### Cooling

E00731801083

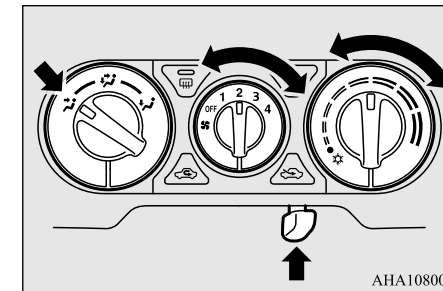

AHA108005

1. Set the mode selection dial to the “” position.

## Cooler\*

---

2. Set the air selection lever to the “

### CAUTION

- If the outside air is dusty or otherwise contaminated, or if high cooling performance is desired, set air selection lever to the “

Switch to the “

7

## Automatic climate control air conditioning\*

E00702402172

The air conditioning can only be used while the engine is running.

### ⚠ CAUTION

- The engine speed may increase when the air conditioning is operating. With an increased engine speed, an A/T vehicle will creep to a greater degree than with a lower engine speed. Fully depress the brake pedal to prevent the vehicle from creeping.

## Control panel

7

E00702503053

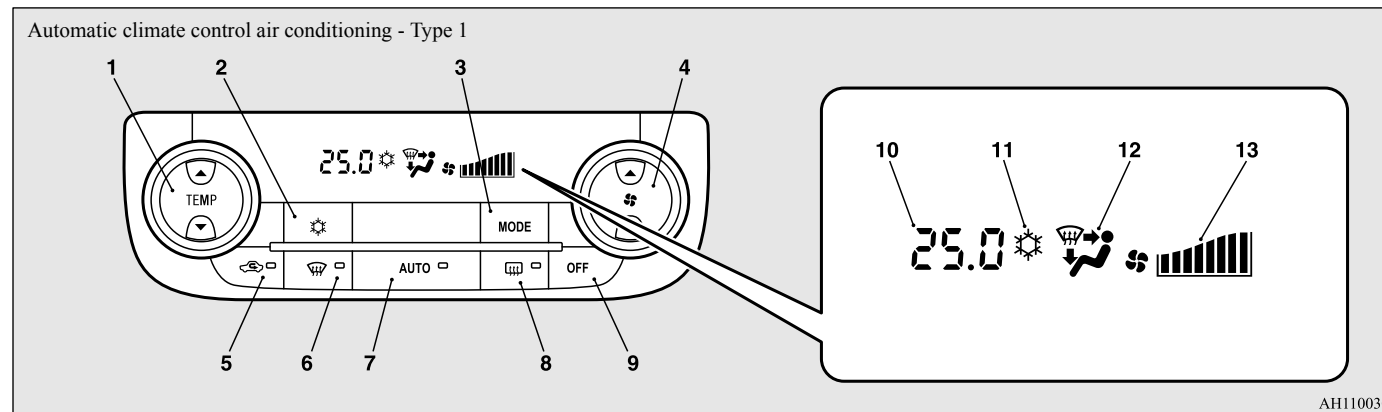

- 1- Temperature control switch
- 2- Air conditioning switch
- 3- MODE switch
- 4- Blower speed selection switch

- 5- Air selection switch
- 6- Demister switch
- 7- AUTO switch

- 8- Rear window demister switch  
→ P.5-65
- 9- OFF switch
- 10- Temperature display → P.7-9

For pleasant driving 7-7

## Automatic climate control air conditioning\*

- 11- Air conditioning indicator
- 12- Mode selection display
- 13- Blower speed display

**7**

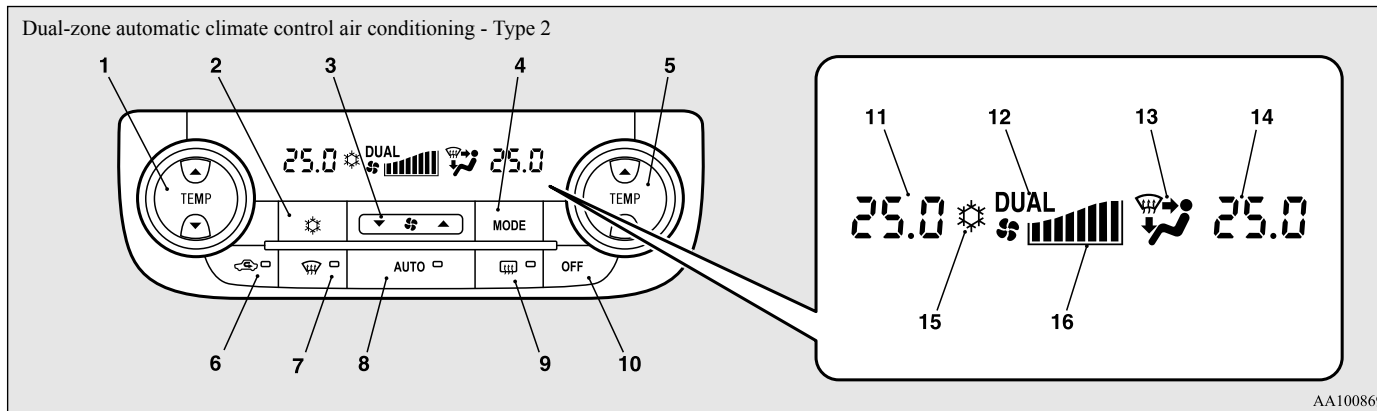

AA1008694

- |  |   |
|--|---|
| 1- Passenger's side temperature control switch | 11- Passenger's side temperature display<br>→ P.7-9 |
| 2- Air conditioning switch                     | 12- DUAL indicator                                  |
| 3- Blower speed selection switch               | 13- Mode selection display                          |
| 4- MODE switch                                 | 14- Driver's side temperature display<br>→ P.7-9    |
| 5- Driver's side temperature control switch    | 15- Air conditioning indicator                      |
| 6- Air selection switch                        | 16- Blower speed display                            |
| 7- Demister switch                             |   |
| 8- AUTO switch                                 |   |
| 9- Rear window demister switch<br>→ P.5-65     |   |
| 10- OFF switch                                 |   |

7-8 For pleasant driving

## Automatic climate control air conditioning\*

### NOTE

- There is an interior air temperature sensor (A) in the illustrated position. Never place anything on top of the sensor, since doing so will prevent it from functioning properly.

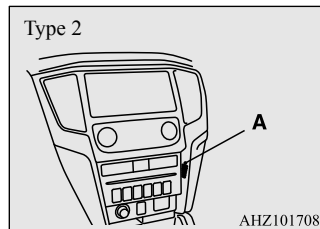
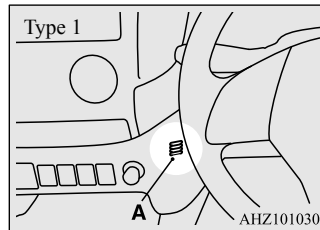

- In extreme cold, the air conditioning control panel screen may operate sluggishly. This does not indicate a problem. It will disappear when the vehicle interior temperature rises to a normal temperature.

### Blower speed selection switch

E00702801427

Press ▲ of the blower speed selection switch to increase the blower speed.  
Press ▼ of the blower speed selection switch to decrease the blower speed.  
The selected blower speed will be shown in the display (A).

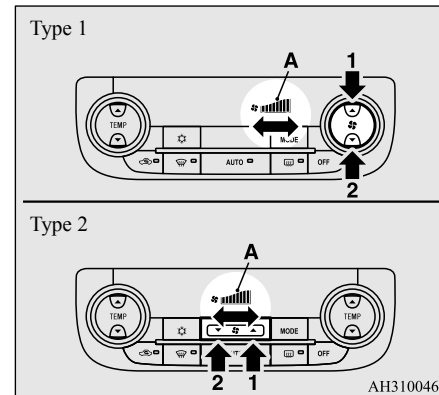

- Increase
- Decrease

### Temperature control switch

E00703002058

Press ▲ or ▼ of the temperature control switch to the desired temperature.

The selected temperature will be shown in the display (A).

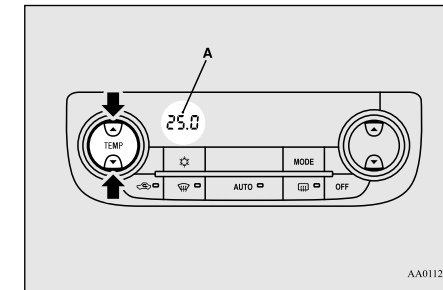

### NOTE

- The temperature value of air conditioning is switched in conjunction with outside temperature display unit of the multi information display.  
On vehicles equipped with multi information display - Type 1, refer to “Changing the temperature unit” on page 5-15. On vehicles equipped with multi information display - Type 2, refer to “Changing the temperature unit” on page 5-26.

7



## Automatic climate control air conditioning\*

### NOTE

- While the engine coolant temperature is low, the temperature of the air from the heater will be cool/cold until the engine warms up, even if you have selected warm air with the switch.  
To prevent the windscreen and windows from fogging up, the ventilator mode will be changed to “” and the blower speed will be reduced while the system is operating in the AUTO mode.
- When the temperature is set to the highest or the lowest, the air selection and the air conditioning will be automatically changed as follows.  
Also, if the air selection is operated manually after an automatic changeover, manual operation will be selected.
  - Quick Heating (When the temperature is set to the highest setting)  
Outside air will be introduced and the air conditioning will stop.
  - Quick Cooling (When the temperature is set to the lowest setting)  
Inside air will be recirculated and the air conditioning will operate.

The settings described above are the factory settings.

The air selection and air conditioning switches can be customised (function setting changed), and the automatic switching of outside air and the air conditioning according to

operating conditions can be changed as desired.

For further information, we recommend you to consult an authorised MITSUBISHI MOTORS dealer.

Refer to “Customising the air conditioning switch” on page 7-12.

Refer to “Customising the air selection” on page 7-11.

### Synchronized mode and dual mode\*

The driver’s side and the passenger’s side temperature can be controlled independently. At this time, the “DUAL” indicator will be shown in the display (A).

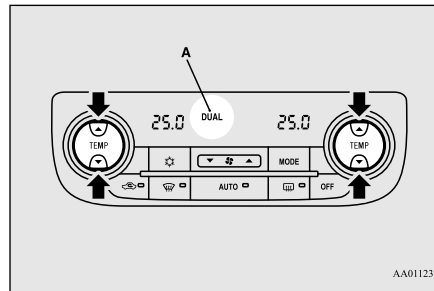

- Synchronized mode

If the driver’s side temperature control switch is pressed, the passenger’s side temperature will also be controlled to the same setting temperature as the driver’s side.

- Dual mode

If the passenger’s side temperature control switch is pressed under synchronized mode, the system will switch to dual mode. In dual mode, the driver’s side and the passenger’s side temperature can be set separately by using each temperature control switch.

Press the AUTO switch to return to synchronized mode.

### Air selection switch

E00703401970

To change the air selection, simply press the air selection switch.

- Outside air: Indicator lamp (A) is OFF  
Outside air is introduced into the passenger compartment.
- Recirculated air: Indicator lamp (A) is ON  
Air is recirculated inside the passenger compartment.

## Automatic climate control air conditioning\*

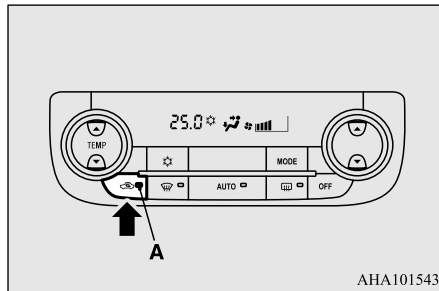

AHA101543

### CAUTION

- Use of the recirculation position for an extended time may cause the windows to fog up.

### NOTE

- Normally, use the outside position to keep the windscreen and side windows clear and quickly remove fog or frost from the windscreen. If high cooling performance is desired, or if the outside air is dusty or otherwise contaminated use the recirculation position. Switch to the outside position periodically to increase ventilation so that the windows do not become fogged up.

### NOTE

- When the engine coolant temperature rises to a certain level, the air selection is automatically switched to the recirculation position and the indicator lamp (A) comes on. At this time, the system will not switch to the outside position even if the air selection switch is pressed.

### Customising the air selection

E00739600048

Functions can be changed as desired, as stated below.

- Enable automatic air control  
When the AUTO switch is pressed, the air selection switch is also controlled automatically.
- Disable automatic air control  
Even when the AUTO switch is pressed, the air selection switch is not controlled automatically.
- Setting change method  
Hold down the air selection switch for about 10 seconds or more.
  - When the setting is changed from enable to disable  
3 sounds are emitted and the indicator lamp flashes 3 times.
  - When the setting is changed from disable to enable

2 sounds are emitted and the indicator lamp flashes 3 times.

### NOTE

- The factory setting is “Enable automatic air control”.
- When the demister switch is pressed, in order to prevent misting of the windows the ventilator automatically switches to outside air even if “Disable automatic air control” is set.

7

### AUTO switch

E00702601193

When the AUTO switch is pressed, the indicator lamp (A) comes on and the mode selection, blower speed adjustment, recirculated/outside air selection, temperature adjustment, and air conditioning ON/OFF status are all controlled automatically.

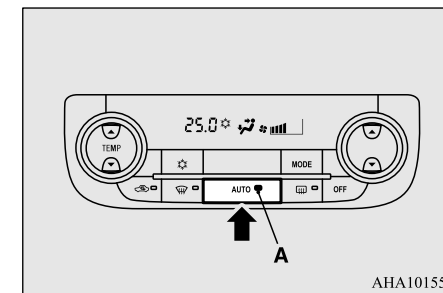

AHA101556

## Automatic climate control air conditioning\*

### Air conditioning switch

E00703502763

Press the switch to turn the air conditioning on, the “” indicator will be shown in the display (A).

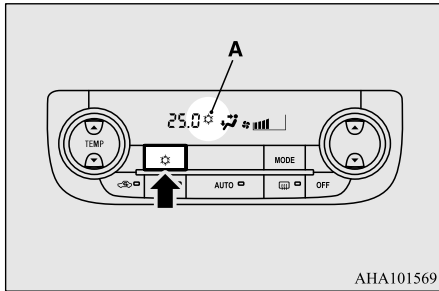

Press the switch again to switch it off.

### ■ Customising the air conditioning switch

E00739700212

Functions can be changed as desired, as stated below.



- Enable automatic air conditioning control  
When the AUTO switch is pressed, or the temperature control switch is set to the minimum temperature, the air conditioning switch is controlled automatically.
- Disable automatic air conditioning control

7-12 For pleasant driving

The air conditioning switch is not controlled automatically as long as the air conditioning switch is not operated.

#### ● Setting change method

Hold down the air conditioning switch for about 10 seconds or more.

- When the setting is changed from enable to disable  
3 sounds are emitted and the “” indicator flashes 3 times.
- When the setting is changed from disable to enable  
2 sounds are emitted and the “” indicator flashes 3 times.

### NOTE

- The factory setting is “Enable automatic air conditioning control”.
- When the demister switch is pressed, in order to prevent misting of the windows the air conditioning operates automatically even if “Disable automatic air conditioning control” is set.

### OFF switch



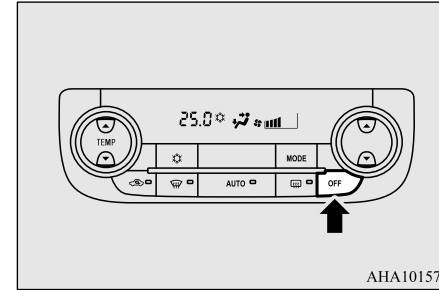

E00702701123

Press the switch to turn off the air conditioning system.



### MODE switch

E00703301041

Each time the MODE switch is pressed, the mode changes to the next one in the following sequence: “” → “” → “” → “” → “”. The selected mode is shown in the display (A). (Refer to “Mode selection” on page 7-3.)

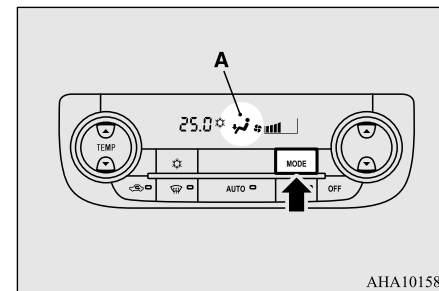

## Demister switch

E00703901092

When this switch is pressed, the mode changes to the “” mode. The indicator lamp (A) will come on. The selected mode is shown in the display (B). (Refer to “Mode selection” on page 7-3.)

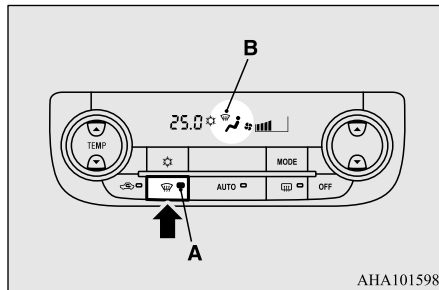

AHA101598

### NOTE

- When the demister switch is pressed, the air conditioning system automatically operates and outside air (as opposed to recirculated air) is selected. This automatic switching control is carried out to prevent misting of the windows even if “Disable automatic air conditioning control” or “Disable automatic air control” is set. (Refer to “Customising the air conditioning switch” on page 7-12, “Customising the air selection” on page 7-11.)

## Operating the system in automatic mode

E00704102838

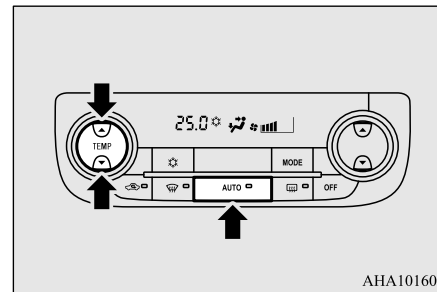

AHA101602

In normal conditions, use the system in the AUTO mode and follow these procedures:

1. Press the AUTO switch.
2. Set the temperature control switch to the desired temperature.

The mode selection, blower speed adjustment, recirculated/outside air selection, temperature adjustment, and air conditioning ON/OFF status are all controlled automatically.

### NOTE

- If the blower speed selection switch, air conditioning switch, MODE switch, or air selection switch is operated while the system is operating in the AUTO mode, the activated function overrides the corresponding function of automatic control. All other functions remain under automatic control.

## Operating the system in manual mode

E00704200239

7

Blower speed and ventilator mode may be controlled manually by setting the blower speed selection switch and the MODE switch to the desired positions.

To return to automatic operation, press the AUTO switch.

## Demisting of the windscreen and door windows

E00704302335

### CAUTION

- For safety, make sure you have a clear view through all the windows.

## Rear circulator\*

### ■ For ordinary demisting

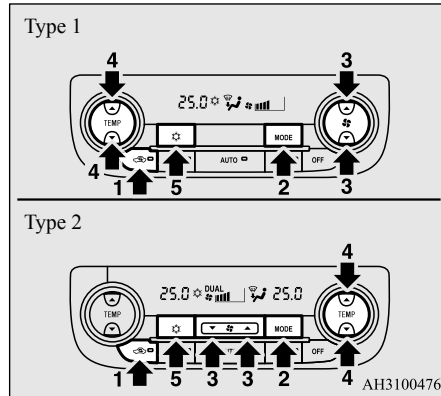

1. Set the air selection switch to the outside position.
2. Set the MODE switch to the “ ” position.
3. Select your desired blower speed by pressing the blower speed selection switch.
4. Select your desired temperature by pressing the temperature control switch.
5. Press the air conditioning switch.

### ■ For quick demisting

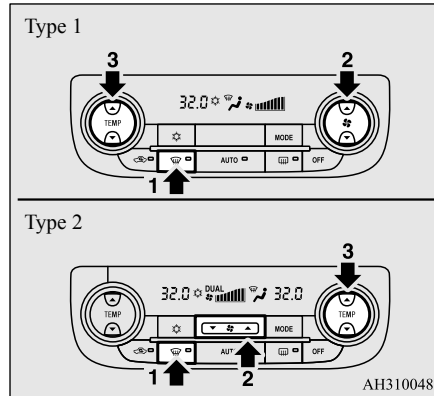

1. Press the demister switch to change to the “ ” position.
2. Set the blower to the maximum speed.
3. Set the temperature to the highest position.

#### NOTE

- To demist effectively, direct the air flow from the side ventilators towards the door windows.
- Do not set the temperature to the max. cool position. Cool air will blow against the window glasses and prevent demisting.

#### NOTE

- For vehicles with the Auto Stop & Go (AS&G) system, if the demister switch is pressed, the Auto Stop & Go (AS&G) system will not operate and the engine will not stop automatically even if the vehicle is stopped. This is to ensure that good visibility is maintained.

## Rear circulator\*

E0077880029

This device circulates air to the rear seat passengers.

The rear circulator can only be used when the ignition switch or the operation mode is in ON or ACC.

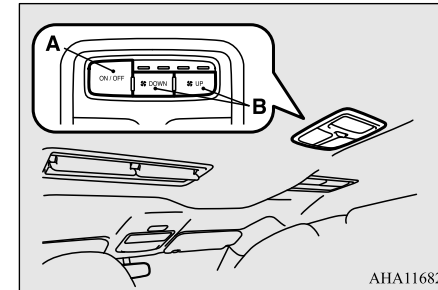

- A- ON/OFF switch  
B- Blower speed adjustment switch

## Air flow and direction adjustments

Move the flap (A) to adjust the air flow direction.

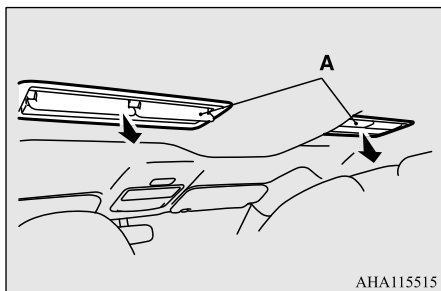

### NOTE

- To send the air flow of the front air conditioning to the rear seat effectively, adjust the centre ventilators to the upper direction.

### NOTE

- Do not put foreign objects into the air inlet port (B).

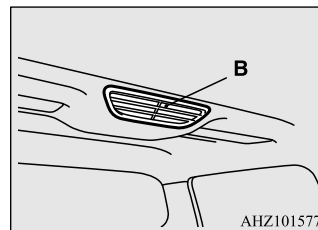

## To operate the rear circulator in the front seat

E00778900020

When the switch is pressed, the fan starts and the indicator lamp (A) comes on. When the switch is pressed again, the fan stops and the indicator lamp goes off.

Rear circulator\*

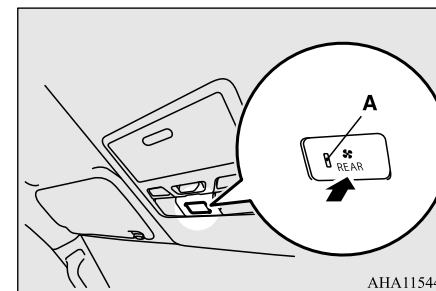

## To operate the rear circulator in the rear seat

E00779000028

1. Press the "ON/OFF" switch to activate the rear circulator.
2. Press the "UP" button to increase the blower speed and press the "DOWN" button to decrease the blower speed. The selected blower speed will be shown with the indicator lamp (A).
3. Press the "ON/OFF" switch again to stop operation.

7

## Important air conditioning operation tips

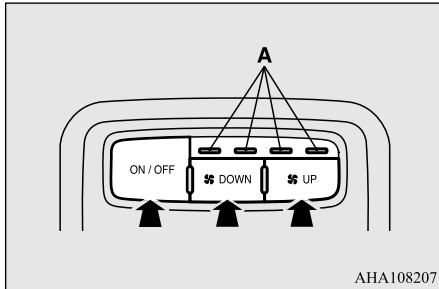

7

### NOTE

- If the rear circulator is activated again after it is stopped by pressing the “ON/OFF” switch or after the ignition switch or the operation mode is OFF, the blower speed will return to the previous setting.

## Important air conditioning operation tips

E00708302649

- Park the vehicle in the shade.  
Parking in the hot sun will make the vehicle inside extremely hot, and it will require more time to cool the interior.  
If it is necessary to park in the sun, open the windows for the first few minutes of air conditioning operation to expel the hot air.

- Close the windows when the air conditioning is in use. The entry of outside air through open windows will reduce the cooling efficiency.
- Too much cooling is not good for the health. The inside air temperature should only be 5 to 6 °C below the outside air temperature.
- When operating the system, make sure the air intake, which is located in front of the windscreen, is free of obstructions such as leaves and snow. Leaves collected in the air-intake plenum may reduce air flow and plug the plenum water drains.

## Air conditioning system refrigerant and lubricant recommendations

If the air conditioning seems less effective than usual, the cause might be a refrigerant leak. We recommend you to have the system inspected.

The air conditioning system in your vehicle must be charged with the refrigerant HFC-134a and the lubricant DH-PR.

Use of any other refrigerant or lubricant will cause severe damage which will result in the need to replace your vehicle’s entire air conditioning system. The release of refrigerant into the atmosphere should be prevented.

It is recommended that the refrigerant be recovered and recycled for further use.

## During a long period of disuse

The air conditioning should be operated for at least five minutes each week, even in cold weather. This is to prevent poor lubrication of the compressor internal parts and to maintain the air conditioning in the best operating condition.

## Air purifier

E00708402044

An air filter has been incorporated into this air conditioning so that dirt and dust are cleaned from the air.

Replace the air filter periodically as its ability to clean the air will be reduced as it collects pollen and dirt. For the maintenance interval, refer to the “SERVICE BOOKLET”.

### NOTE

- Operation in certain conditions such as driving on a dusty road and frequent use of the air conditioning can lead to reduction of service life of the filter. When you feel that the airflow is lower than normal or when the windscreen or windows start to fog up easily, replace the air filter.  
We recommend you to have it checked.

## AM/FM radio/CD player with AUX\*

E00708503547

The audio system can only be used when the ignition switch or the operation mode is in ON or ACC.

### NOTE

- For vehicles equipped with the Keyless operation system, if the operation mode is left in ACC, the accessory power will automatically turn off after a certain period of time and you will no longer be able to use the audio system. The accessory power comes on again if the engine switch is operated with it in the “ACC” position. Refer to “ACC power auto-cutout function” on page 6-15.
- If a cellular phone is used inside the vehicle, it may create noise from the audio equipment. This does not mean that anything is wrong with your audio equipment. In such a case, use the cellular phone at a place as far away as possible from the audio equipment.
- If foreign objects or water get into the audio equipment, or if smoke or a strange odour comes from it, immediately turn off the audio system. We recommend you to have it checked. Never try to repair it by yourself. Avoid continuous usage without inspection by a qualified person.

## Important Points on Usage

E00735500023

### iPod/iPhone Playback Function\*

- This product supports audio playback from iPod/iPhone devices, however differing versions mean that playback cannot be guaranteed.
- Please be aware that depending on the iPod/iPhone model or version, operation may differ.

### How to Clean

E00735700025

- If the product becomes dirty, wipe with a soft cloth.
- If very dirty, use a soft cloth dipped in neutral detergent diluted in water, and then wrung out. Do not use benzene, thinners, or other chemical wipes. This may harm the surface.

### Trademarks

E00735801241

- Product names and other proper names are the trademarks or registered trademarks of their respective owners.

## AM/FM radio/CD player with AUX\*

- Furthermore, even if there is no specific denotation of trademarks or registered trademarks, these are to be observed in their entirety.



“Made for iPod”, “Made for iPhone” mean that an electronic accessory has been designed to connect specifically to iPod or iPhone, respectively, and has been certified by the developer to meet Apple performance standards.

iPhone, iPod, iPod classic, iPod nano, and iPod touch are trademarks of Apple Inc., registered in the U.S. and other countries. Apple is not responsible for the operation of this device or its compliance with safety and regulatory standards.

7

### NOTE

- iPod and iTunes licensing allows individual users to privately reproduce and play non-copyrighted material as well as material that may be legally copied and reproduced. Infringement of copyright is prohibited.



## Handling of Discs

### Supported models

- iPhone5S
- iPhone5c
- iPhone5
- iPhone4S
- iPhone4
- iPhone3GS
- iPhone3G
- iPhone
- iPod Nano (3rd Generation ~ 7th Generation)
- iPod Touch (1st Generation ~ 5th Generation)
- iPod Classic

## Handling of Discs

E00735901196

This explains care that should be taken in the handling of discs.

### Important Points on Handling

- Fingerprints or other marks on the read surface of the disc may result in its content being more difficult to read. When holding the disc, grip both edges, or one edge and the centre hole, in order that the read surface is not touched.
- Do not affix paper or stickers, or otherwise damage the disc.

7-18 For pleasant driving

- Do not forcefully insert a disc if another is already within the device. This can result in damage to discs, or malfunction.

### Cleaning

- Periodically clean the read surface of the disc. When cleaning, do not wipe in a circular motion. Instead, wipe gently outwards from the centre of the disc to the outer edge.
- New discs may have burring around the outer edge or in the hole in the centre. Ensure you check for these. If there are burrs, these may lead to faulty operation, therefore ensure these are removed.

### Important Points on Storage

- When not using discs, ensure these are kept in cases, and stored out of direct sunlight.
- If discs are not going to be used for a long period of time, remove these from the product.

### Disc Playback Environment

In cold environments such as in mid-winter when the interior of the vehicle is cold, turning the heater on and immediately trying to use the product may cause condensation

(water droplets) to form on the disc and internal optical components, and this may prevent the product from operating correctly.

In these conditions, remove the disc, and wait a short time before use.



### Copyright



Actions such as unauthorised reproduction, broadcast, public performance, or rental of discs that comprise other than personal use are prohibited by law.

## Types of Disc That Can Be Played

E00736001194

The following marks are printed on the disc label, package, or jacket.

Type	Size	Maximum playing time	Comments
CD-DA 	12 cm	74 minutes	—
CD-TEXT 	12 cm	74 minutes	—

Type	Size	Maximum playing time	Comments
CD-R/RW  	12 cm	—	•Disc containing MP3, WMA, AAC files

**Discs That May Not Be Played**

- Playback of discs other than those described in “Types of Disc That Can Be Played” is not guaranteed.
- 8 cm discs may not be used.
- Do not insert irregularly-shaped discs (for example, heart-shaped), as these may result in malfunction. Additionally, discs that have transparent portions may not be played.
- Discs that have not been finalized cannot be played.
- Even if recorded using the correct format on a recorder or computer, application software settings and environments; disc peculiarities, damage, or marking; or dirt or condensation on the lens inside the product may render the disc unplayable.

- Depending on the disc, some functions may not be used, or the disc may not be played.
- Do not use discs with cracks or warps.
- If the disc has stickers affixed, remains from removed stickers, or affixed adhesive, then do not use the disc.
- Discs that have decorative labels or stickers may not be used.

**Nonstandard CDs**

This product will play audio CDs, however please be aware of the following points regarding CD standards.

- Ensure that you use discs with  on the label surface.
- Playback of other than standard CDs is not guaranteed. Even if the audio can be played, the audio quality cannot be guaranteed.
- When playing other than standard CDs, the following may occur.
  - There may be noise during playback.
  - There may be jumping in the audio.
  - The disc may not be recognized.
  - The first track may not be played.
  - It may take longer than usual before start of playback of tracks.
  - Playback may start from within the track.

- Some parts may not be played.
- Tracks may freeze during playback.
- Tracks may be displayed erroneously.

**Audio Files (MP3/WMA/AAC)**

E00736101182

This product can play MP3/WMA/AAC format audio files recorded on CD-ROM, CD-R/RW, and USB devices.

There are limitations on the files and media that can be used, therefore read the following prior to recording MP3/WMA/AAC format audio files on discs or USB devices.

Additionally, ensure you read the user manuals for your CD-R/RW drive and the writing software, and ensure these are used correctly. If the MP3/WMA/AAC format audio files includes title information or other data, then this can be displayed.

**CAUTION**

- Actions such as copying audio CDs or files and either distributing these to others for free or for charge, or uploading files via the Internet or other means to servers is an infringement of the law.

## Audio Files (MP3/WMA/AAC)

### CAUTION

- Do not append the file extensions “.mp3”, “.wma”, or “.m4a”, to other than MP3/WMA/AAC format files. Playing discs with these types of files recorded upon them may cause the files to be incorrectly identified for playback, which may lead to loud noise, resulting in speaker damage or accident.

7

### NOTE

- Depending on the condition of the disc recorder or recording software used, correct playback may not be possible. In these cases, refer to the user manual for your product or software.
- Depending on your computer’s operating system, version, software, or settings, files may not have a file extension appended. In these cases, append the file extensions “.mp3”, “.wma”, or “.m4a” when copying the files.

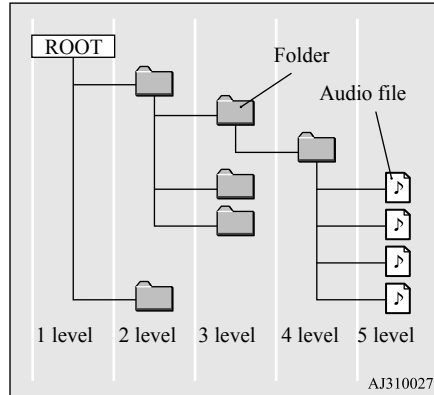

### Folder Structure

E00736301113

Up to 8 folder levels can be recognized. You can create a folder structure as in Genre - Artist - Album - Track (MP3/WMA/AAC format audio files) for management of tracks.

Name	Specification	Explanation	
Format specifications	ISO9660	Level 1	Maximum 8 character file name, and 3 character file extension. (single-byte alphanumeric capital letters, numerals, “_” may be used)
	ISO9660 extension	Joliet	Files names up to a maximum 64 characters can be used.
Multisession	Not supported (only first session supported)		
Maximum number of levels	8 levels (if the root is the 1st level)		
Maximum folder number (including root)	CD	255 folders	
	USB	100 folders	

Name	Specification	Explanation
Maximum file number (total number on media)	CD	509 files
	USB	10,000 files (Up to 100 files can be stored in one folder.)
File name and folder name restrictions	Maximum 64 bytes (for Unicode, 32 characters), files/ folders with file/ folder names longer than this will not be displayed or played.	
USB supported formats	The recommended file system is FAT32. 1 partition only	

**NOTE**

- The order in which folders and audio files are displayed on this product may be different to how they are displayed on a computer.

**What Is MP3?**

E00736401039

MP3 is an abbreviation of “MPEG-1 Audio Layer 3”. MPEG is an abbreviation of “Motion Picture Experts Group”, and this is a

video compression standard used in video CDs, etc.

MP3 is one of the audio compression methods contained in the MPEG audio standard, and reduces the quality of sounds that are beyond the auditory resolution of the human ear and that are hidden by louder sounds, thus creating high-quality data with a lower data size.

Because this can compress CD audio to approximately 1/10 its original data size without perceptible loss, approximately 10 CDs can be written to a single CD-R/RW disc.

**CAUTION**

- MP3 files different to the standards at right may not be played correctly, or file/folder names may not be displayed correctly.

**Standards for MP3 Files That Can Be Played**

Specifications for MP3 files that can be played are as below.

Item	Details
Specification	MPEG-1 AUDIO LAYER3
	MPEG-2 AUDIO LAYER3

Item	Details
Sampling frequency [kHz]	MPEG-1: 32/44.1/48
	MPEG-2: 16/22.05/24
Bit rate [kbps]	MPEG-1: 32 to 320
	MPEG-2: 8 to 180
VBR (variable bit rate)	Support
Channel mode	Stereo/ Joint stereo/ Dual channel/ Monaural
File extension	mp3
Supported tag information	ID3 tag Ver. 1.0, Ver. 1.1, Ver. 2.2, Ver. 2.3, Ver. 2.4 (ISO-8859-1, UTF-16 (Unicode)), Titles, Artist name, Album name
Maximum number of characters that can be indicated on the display	64 characters

**What Is WMA?**

E00736601044

WMA is an abbreviation of Windows Media Audio, and this is an audio compression format from Microsoft. This is a compression

## Audio Files (MP3/WMA/AAC)

format that has a higher compression ratio than MP3.

### NOTE

- Microsoft, Windows Media, and Windows are registered trademarks of Microsoft Corporation (USA) and in other countries.

### CAUTION

- WMA supports digital rights management (DRM). This product cannot play WMA files protected using this system.
- WMA files different to the standards at right may not be played correctly, or file/folder names may not be displayed correctly.
- “Pro”, “Lossless”, and “Voice” are not supported.

### Standards for WMA Files That Can Be Played

Specifications for WMA files that can be played are as below.

Item	Details
Specification	Windows Media Audio Version 7.0/8.0/9.0
Sampling frequency [kHz]	32/44.1/48

Item	Details
Bit rate [kbps]	32 to 192
VBR (variable bit rate)	Support
Channel mode	Stereo/Monaural
File extension	wma
Supported tag information	WMA tags Title name, Artist name, Album name
Maximum number of characters that can be indicated on the display	64 characters

### What Is AAC?

E00736801059

AAC is an abbreviation of Advanced Audio Coding, and this is an audio compression standard used in “MPEG-2” and “MPEG-4”. This features 1.4x the compression of MP3, with comparable audio quality.

### CAUTION

- AAC supports digital rights management (DRM). This product cannot play AAC files protected using this system.

### CAUTION

- AAC files different to the standards at right may not be played correctly, or file/folder names may not be displayed correctly.

### Standards for AAC Files That Can Be Played

Specifications for AAC files that can be played are as below.

Item	Details	
Specification	Advanced Audio Coding MPEG4/AAC-LC MPEG2/AAC-LC	
Sampling frequency [kHz]	MPEG4	8/11.025/12/16/22.05/24/32/44.1/48
	MPEG2	8/11.025/12/16/22.05/24/32/44.1/48
Bit rate [kbps]	MPEG4	16 to 320
	MPEG2	16 to 320
VBR (variable bit rate)	Support	
Channel mode	Stereo/Monaural	
File extension	m4a	

Item	Details
Supported tag information	AAC tags or ID3 tags Title, Artist name, Album name
Maximum number of characters that can be indicated on the display	64 characters

### Important Points on Safety for the Customer

E00737001205

This product features a number of pictorial indications as well as points concerning handling so that you can use the product correctly and in a safe manner, as well as prevent injury or damage to yourself, other users, or property.

**⚠ WARNING**

- The driver should not pay close attention to the display while driving. This may prevent the driver looking where they are going, and cause an accident.

**⚠ WARNING**

- The driver should not perform complicated operations while driving. Performing complicated operations while driving may prevent the driver looking where they are going, and cause an accident. Therefore stop the vehicle in a safe location before performing such operations.
- Do not use during malfunctions, such as when no sound is audible. This may lead to accident, fire, or electric shock.
- Ensure water or other foreign objects do not enter the product. This may lead to smoking, fire, electric shock, or malfunction.
- Do not insert foreign objects into the disc slot. This may lead to fire, electric shock, or malfunction.
- In the event of abnormalities occurring when foreign objects or water enter the product, resulting in smoke or a strange smell, immediately stop using the product, and consult an authorised MITSUBISHI MOTORS dealer. Continuing to use the product may result in accident, fire, or electric shock.
- Do not disassemble or modify the product. This may lead to malfunction, fire, or electric shock.

**⚠ WARNING**

- During thunderstorms, do not touch the antenna or the front panel. This may lead to electrical shock from lightning.

**⚠ CAUTION**

- Do not block ventilation holes or heat sinks on the product. Blocking ventilation holes or heat sinks may prevent heat from escaping from within the product, leading to fire or malfunction.
- Do not turn the volume up to the extent that you cannot hear sounds from outside the vehicle while driving. Driving without being able to hear sounds from outside the vehicle may result in an accident.
- Do not insert your hand or fingers into the disc slot. This may result in injury.

7

### Operation Keys

E00737101219

### Turn the Power ON/ OFF

E00737201148

1. Press the SEL•PWR•VOL key.

## Operation Keys

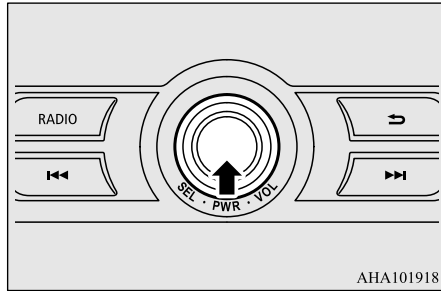

7

- Turn the power on, and resume playback from the previous status.
- Hold down the SEL·PWR·VOL key.  
Turn the power OFF.

### NOTE

- Hold down the steering MODE button (Type 1)/SOURCE button (Type 2) to also turn the audio function ON/OFF.

### Adjust Volume

E00737301123

- Turn the SEL·PWR·VOL key to adjust the volume.

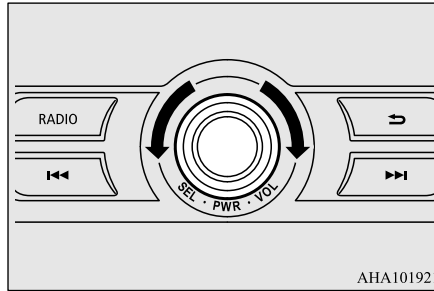

- Turn the SEL·PWR·VOL key clockwise to increase, and counter-clockwise to decrease the volume.

### NOTE

- The maximum value for volume is “49”, and the minimum is “0”.
- The initial setting for volume is “17”.

### Insert/Eject Discs

E00737401049

- Insert the disc into the disc slot with the label surface up.

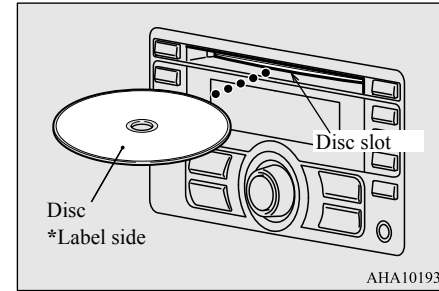

- Push the disc in a certain amount, and the product will pull the disc in, and playback will start.

- Press the ▲ key.  
This will eject the disc from the product, so remove the disc.

### CAUTION

- When replacing discs, first ensure that the vehicle is stopped in an area in which stopping is permitted.
- Do not insert your hand, fingers, or foreign objects into the disc slot. This may lead to injury, smoking, or fire.
- 8 cm CDs are not supported.

## Explanation of Buttons

E00737501431

This explains names and functions of each part.

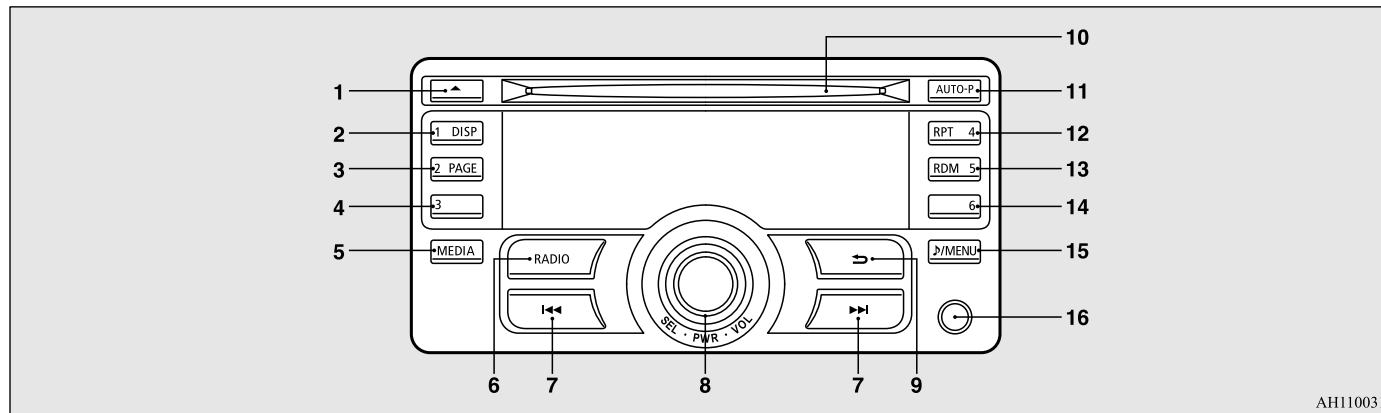

7

AH1100313

- |  |   |  |
|--|---|--|
| <p>1- ▲ key<br/>Use to eject a disc.</p> <p>2- 1DISP key<br/>Switch the content of the display.<br/>For radio, use as preset key 1.</p> <p>3- 2PAGE key<br/>Display the content page forward.<br/>For radio, use as preset key 2.</p> <p>4- 3key<br/>For radio, use as preset key 3.</p> | <p>5- MEDIA key<br/>Each time this is pressed, the audio source switches in the order “CD”, “USB/iPod”, and “AUX”.</p> <p>6- RADIO key<br/>Switch the radio and the band.</p> <p>7- ◀▶ key<br/>For audio, press to select audio track/file and hold down to rewind/fast forward;<br/>for radio, select radio station.</p> | <p>8- SEL•PWR•VOL key<br/>Adjust the volume, and turn the power ON/OFF. Additionally, adjust audio quality and select items.</p> <p>9- ↶ key<br/>Return to the previous operation.</p> <p>10- Disc slot</p> <p>11- AUTO-P key<br/>Auto preset the radio.</p> |
|--|---|--|



## Listen to Radio



- 12- 4RPT key  
For audio, press to turn repeat playback mode on/off; for radio, use as preset key 4.
- 13- 5RDM key  
For audio, press to turn random playback mode on/off; for radio, use as preset key 5.
- 14- 6key  
For radio, use as preset key 6.
- 15-  /MENU key  
Switch to Menu mode.
- 16- Auxiliary Audio connector (mini-jack)  
Connect a commercially-available audio device.

7

### Steering wheel audio remote control switches\*

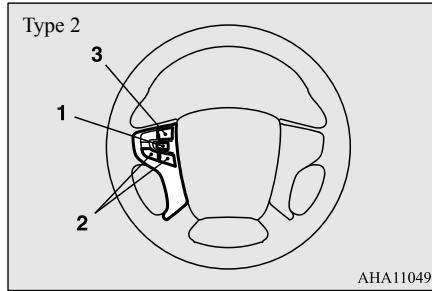
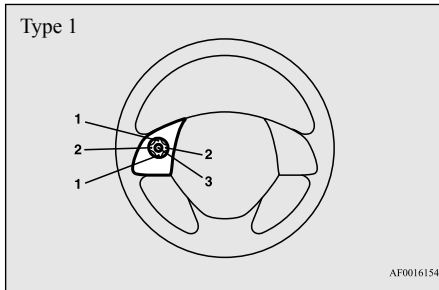
E00737601546



- 1- Volume up/down switch  
Adjust audio functions volume.
- 2-  button,  button  
Select CD and other audio source tracks and radio stations.  
Hold down to fast forward and rewind.
- 3- MODE button (Type 1)/SOURCE button (Type 2)  
Hold down to turn the audio function ON/OFF. Additionally, each time this is pressed, this switches the audio source. The order of switching is as shown below.

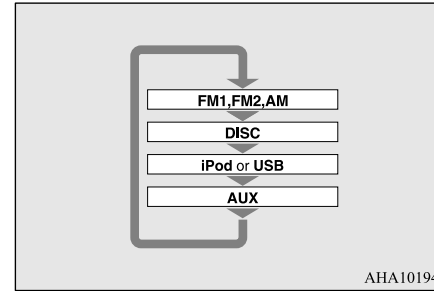

### Listen to Radio

E00737701257

This explains how to listen to AM and FM radio broadcasts.

### To Listen to the Radio

Press the RADIO key to switch the band.

Switch between AM and FM bands.  
The selected band is indicated on the display.

#### NOTE

- Each time the RADIO key is pressed, this switches in the order “FM1”, “FM2”, and “AM”.

## Manual/Seek Station Selection

Press the **1◀◀** key or the **▶▶1** key to the frequency to listen to.

<b>▶▶1</b> key	Increases the frequency being received.
<b>1◀◀</b> key	Reduces the frequency being received.
<b>▶▶1</b> key (hold down)	Release the button to start seek station selection, and when a station is received, scanning stops.
<b>1◀◀</b> key (hold down)	

## Preset Memory

Register the broadcast station in advance, and select this at a later time.

1. Tune in to the frequency to register.
2. Hold down any of the keys from the 1DISP key to the 6 key.

A “Beep” sounds, and the preset key is registered.

### NOTE

- The preset memory can register a maximum of 6 stations for each band.

### NOTE

- If a preset key that already has a station registered is selected, then this is overwritten with the new preset.
- Pressing the preset key will select the previously registered frequency.

## Auto Preset

The top 6 stations with a strong signal can be automatically registered in order with preset keys in the AUTO-P mode.

Hold down the AUTO-P key.

Switch to the AUTO-P mode, and start automatic station selection.

After completion of operations, the product will receive the station registered in the preset key [1].

### CAUTION

- Please be aware that the formerly-registered frequency in the memory will be overwritten.

### NOTE

- Pressing the preset key will select the previously registered frequency.

### NOTE

- Each time the AUTO-P key is pressed, this switches between normal reception and AUTO-P mode.
- In the AUTO-P mode, manual/seek station selection, as well as scan operation is also possible.
- When strong signal is less than 6 stations, the minimum signal is registered in the remaining preset keys.

## Listen to CDs

E00737801203

This explains how to listen to audio CDs (CD-DA/CD-TEXT).

## Play CDs

Insert the disc.

Insert a disc to automatically start playback.  
→ “Insert/Eject Discs” (P.7-24)

If a disc is already within the product, press the MEDIA key to switch to CD as the source.

## Select the Track

Press the **1◀◀** key or **▶▶1** key to select the track.

Listen to MP3s/WMA/AACs

This enables selection of the next or previous track.

### Fast Forward or Rewind

Hold down the ◀◀ key or ▶▶ key.

Fast forward/rewind is possible.

7

### Switch Playback Mode

Repeat playback and random playback are possible.

### Repeat Playback (RPT)

Press the 4RPT key.

Repeat playback of the track currently being played.

#### NOTE

- Pressing again will cancel.
- Ejecting will cancel this.

### Random Playback (RDM)

Press the 5RDM key.

7-28 For pleasant driving

Play the tracks on the disc in a random order.

#### NOTE

- Pressing again will cancel.
- Ejecting will cancel this.

### Search Tracks

This enables search of the track while playing music.

1. Press the SEL•PWR•VOL key.
2. Turn the SEL•PWR•VOL key to select the track.
3. Press the SEL•PWR•VOL key.  
This plays the selected track.

### Listen to MP3s/WMA/AACs

E00737901204

This explains how to listen to audio files on a disc.

### To Listen to MP3s/WMA/AACs

Insert the disc.

Insert a disc to automatically start playback.  
→ “Insert/Eject Discs” (P.7-24)

If a disc is already within the product, press the MEDIA key to switch to CD as the source.

#### NOTE

- Depending on the file structure, it may take some time to read the contents of the disc.

### Select the Track (File)

Press the ◀◀ key or ▶▶ key to select the track.

This enables selection of the next or previous track.

### Fast Forward or Rewind

Hold down the ◀◀ key or ▶▶ key.

Fast forward/rewind is possible.

### Switch Playback Mode

Repeat playback and random playback are possible.

### Repeat Playback (RPT)

Press the 4RPT key.

Repeat playback of the track currently being played.

#### NOTE

- Pressing the 4RPT key two times will cancel.
- Ejecting will cancel this.

### Folder Repeat Playback

Press the 4RPT key during repeat playback of a track.

Repeat playback of the tracks within the folder currently being played.

#### NOTE

- Pressing again will cancel.
- Ejecting will cancel this.
- Even if the file is selected, folder repeat playback will not be cancelled.

### Random Playback (RDM)

Press the 5RDM key.

Play the tracks in the folder in a random order.

#### NOTE

- Pressing the 5RDM key two times will cancel.
- Ejecting will cancel this.

### Folder Random Playback

Press the 5RDM key during playback of the tracks in the folder in a random order.

Play all tracks in folders on the disc in a random order.

#### NOTE

- Pressing again will cancel.

### Search Tracks

Search folders and files, and select a track.



1. Press the SEL•PWR•VOL key.
2. Turn the SEL•PWR•VOL key to select the folder.
3. Press the SEL•PWR•VOL key.

Files within the selected folder are displayed.

4. Turn the SEL•PWR•VOL key to select the file.
5. Press the SEL•PWR•VOL key.

This plays the selected file (track).

#### NOTE

- While the folder is selected, press the  key to cancel track search mode.
- If there is no operation for 10 seconds after selecting the folder, then track search mode will be cancelled.
- While the file is selected, press the  key to return to the previous operation.
- While the file is selected, hold down the  key to cancel track search mode.
- Disc operations such as selecting a track will cancel track search mode.

### Listen to an iPod\*

E00738001518

By connecting commercially-available iPod/iPhone devices to this product, you can play tracks on these through the product.

#### CAUTION

- Do not leave the iPod/iPhone unattended in the vehicle.
- Never hold these devices in your hand to operate while driving, as this is dangerous.

## Listen to an iPod\*

### CAUTION

- No indemnification for data loss resulting when the iPod/iPhone is connected to the product will be possible.
- Depending on how the devices are handled, audio files being damaged or lost, therefore it is recommended that data be backed up.

### NOTE

- Depending on the generation, model, or software version of the iPod/iPhone, playback on this product may not be possible. (→P.7-17) Additionally, playback as explained in this document may not be possible.
- Usage of iPod/iPhone hardware with the latest software version is recommended.
- Regarding how to connect the iPod/iPhone, refer to “How to connect an iPod” on page 7-65.
- When connecting the iPod/iPhone, use a commercially-available iPod connection cable.
- Set up the device in order that no unsafe actions, such as plugging in the connection cable are taken while driving.
- When inserting and removing the iPod/iPhone, for safety’s sake first stop the vehicle.
- Depending on the status of the iPod/iPhone, it may take some time until the device is recognized, or playback starts.

### NOTE

- Depending on the iPod/iPhone, the button functions on the product may not operate while the iPod/iPhone is connected.
- iPod/iPhone specifications and settings may mean that connection is not possible, or result in differences in operation or display.
- Depending on audio data in the iPod/iPhone, track information may not be displayed correctly.
- Depending on the status of the vehicle and device, the iPod/iPhone may not be played after starting the engine.
- Data containing copyright information may not be played back.
- It is recommended that the iPod/iPhone equaliser settings be set to flat.
- Operate the iPod/iPhone while connected to this product.
- If an iPod/iPhone does not operate correctly, then remove the iPod/iPhone from the product, reset, then reconnect.

### Play iPod

Press the MEDIA key to set the USB (iPod) as the source.

The selected source is indicated on the display.

### Select the Track (File)

Press the ◀◀ key or ▶▶ key to select the track.

This enables selection of the next or previous track.

### Fast Forward or Rewind

Hold down the ◀◀ key or ▶▶ key.

Fast forward/rewind is possible.

### Switch Playback Mode

Repeat playback and shuffle playback are possible.

### Repeat Playback (RPT)

Press the 4RPT key.

Repeat playback of the track currently being played.

### NOTE

- Pressing again will cancel.

## Shuffle Playback (RDM)

Press the 5RDM key.

Play tracks in the category currently being played in a random order.

### NOTE

- Pressing the 5RDM key two times will cancel.

## Album Shuffle Playback

Press the 5RDM key during playback of the album in a random order.

Play the album in a random order (tracks in any order on the album).

### NOTE

- Pressing again will cancel.



## Search Tracks

Search categories or track names, and select a track.

1. Press the SEL•PWR•VOL key.

2. Turn the SEL•PWR•VOL key to select the category.
3. Press the SEL•PWR•VOL key. Categories or tracks within the selected category are displayed.
4. Turn the SEL•PWR•VOL key to select the category or track.
5. Press the SEL•PWR•VOL key. Repeat steps 1 to 4, and search for tracks. Select the track, and press the SEL•PWR•VOL key to play.

### NOTE

- While the category (1st level) is selected, press the  key to cancel track search mode.
- If there is no operation for 10 seconds after selecting the category, then track search mode will be cancelled.
- While the track is selected, press the  key to return to the previous operation.
- While the track is selected, hold down the  key to cancel track search mode.
- iPod operations such as selecting a track will cancel track search mode.

## Listen to Audio Files on a USB Device\*

### Listen to Audio Files on a USB Device\*

E00736501522

By connecting commercially-available USB devices such as USB memory to this product, you can play audio files on these through the product.

### CAUTION

- Do not leave the USB device unattended in the vehicle.
- Never hold these devices in your hand to operate while driving, as this is dangerous.
- Do not use hard discs, card readers, or memory readers, as damage may occur to these or to the data contained therein. If these are erroneously connected, then turn the ignition switch to the “LOCK” position or put the operation mode in OFF, then remove.
- Because of the risk of data loss, it is recommended that files be backed up.
- No guarantee is made as regards damage to the USB device, nor regarding loss or damage to data contained therein.
- Depending on how the devices are handled, audio files being damaged or lost, therefore it is recommended that data be backed up.

7

## Listen to Audio Files on a USB Device\*

7

### NOTE

- Digital audio players that support the mass storage class specifications can be connected.
- Regarding how to connect USB devices, refer to “How to connect a USB memory device” on page 7-64.
- When connecting a USB device, use a connection cable. Failure to use a connection cable when connecting may place undue load on, or damage the USB connector.
- Set up the device in order that no unsafe actions, such as plugging in the connection cable are taken while driving.
- When inserting and removing the USB device, for safety’s sake first stop the vehicle.
- Do not insert other than audio devices into the USB port. Damage to the device or equipment may result.
- Depending on the status of the USB device, it may take some time until the device is recognized, or playback starts.
- Depending on the USB device, the button functions on the product may not operate while the USB device is connected.
- USB device specifications and settings may mean that connection is not possible, or result in differences in operation or display.
- Depending on audio data in the USB device, track information may not be displayed correctly.

### NOTE

- Depending on the status of the vehicle and device, the iPod/iPhone may not be played after starting the engine.
- Data containing copyright information may not be played back.
- This product can play MP3, WMA, and AAC format audio files.
- Depending on the type of USB device, usage may not be possible, or functions that can be used may be restricted.
- The recommended file system for USB memory is FAT32.
- The maximum supported capacity for USB memory is 32GB.
- Operate the USB device containing recorded audio files while connected to this product.

### Playback of Audio Files on a USB Device

Press the MEDIA key to set

USB as the source. The selected source is indicated on the display.

### Select the Track (File)

Press the **1◀◀** key or **▶▶1** key to select the track.

This enables selection of the next or previous track.

### Fast Forward or Rewind

Hold down the **1◀◀** key or **▶▶1** key.

Fast forward/rewind is possible.

### Switch Playback Mode

Repeat playback and random playback are possible.

### Repeat Playback (RPT)

Press the 4RPT key.

Repeat playback of the track currently being played.

### NOTE

- Pressing the 4RPT key two times will cancel.

### Folder Repeat Playback

Press the 4RPT key during repeat playback of a track.

Repeat playback of the tracks within the folder currently being played.

**NOTE**

- Pressing again will cancel.
- Even if the file is selected, folder repeat playback will not be cancelled.

### Folder Random Playback (RDM)

Press the 5RDM key.

Play tracks in the folder currently being played in a random order.

**NOTE**

- Pressing the 5RDM key two times will cancel.

### All Folder Random Playback

Press the 5RDM key during playback of the tracks in the folder in a random order.

Play the tracks in all folders in a random order.

**NOTE**

- Pressing again will cancel.

**NOTE**

- Even if the file is selected, all folder random playback will not be cancelled.

### Search Tracks

Search folders and files, and select a track.

1. Press the SEL•PWR•VOL key.
2. Turn the SEL•PWR•VOL key to select the folder.
3. Press the SEL•PWR•VOL key.  
Files within the selected folder are displayed.
4. Turn the SEL•PWR•VOL key to select the file.
5. Press the SEL•PWR•VOL key.  
This plays the selected file (track).

**NOTE**

- While the folder is selected, press the **↵** key to cancel track search mode.
- If there is no operation for 10 seconds after selecting the folder, then track search mode will be cancelled.
- While the file is selected, press the **↵** key to return to the previous operation.
- While the file is selected, hold down the **↵** key to cancel track search mode.
- Operations such as selecting a track will cancel track search mode.

## Use AUX

E00736901249

By connecting external input cables and AUX devices to this product, you can play tracks on these devices through the product.

Press the MEDIA key to switch to the AUX mode.

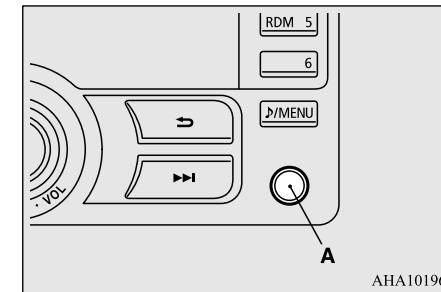

**7**

A- Auxiliary Audio connector (mini-jack)

**CAUTION**

- Connect an audio device with external sound input mode canceled, or with the sound turned down.
- Even if not inserted, the product will switch to AUX, therefore take care with volume levels when not inserted.



## Display Indicator

7

### NOTE

- Depending on the audio device to be connected, noise may be emitted.
- For power, use the battery power source included in the audio device to be connected. Using the connected audio device while charging through the cigarette lighter socket in the vehicle may lead to noise being emitted through the speakers.
- If no audio devices are connected, then do not select the external sound input mode. If external sound input mode is selected while no audio devices are connected, then sound may be emitted through the speakers.

## Display Indicator

E00738101085

This explains content of the display indicator.



## Change the Display Mode

E00738501249

You can change the content of the display indicator.  
Press the 1DISP key to switch the display content.

Each time the 1DISP key is pressed, the display content changes.

### CAUTION

- The operation of changing display contents may impede safe driving, therefore check safety before operation.

### NOTE

- Up to 10 characters may be displayed at one time. To display 11 or more characters, press the 2PAGE key, and subsequent characters will be displayed.

## During CD-DA playback

This switches in the order “Track No. + Playtime”, “Disc text” and “Track text”.

### NOTE

- If there is no artist text information to display, then “Track No. + Playtime” is displayed.
- If there is no album text information to display, then “DISC TEXT” is displayed.
- If there is no song text information to display, then “TRACK TEXT” is displayed.

## During MP3/WMA/AAC Playback

This switches in the order “Track No. + Playtime”, “Folder no/File no”, “Folder text”, “File text”, “Artist text”, “Album text” and “Song text”.

### NOTE

- If there is no artist text information to display, then “ARTIST” is displayed.
- If there is no album text information to display, then “ALBUM” is displayed.
- If there is no song text information to display, then “SONG” is displayed.

**During iPod Playback**

E00738901054

During other than Podcast playback, this switches in the order “Track No. + playtime”, “Artist text”, “Album text” and “Song text”. During Podcast playback, this switches in the order “Track No. + playtime”, “Podcast name”, “Episode name” and “Release date”.

**NOTE**

- If there is no artist text information to display, then “ARTIST” is displayed.
- If there is no album text information to display, then “ALBUM” is displayed.
- If there is no song text information to display, then “SONG” is displayed.

**Audio Quality and Volume Balance Adjustment**

E00738201376

Change audio quality settings.

**Adjust Audio Quality and Volume Balance**

1. Press the **▶/MENU** key.
2. Turn the **SEL•PWR•VOL** key to select adjustment items and press the **SEL•PWR•VOL** key.

Turning the **SEL•PWR•VOL** key counter-clockwise or clockwise, the adjustment items switch as shown below.

**BASS**↔**TREBLE**↔**FADER**↔**BALANCE**

3. Turn the **SEL•PWR•VOL** key to adjust the adjustment items selected.

Adjustment items	Turn counter-clockwise	Turn clockwise
BASS	-5~0 (Decrease low frequency volume)	0~+5 (Increase low frequency volume)
TREBLE	-5~0 (Decrease high frequency volume)	0~+5 (Increase high frequency volume)
FADER	R11~0 (Emphasise REAR)	0~F11 (Emphasise FRONT)
BALANCE	L11~0 (Emphasise LEFT)	0~R11 (Emphasise RIGHT)

**Time Setting**

E00770700107

This explains how to set time.

1. Hold down the **▶/MENU** key.
2. Turn the **SEL•PWR•VOL** key to select “CLOCK MODE” or “CLOCK ADJUST MODE”.
3. Press the **SEL•PWR•VOL** key to complete.  
The selected item is indicated on the display.

**CLOCK MODE**

This enables selection of the 12-hour clock or the 24-hour clock.

1. Turn the **SEL•PWR•VOL** key to select the 12-hour clock or the 24-hour clock.
2. Press the **SEL•PWR•VOL** key to complete and the clock display is changed.

**CLOCK ADJUST MODE**

Set the time manually.

1. Turn the **SEL•PWR•VOL** key to adjust the hour.
2. Press the **SEL•PWR•VOL** key to set the hour then shift to adjust the minutes.
3. Turn the **SEL•PWR•VOL** key to adjust the minutes.
4. Press the **▶/MENU** key.  
This completes the adjustment.

## Troubleshooting

### Troubleshooting

E00738401310

Please check these items if a message appears on the display, or if you think something is not working properly.

### If This Message Appears...

A message is displayed on this product according to the situation.

7

Mode	Message	Cause	Response
CD	DISC_ERROR	The disc is damaged and/or dirty.	Clean the read surface of the disc.
	EJECT_E	The disc cannot be ejected.	Wait a while before ejecting again. If the problem persists, consult an authorised MITSUBISHI MOTORS dealer.
	UNSUPPORT	Unsupported audio files have been played.	Confirm audio files that can be played. → “Audio files (MP3/WMA/AAC)” (P.7-19)
	PROTECT	Audio files protected by DRM (Digital Rights Management) have been played.	Use audio files without DRM (Digital Rights Management).
	COM_ERROR	Reading the contents of the CD has malfunctioned for some reason.	Turn the power OFF and wait a while. If the problem persists, consult an authorised MITSUBISHI MOTORS dealer.

Mode	Message	Cause	Response
USB	NO_FILE	There are no audio files that can be played.	Confirm audio files that can be played. → “Audio files (MP3/WMA/AAC)” (P.7-19)
	DEVICE_ERR	An unsupported USB device has been connected.	Confirm the USB device.
	BUS_POWER	There is high electrical current.	Confirm the USB device.
	UNSUPPORT	Unsupported audio files have been played.	Select audio files that can be played. → “Audio files (MP3/WMA/AAC)” (P.7-19)
	PROTECT	Audio files protected by DRM (Digital Rights Management) have been played.	Select audio files that can be played. → “Audio files (MP3/WMA/AAC)” (P.7-19)
	COM_ERROR	Reading the contents of the USB has malfunctioned for some reason.	Turn the power OFF and wait a while. If the problem persists, consult an authorised MITSUBISHI MOTORS dealer.
iPod	NO_SONG	An iPod/iPhone not containing any tracks has been connected.	Connect an iPod/iPhone containing tracks.
	DEVICE_ERR	Audio data in the iPod/iPhone cannot be read.	Confirm the iPod/iPhone that can be used. → “Trademarks” (P.7-17)
	BUS_POWER	There is high electrical current.	Confirm the USB device.
	AUT-ERROR	iPod/iPhone is not recognized correctly.	Confirm the iPod/iPhone.
	COM_ERROR	Reading the audio data in the iPod/iPhone has malfunctioned for some reason.	Turn the power OFF and wait a while. If the problem persists, consult an authorised MITSUBISHI MOTORS dealer.
	VER_ERROR	This iPod/iPhone software version is not supported.	Please change to a supported software version.

## AM/FM radio/CD player\*

### AM/FM radio/CD player\*

E00708503550

The audio system can only be used when the ignition switch or the operation mode is in ON or ACC.

#### NOTE

- For vehicles equipped with the Keyless operation system, if the operation mode is left in ACC, the accessory power will automatically turn off after a certain period of time and you will no longer be able to use the audio system. The accessory power comes on again if the engine switch is operated with it in the “ACC” position. Refer to “ACC power auto-cutout function” on page 6-15.
- If a cellular phone is used inside the vehicle, it may create noise from the audio equipment. This does not mean that anything is wrong with your audio equipment. In such a case, use the cellular phone at a place as far away as possible from the audio equipment.
- If foreign objects or water get into the audio equipment, or if smoke or a strange odour comes from it, immediately turn off the audio system. We recommend you to have it checked. Never try to repair it by yourself. Avoid continuous usage without inspection by a qualified person.

7

### Important Points on Usage

E00735501033

#### iPod/iPhone Playback Function\*

- This product supports audio playback from iPod/iPhone devices, however differing versions mean that playback cannot be guaranteed.
- Please be aware that depending on the iPod/iPhone model or version, operation may differ.

#### How to Clean

E00735701035

- If the product becomes dirty, wipe with a soft cloth.
- If very dirty, use a soft cloth dipped in neutral detergent diluted in water, and then wrung out. Do not use benzene, thinners, or other chemical wipes. This may harm the surface.

#### Trademarks

E00735801254

- Product names and other proper names are the trademarks or registered trademarks of their respective owners.

- Furthermore, even if there is no specific denotation of trademarks or registered trademarks, these are to be observed in their entirety.













“Made for iPod”, “Made for iPhone” mean that an electronic accessory has been designed to connect specifically to iPod or iPhone, respectively, and has been certified by the developer to meet Apple performance standards.

iPhone, iPod, iPod classic, iPod nano, and iPod touch are trademarks of Apple Inc., registered in the U.S. and other countries. Apple is not responsible for the operation of this device or its compliance with safety and regulatory standards.

#### NOTE

- iPod and iTunes licensing allows individual users to privately reproduce and play back non-copyrighted material as well as material that may be legally copied and reproduced. Infringement of copyright is prohibited.

iPod		iPod classic		
				
<b>iPod</b> 5th generation (video) 60GB 80GB	<b>iPod</b> 5th generation (video) 30GB	<b>iPod classic</b> 160GB (2009)	<b>iPod classic</b> 160GB (2007)	<b>iPod classic</b> 80GB
iPod nano				
				
<b>iPod nano</b> 6th generation 8GB 16GB	<b>iPod nano</b> 5th generation (video camera) 8GB 16GB	<b>iPod nano</b> 4th generation (video) 8GB 16GB		
				
<b>iPod nano</b> 3rd generation (video) 4GB 8GB	<b>iPod nano</b> 2nd generation (aluminum) 2GB 4GB 8GB	<b>iPod nano</b> 1st generation 1GB 2GB 4GB		

AA5013326

AM/FM radio/CD player\*

7

iPod touch



**iPod touch**

4th generation  
8GB 32GB 64GB

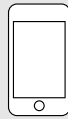

**iPod touch**

3rd generation  
32GB 64GB



**iPod touch**

2nd generation  
8GB 32GB 64GB



**iPod touch**

1st generation  
8GB 32GB 64GB

iPhone



**iPhone 4S**

16GB 32GB 64GB



**iPhone 4**

16GB 32GB



**iPhone 3GS**

8GB 16GB 32GB



**iPhone 3G**

8GB 16GB

AJ5100128

## Handling of Discs

E00735901200

This explains care that should be taken in the handling of discs.

### Important Points on Handling

- Fingerprints or other marks on the read surface of the disc may result in its content being more difficult to read. When holding the disc, grip both edges, or one edge and the centre hole, in order that the read surface is not touched.
- Do not affix paper or stickers, or otherwise damage the disc.
- Do not forcefully insert a disc if another is already within the device. This can result in damage to discs, or malfunction.

### Cleaning

- Periodically clean the read surface of the disc. When cleaning, do not wipe in a circular motion. Instead, wipe gently outwards from the centre of the disc to the outer edge.
- New discs may have burring around the outer edge or in the hole in the centre. Ensure you check for these. If there are burrs, these may lead to faulty operation, therefore ensure these are removed.

### Important Points on Storage

- When not using discs, ensure these are kept in cases, and stored out of direct sunlight.
- If discs are not going to be used for a long period of time, remove these from the product.

### Disc Playback Environment

In cold environments such as in mid-winter when the interior of the vehicle is cold, turning the heater on and immediately trying to use the product may cause condensation (water droplets) to form on the disc and internal optical components, and this may prevent the product from operating correctly. In these conditions, remove the disc, and wait a short time before use.





### Copyright

Actions such as unauthorised reproduction, broadcast, public performance, or rental of discs that comprise other than personal use are prohibited by law.

## Types of Disc That Can Be Played Back

E00736001110

The following marks are printed on the disc label, package, or jacket.

Type	Size	Maximum playback time	Comments
CD-DA 	12 cm	74 minutes	—
CD-TEXT 	12 cm	74 minutes	—
CD-R/RW  	12 cm	—	•Disc containing MP3 files

7

### Discs That May Not Be Played Back

- Playback of discs other than those described in “Types of Disc That Can Be Played Back” is not guaranteed.



### Audio Files (MP3/WMA/AAC)

- 8 cm discs may not be used.
- Do not insert irregularly-shaped discs (for example, heart-shaped), as these may result in malfunction. Additionally, discs that have transparent portions may not be played back.
- Discs that have not been finalized cannot be played back.
- Even if recorded using the correct format on a recorder or computer, application software settings and environments; disc peculiarities, damage, or marking; or dirt or condensation on the lens inside the product may render the disc unplayable.
- Depending on the disc, some functions may not be used, or the disc may not play back.
- Do not use discs with cracks or warps.
- If the disc has stickers affixed, remains from removed stickers, or affixed adhesive, then do not use the disc.
- Discs that have decorative labels or stickers may not be used.

#### Nonstandard CDs

This product will play back audio CDs, however please be aware of the following points regarding CD standards.

- Ensure that you use discs with  on the label surface.

- Playback of other than standard CDs is not guaranteed. Even if the audio can be played back, the audio quality cannot be guaranteed.
- When playing back other than standard CDs, the following may occur.
  - There may be noise during playback.
  - There may be jumping in the audio.
  - The disc may not be recognized.
  - The first track may not be played back.
  - It may take longer than usual until start of playback of tracks.
  - Playback may start from within the track.
  - Some parts may not be played back.
  - Tracks may freeze during playback.
  - Tracks may be displayed erroneously.

### Audio Files (MP3/WMA/AAC)

E00736101195

This product can play back MP3/WMA/AAC format audio files recorded on CD-ROM, CD-R/RW, and USB devices.

There are limitations on the files and media that can be used, therefore read the following prior to recording MP3/WMA/AAC format audio files on discs or USB devices.

Additionally, ensure you read the user manuals for your CD-R/RW drive and the writing software, and ensure these are used correctly. If the MP3/WMA/AAC format audio files includes title information or other data, then this can be displayed.

**CAUTION**

- CD-ROM and CD-R/RW media can only play back MP3 format audio files.
- Actions such as copying audio CDs or files and either distributing these to others for free or for charge, or uploading files via the Internet or other means to servers is an infringement of the law.
- Do not append the file extensions “.mp3”, “.wma”, or “.m4a”, to other than MP3/WMA/AAC format files. Playing back discs with these types of files recorded upon them may cause the files to be incorrectly identified for playback, which may lead to loud noise, resulting in speaker damage or accident.

**NOTE**

- Depending on the condition of the disc recorder or recording software used, correct playback may not be possible. In these cases, refer to the user manual for your product or software.

**NOTE**

- Depending on your computer's operating system, version, software, or settings, files may not have a file extension appended. In these cases, append the file extensions ".mp3", ".wma", or ".m4a" when copying the files.
- Files larger than 2GB in size cannot be played back.

**Data Formats That Can Be Played Back**

E00736200030

Data formats that can be played on discs (CD-ROM, CD-R/RW) and USB devices differ.

Data format	DISC	USB device
MP3	○	○
WMA	X	○
AAC	X	○

**Folder Structure**

E00736301067

Up to 8 folder levels can be recognized. You can create a folder structure as in Genre - Artist - Album - Track (MP3/WMA/AAC format audio files) for management of tracks.

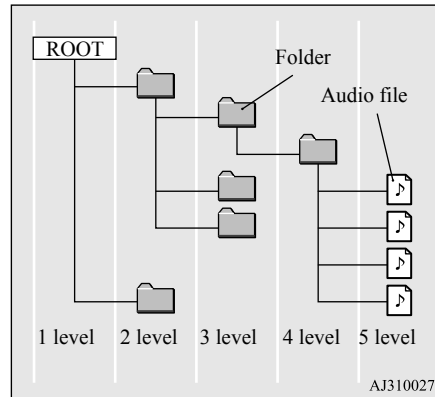

Name	Specification	Explanation
Format specifications	ISO9660 Level 1	Maximum 8 character file name, and 3 character file extension. (single-byte alphanumeric capital letters, numerals, “_” may be used)
	ISO9660 extension Joliet	Files names up to a maximum 64 characters can be used.
Multisession	Not supported (only first session supported)	
Maximum number of levels	8 levels (if the root is the 1st level)	
Maximum folder number	700 folders (including root)	
Maximum file number*1	65,535 files (total number on media. Other than MP3, WMA, and AAC files not included)	

## Audio Files (MP3/WMA/AAC)

**7**

Name	Specification	Explanation
File name and folder name restrictions	Maximum 64 bytes (for Unicode, 32 characters), files/ folders with file/ folder names longer than this will not be displayed or played back.	
USB supported formats	The recommended file system is FAT32. 1 partition only	

\*1. Do not include other than MP3/WMA/AAC files. However, if storing many tracks within the same folder, these may not be recognized even if less than the maximum number of tracks. In these cases, divide the tracks up into multiple folders.

 NOTE
<ul style="list-style-type: none"> <li>The order in which folders and audio files are displayed on this product may be different to how they are displayed on a computer.</li> </ul>

### What Is MP3?

E00736400029

MP3 is an abbreviation of “MPEG-1 Audio Layer 3”. MPEG is an abbreviation of

“Motion Picture Experts Group”, and this is a video compression standard used in video CDs, etc.

MP3 is one of the audio compression methods contained in the MPEG audio standard, and reduces the quality of sounds that are beyond the auditory resolution of the human ear and that are hidden by louder sounds, thus creating high-quality data with a lower data size.

Because this can compress CD audio to approximately 1/10 its original data size without perceptible loss, approximately 10 CDs can be written to a single CD-R/RW disc.

 CAUTION
<ul style="list-style-type: none"> <li>MP3 files different to the standards at right may not play back correctly, or file/folder names may not be displayed correctly.</li> </ul>

### Standards for MP3 Files That Can Be Played Back

Specifications for MP3 files that can be played are as below.

Item	Details
Specification	MPEG-1 AUDIO LAYER3
	MPEG-2 AUDIO LAYER3

Item	Details
Sampling frequency [kHz]	MPEG-1: 32/44.1/48
	MPEG-2: 16/22.05/24
Bit rate [kbps]	MPEG-1: 32 to 320
	MPEG-2: 8 to 160
VBR (variable bit rate)	Support
Channel mode	Stereo/ Joint stereo/ Dual channel/ Monaural
File extension	mp3
Supported tag information	ID3 tag Ver. 1.0, Ver. 1.1, Ver. 2.2, Ver. 2.3, Ver. 2.4 (ISO-8859-1, UTF-16 (Unicode)), Titles, Artist name, Album name
Maximum number of characters that can be indicated on the display	64 characters

### What Is WMA?

E00736601031

WMA is an abbreviation of Windows Media Audio, and this is an audio compression format from Microsoft. This is a compression

format that has a higher compression ratio than MP3.

**NOTE**

- Microsoft, Windows Media, and Windows are registered trademarks of Microsoft Corporation (USA) and in other countries.

**CAUTION**

- WMA supports digital rights management (DRM). This product cannot play back WMA files protected using this system.
- WMA files different to the standards at right may not play back correctly, or file/folder names may not be displayed correctly.
- “Pro”, “Lossless”, and “Voice” are not supported.

### Standards for WMA Files That Can Be Played Back

Specifications for WMA files that can be played are as below.

Item	Details
Specification	Windows Media Audio Version7.0/8.0/9.0
Sampling frequency [kHz]	32/44.1/48

Item	Details
Bit rate [kbps]	48 to 320
VBR (variable bit rate)	Support
Channel mode	Stereo/Monaural
File extension	wma
Supported tag information	WMA tags Title name, Artist name, Album name
Maximum number of characters that can be indicated on the display	64 characters

### What Is AAC?

E00736801046

AAC is an abbreviation of Advanced Audio Coding, and this is an audio compression standard used in “MPEG-2” and “MPEG-4”. This features 1.4x the compression of MP3, with comparable audio quality.

**CAUTION**

- AAC supports digital rights management (DRM). This product cannot play back AAC files protected using this system.

**CAUTION**

- AAC files different to the standards at right may not play back correctly, or file/folder names may not be displayed correctly.

### Standards for AAC Files That Can Be Played Back

Specifications for AAC files that can be played are as below.

7

Item	Details	
Specification	Advanced Audio Coding MPEG4/AAC-LC MPEG2/AAC-LC	
Sampling frequency [kHz]	MPEG4	8/11.025/12/16/22.05/24/32/44.1/48
	MPEG2	8/11.025/12/16/22.05/24/32/44.1/48
Bit rate [kbps]	MPEG4	8 to 320
	MPEG2	8 to 320
VBR (variable bit rate)	Support	
Channel mode	Stereo/Monaural	
File extension	m4a	

## Important Points on Safety for the Customer

Item	Details
Supported tag information	AAC tags or ID3 tags Title, Artist name, Album name
Maximum number of characters that can be indicated on the display	64 characters

### 7

## Important Points on Safety for the Customer

E00737001218

This product features a number of pictorial indications as well as points concerning handling so that you can use the product correctly and in a safe manner, as well as prevent injury or damage to yourself, other users, or property.

### WARNING

- The driver should not pay close attention to the display while driving. This may prevent the driver looking where they are going, and cause an accident.

### WARNING

- The driver should not perform complicated operations while driving. Performing complicated operations while driving may prevent the driver looking where they are going, and cause an accident. Therefore stop the vehicle in a safe location before performing such operations.
- Do not use during malfunctions, such as when no sound is audible. This may lead to accident, fire, or electric shock.
- Ensure water or other foreign objects do not enter the product. This may lead to smoking, fire, electric shock, or malfunction.
- Do not insert foreign objects into the disc slot. This may lead to fire, electric shock, or malfunction.
- In the event of abnormalities occurring when foreign objects or water enter the product, resulting in smoke or a strange smell, immediately stop using the product, and consult an authorised MITSUBISHI MOTORS dealer. Continuing to use the product may result in accident, fire, or electric shock.
- Do not disassemble or modify the product. This may lead to malfunction, fire, or electric shock.

### WARNING

- During thunderstorms, do not touch the antenna or the front panel. This may lead to electrical shock from lightning.

### CAUTION

- Do not block ventilation holes or heat sinks on the product. Blocking ventilation holes or heat sinks may prevent heat from escaping from within the product, leading to fire or malfunction.
- Do not turn the volume up to the extent that you cannot hear sounds from outside the vehicle while driving. Driving without being able to hear sounds from outside the vehicle may result in an accident.
- Do not insert your hand or fingers into the disc slot. This may result in injury.

## Operation Keys

E00737101222

### Turn the Power ON/ OFF

E00737201151

1. Press the PWR/VOL key.

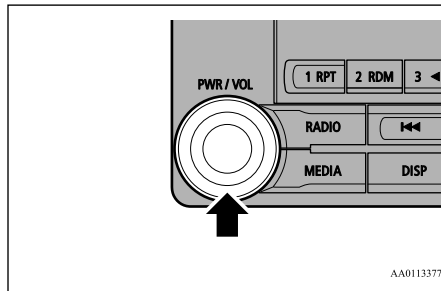

- Turn the power on, and resume playback from the previous status.
2. Press the PWR/VOL key.  
Turn the power OFF.

**NOTE**

- Hold down the steering MODE button (Type 1)/SOURCE button (Type 2) to also turn the audio function ON/OFF.

### Adjust Volume

E00737300025

1. Turn the PWR/VOL key to adjust the volume.

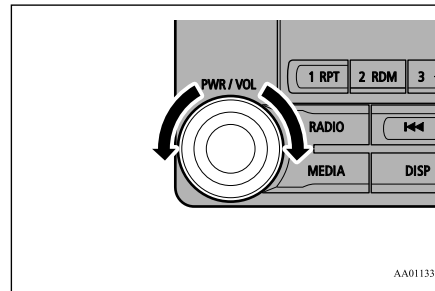

Turn the PWR/VOL key clockwise to increase, and counter-clockwise to decrease the volume.

**NOTE**

- The maximum value for volume is 45, and the minimum is 0.
- The initial setting for volume is "17".

### Insert/Eject Discs

E00737401036

1. Insert the disc into the disc slot with the label surface up.

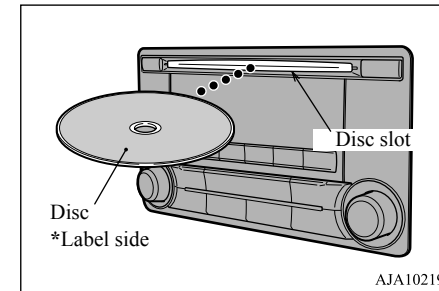

Push the disc in a certain amount, and the product will pull the disc in, and playback will start.

2. Press the ▲ key.  
This will eject the disc from the product, so remove the disc.

**CAUTION**

- When replacing discs, first ensure that the vehicle is stopped in an area in which stopping is permitted.
- Do not insert your hand, fingers, or foreign objects into the disc slot. This may lead to injury, smoking, or fire.
- 8 cm CDs are not supported.

## Operation Keys

### Explanation of Buttons

E00737501141

This explains names and functions of each part.

7

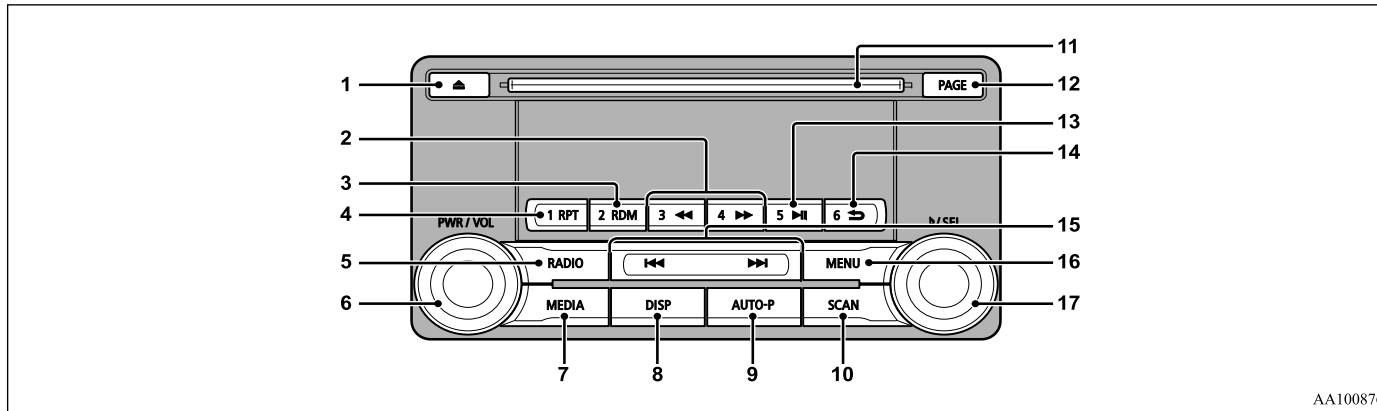

- 1- ▲ key  
Use to eject a disc.
- 2- 3◀◀ key/4▶▶ key  
For audio, rewind/fast forward.  
For radio, use as preset keys 3 and 4.
- 3- 2RDM key  
For audio, play random playback; for radio, use as preset key 2.
- 4- 1RPT key  
For audio, play repeat playback; for radio, use as preset key 1.

- 5- RADIO key  
Switch the radio and the band.
- 6- PWR/VOL key  
Adjust the volume, and turn the power ON/OFF.
- 7- MEDIA key  
Switch between CD and other sources.
- 8- DISP key  
Switch the content of the display.
- 9- AUTO-P key  
Auto preset the radio.

- 10- SCAN key  
For audio, play scan playback; for radio, scan for stations.
- 11- Disc slot
- 12- PAGE key  
Display indicator page advance.
- 13- 5 ►|| key  
Use as preset key 5 for radio.
- 14- 6 ⇄ key  
Return during audio track search.  
For radio, use as preset key 6.

7-48 For pleasant driving

- 15- **1◀◀ key/▶▶1 key**  
For audio, select audio track/file; for radio, perform automatic station selection.
- 16- **MENU key**  
Switch to Menu mode.
- 17- **▶/SEL key**  
Adjust audio quality and select items.  
For radio, manually select stations.

**Steering wheel audio remote control switches\***

E00737601559

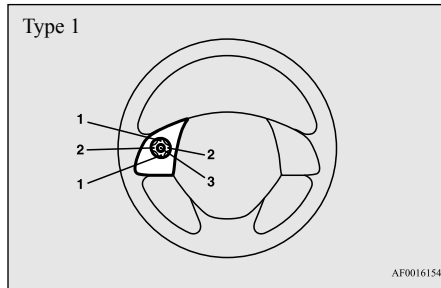

AF0016154

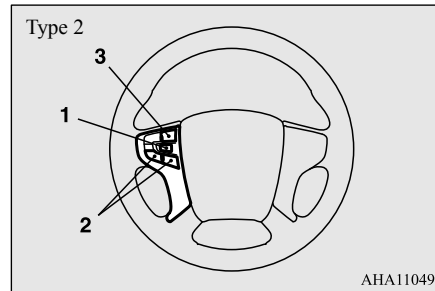

AHA110493

- 1- **Volume up/down switch**  
Adjust audio functions and the mobile phone function volume.
- 2- **< button, > button**  
Select CD and other audio source tracks and radio stations.
- 3- **MODE button (Type 1)/SOURCE button (Type 2)**  
Hold down to turn the audio function ON/OFF. Additionally, each time this is pressed, this switches the audio source. The order of switching is as shown below.  
If devices are not connected, then these are to be skipped, and the next source selected.

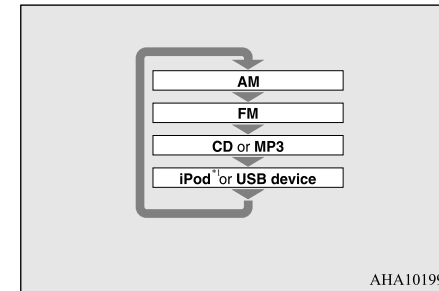

AHA101992

\*: An iPod cable (available separately) is required.

**7**

**Listen to Radio**

E00737701202

This explains how to listen to AM and FM radio broadcasts.

**To Listen to the Radio**

Press the RADIO key to switch the band.

Switch between AM and FM bands.  
The selected band is indicated on the display.

**NOTE**





- This switches between AM and FM.



## Listen to Radio

### Manual/Seek Station Selection

Turn the /SEL key to the frequency to listen to.

 /SEL key (counter-clockwise)	Reduces the frequency being received.
 /SEL key (clockwise)	Increases the frequency being received.
 key (hold down)	Release the button to start seek station selection, and when a station is received, scanning stops.
 key (hold down)	

### Scan Station Selection

Collective search for stations that can be received.

Press the SCAN key.

When a station is received, this is played for 5 seconds, then the product searches for the next station.

### NOTE

- Press this button again while receiving the station to return to normal reception.

### Preset Memory

Register the broadcast station in advance, and select this at a later time.

1. Tune in to the frequency to register.
2. Hold down any of the keys from the 1RPT key to the 6  key.

A “Beep” sounds, and the preset key is registered.

### NOTE

- The preset memory can register a maximum of 6 stations for each band.
- If a preset key that already has a station registered is selected, then this is overwritten with the new preset.
- Pressing the preset key will select the previously registered frequency.

### Auto Preset

The top 6 stations with a strong signal can be automatically registered in order with preset keys in the AUTO-P mode.

Hold down the AUTO-P key.

Switch to the AUTO-P mode, and start automatic station selection.

After completion of operations, the product will receive the station registered in the preset key [1].

### CAUTION

- Please be aware that the formerly-registered frequency in the memory will be overwritten.

### NOTE

- Separate to normal reception preset keys, this registers in preset keys in the AUTO-P mode.
- Pressing the preset key will select the previously registered frequency.
- Each time the AUTO-P key is pressed, this switches between normal reception and AUTO-P mode.
- In the AUTO-P mode, manual/seek station selection, as well as scan operation is also possible.

## Listen to CDs

E00737801216

This explains how to listen to audio CDs (CD-DA/CD-TEXT).

### Play CDs

Insert the disc.

Insert a disc to automatically start playback.

→ “Insert/Eject Discs” (P.7-47)

If a disc is already within the product, press the MEDIA key to switch to CD as the source.

### Select the Track

Press the ◀◀ key or ▶▶ key to select the track.

This enables selection of the next or previous track.

### Fast Forward or Rewind

Hold down the 3 ◀◀ key or the 4 ▶▶ key.

Fast forward/rewind is possible.

### Switch Playback Mode

Repeat playback, random playback, and scan playback are possible.

#### Repeat Playback (RPT)

Press the 1RPT key.

Repeat playback of the track currently being played.

#### NOTE

- Pressing again will cancel.
- Selecting a track, ejecting, fast forwarding, or rewinding will cancel.

#### Random Playback (RDM)

Press the 2RDM key.

Play the tracks on the disc in a random order.

#### NOTE

- Pressing again will cancel.
- Ejecting will cancel this.

### Scan Playback (SCAN)

Press the SCAN key.

Play the first 10 seconds of each of the tracks on the whole disc in order.

#### NOTE

- Press this button again during playback if you wish to hear that track, and that track will play normally.

7

## Listen to MP3s

E00737901190

This explains how to listen to audio files on a disc.

#### CAUTION

- CD-ROM and CD-R/RW media can only play back MP3 format audio files.

### To Listen to MP3s

Insert the disc.

Insert a disc to automatically start playback.

→ “Insert/Eject Discs” (P.7-47)

## Listen to MP3s

If a disc is already within the product, press the MEDIA key to switch to CD as the source.

### NOTE

- Depending on the file structure, it may take some time to read the contents of the disc.

## Select the Track (File)

7

Press the **1◀◀** key or **▶▶1** key to select the track.

This enables selection of the next or previous track.

## Fast Forward or Rewind

Hold down the **3◀◀** key or the **4▶▶** key.

Fast forward/rewind is possible.

## Switch Playback Mode

Repeat playback, random playback, and scan playback are possible.

## Repeat Playback (RPT)

Press the **1RPT** key.

Repeat playback of the track currently being played.

### NOTE

- Pressing again will cancel.
- Selecting a file, ejecting, fast forwarding, or rewinding will cancel.

## Folder Repeat Playback

Hold down the **1RPT** key.

Repeat playback of the tracks within the folder currently being played.

### NOTE

- Pressing again will cancel.
- Even if the file is selected, folder repeat playback will not be cancelled.

## Random Playback (RDM)

Press the **2RDM** key.

Play the tracks in the folder in a random order.

### NOTE

- Pressing again will cancel.

## Folder Random Playback

Hold down the **2RDM** key.

Play all tracks in folders on the disc in a random order.

### NOTE

- Pressing again will cancel.

## Scan Playback (SCAN)

Press the **SCAN** key.

Play the first 10 seconds of each of the tracks in the folder currently being played in order.

## Search Tracks

Search folders and files, and select a track.

1. Turn the **♪/SEL** key to select the folder.
2. Press the **♪/SEL** key.

Files within the selected folder are displayed.

3. Turn the **▶/SEL** key to select the file.
4. Press the **▶/SEL** key.

This plays the selected file (track).

#### NOTE

- While the folder is selected, press the **6 ↵** key to cancel track search mode.
- If there is no operation for 10 seconds after selecting the folder, then track search mode will be cancelled.
- Select the folder, and hold down the **▶/SEL** key to start playback from the first track in that folder.
- While the file is selected, press the **6 ↵** key to return to the previous operation.
- While the file is selected, hold down the **6 ↵** key to cancel track search mode.
- If there is no operation for five seconds after selecting the file, that file is played back.
- Disc operations such as selecting a track will cancel track search mode.

### Listen to an iPod\*

E00738001521

By connecting commercially-available iPod/iPhone devices to this product, you can play back tracks on these through the product.

#### CAUTION

- Do not leave the iPod/iPhone unattended in the vehicle.
- Never hold these devices in your hand to operate while driving, as this is dangerous.
- No indemnification for data loss resulting when the iPod/iPhone is connected to the product will be possible.
- Depending on how the devices are handled, audio files being damaged or lost, therefore it is recommended that data be backed up.

#### NOTE

- Depending on the generation, model, or software version of the iPod/iPhone, playback on this product may not be possible. (→P.7-38) Additionally, playback as explained in this document may not be possible.
- Usage of iPod/iPhone hardware with the latest software version is recommended.
- Regarding how to connect the iPod/iPhone, refer to “How to connect an iPod” on page 7-65.
- When connecting the iPod/iPhone, use a commercially-available iPod connection cable.
- Set up the device in order that no unsafe actions, such as plugging in the connection cable are taken while driving.

#### NOTE

- When inserting and removing the iPod/iPhone, for safety's sake first stop the vehicle.
- Depending on the status of the iPod/iPhone, it may take some time until the device is recognized, or playback starts.
- Depending on the iPod/iPhone, the button functions on the product may not operate while the iPod/iPhone is connected.
- iPod/iPhone specifications and settings may mean that connection is not possible, or result in differences in operation or display.
- Depending on audio data in the iPod/iPhone, track information may not be displayed correctly.
- Depending on the status of the vehicle and device, the iPod/iPhone may not play back after starting the engine.
- Data containing copyright information may not play back.
- It is recommended that the iPod/iPhone equaliser settings be set to flat.
- Operate the iPod/iPhone while connected to this product.
- If an iPod/iPhone does not operate correctly, then remove the iPod/iPhone from the product, reset, then reconnect.

#### Play iPod

Press the **MEDIA** key to set the iPod as the source.

For pleasant driving 7-53

Listen to an iPod\*

The selected source is indicated on the display.

### Select the Track (File)

Press the ◀◀ key or ▶▶ key to select the track.

This enables selection of the next or previous track.

7

### Fast Forward or Rewind

Hold down the 3◀◀ key or the 4▶▶ key.

Fast forward/rewind is possible.

### Switch Playback Mode

Repeat playback and shuffle playback are possible.

### Repeat Playback (RPT)

Press the 1RPT key.

Repeat playback of the track currently being played.

#### NOTE

- Pressing again will cancel.

### Shuffle Playback (RDM)

Press the 2RDM key.

Play tracks in the category currently being played in a random order.

#### NOTE

- Pressing again will cancel.

### Album Shuffle Playback

Hold down the 2RDM key.

Play back the album in a random order (tracks in any order on the album).

#### NOTE

- Pressing again will cancel.

### Search Tracks

Search categories or track names, and select a track.

1. Turn the ⏮/SEL key to select the category.
2. Press the ⏮/SEL key. Categories or tracks within the selected category are displayed.
3. Turn the ⏮/SEL key to select the category or track.
4. Press the ⏮/SEL key.  
Repeat steps 1 to 4, and search for tracks.  
Select the track, and press the ⏮/SEL key to play.

#### NOTE

- While the category (1st level) is selected, press the 6 ⏮ key to cancel track search mode.
- If there is no operation for 10 seconds after selecting the category, then track search mode will be cancelled.
- Select the category, and hold down the ⏮/SEL key to start playback from the first track in that category.
- While the track is selected, press the 6 ⏮ key to return to the previous operation.
- While the track is selected, hold down the 6 ⏮ key to cancel track search mode.
- If there is no operation for five seconds after selecting the track, that file is played back.
- iPod operations such as selecting a track will cancel track search mode.

## Listen to Audio Files on a USB Device\*

E00736501535

By connecting commercially-available USB devices such as USB memory to this product, you can play back audio files on these through the product.

### CAUTION

- Do not leave the USB device unattended in the vehicle.
- Never hold these devices in your hand to operate while driving, as this is dangerous.
- Do not use hard discs, card readers, or memory readers, as damage may occur to these or to the data contained therein. If these are erroneously connected, then turn the ignition switch to the “LOCK” position or put the operation mode in OFF, then remove.
- Because of the risk of data loss, it is recommended that files be backed up.
- No guarantee is made as regards damage to the USB device, nor regarding loss or damage to data contained therein.
- Depending on how the devices are handled, audio files being damaged or lost, therefore it is recommended that data be backed up.

### NOTE

- Digital audio players that support the mass storage class specifications can be connected.
- Regarding how to connect USB devices, refer to “How to connect a USB memory device” on page 7-64.
- When connecting a USB device, use a connection cable. Failure to use a connection cable when connecting may place undue load on, or damage the USB connector.
- Set up the device in order that no unsafe actions, such as plugging in the connection cable are taken while driving.
- When inserting and removing the USB device, for safety’s sake first stop the vehicle.
- Do not insert other than audio devices into the USB port. Damage to the device or equipment may result.
- Depending on the status of the USB device, it may take some time until the device is recognized, or playback starts.
- Depending on the USB device, the button functions on the product may not operate while the USB device is connected.
- USB device specifications and settings may mean that connection is not possible, or result in differences in operation or display.
- Depending on audio data in the USB device, track information may not be displayed correctly.

## Listen to Audio Files on a USB Device\*

### NOTE

- Depending on the status of the vehicle and device, the iPod/iPhone may not play back after starting the engine.
- Data containing copyright information may not play back.
- This product can play back MP3, WMA, and AAC format audio files.
- Depending on the type of USB device, usage may not be possible, or functions that can be used may be restricted.
- The recommended file system for USB memory is FAT32.
- The maximum supported capacity for USB memory is 32GB.
- Operate the USB device containing recorded audio files while connected to this product.

7

## Play Back of Audio Files on a USB Device

Press the MEDIA key to set

USB as the source. The selected source is indicated on the display.

### Select the Track (File)

Press the ◀◀ key or ▶▶ key to select the track.

## Listen to Audio Files on a USB Device\*

This enables selection of the next or previous track.

### Fast Forward or Rewind

Hold down the 3◀◀ key or the 4▶▶ key.

Fast forward/rewind is possible.

7

### Switch Playback Mode

Repeat playback, random playback, and scan playback are possible.

### Repeat Playback (RPT)

Press the 1RPT key.

Repeat playback of the track currently being played.

#### NOTE

- Pressing again will cancel.
- Selecting a file will cancel this.

### Folder Repeat Playback

Hold down the 1RPT key.

7-56 For pleasant driving

Repeat playback of the tracks within the folder currently being played.

#### NOTE

- Pressing again will cancel.
- Even if the file is selected, folder repeat playback will not be cancelled.

### Folder Random Playback (RDM)

Press the 2RDM key.

Play tracks in the folder currently being played in a random order.

#### NOTE

- Pressing again will cancel.
- Even if the file is selected, folder random playback will not be cancelled.

### All Folder Random Playback

Hold down the 2RDM key.

Play the tracks in all folders in a random order.

#### NOTE

- Pressing again will cancel.

#### NOTE

- Even if the file is selected, all folder random playback will not be cancelled.

### Scan Playback (SCAN)

Press the SCAN key. Play the first 10 seconds of each of the tracks on the whole USB device in order.

#### NOTE

- Press this button again during playback if you wish to hear that track, and that track will play normally.

### Folder Scan Playback

Hold down the SCAN key.

Play the first 10 seconds of the first track in each folder on the USB device in order.

#### NOTE

- Press this button again during playback if you wish to hear that track, and that track will play normally.

## Search Tracks

Search folders and files, and select a track.

1. Turn the **▶/SEL** key to select the folder.
2. Press the **▶/SEL** key.

Files within the selected folder are displayed.

3. Turn the **▶/SEL** key to select the file.
4. Press the **▶/SEL** key.

This plays the selected file (track).

### NOTE

- While the folder is selected, press the **6 ↵** key to cancel track search mode.
- If there is no operation for 10 seconds after selecting the folder, then track search mode will be cancelled.
- Select the folder, and hold down the **▶/SEL** key to start playback from the first track in that folder.
- While the file is selected, press the **6 ↵** key to return to the previous operation.
- While the file is selected, hold down the **6 ↵** key to cancel track search mode.

### NOTE

- If there is no operation for five seconds after selecting the file, that file is played back.
- Operations such as selecting a track will cancel track search mode.

## Display Indicator

E00738101199

This explains content of the display indicator.



## Display Indicator

7



### Change the Display Mode

E00738501119

You can change the content of the display indicator.

Press the DISP key to switch the display content.

Each time the DISP key is pressed, the display content changes.

#### CAUTION

- The operation of changing display contents may impede safe driving, therefore check safety before operation.

#### NOTE

- Up to 11 characters may be displayed at one time. To display 12 or more characters, press the PAGE key, and subsequent characters will be displayed.

### During CD-DA playback

This switches in the order “Disc title”, “Track title”, and “Operating status”.

#### NOTE

- If there is no text information to display, then “NO TITLE” is displayed.

### During MP3/WMA/AAC Playback

This switches in the order “Folder title”, “File title”, and “Operating status”.

#### NOTE

- If there is no text information to display, then “NO TITLE” is displayed.

### Display the ID3tag

Hold down the DISP key.

This switches the ID3tag display.

[DISP] Each time the key is pressed, this switches in the order “Album name”, “Track name”, “Artist name”, and “Operating status”.

**NOTE**

- During display of the ID3tag, hold down the DISP key to switch to the folder title display.

**During iPod Playback**

E00738901197

This switches in the order “Albums”, “Track name”, “Artist name”, and “Operating status”.

**NOTE**

- If there is no text information to display, then “NO TITLE” is displayed.

**Audio Quality and Volume Balance Adjustment**

E00738201389

Change audio quality settings.

**Adjust Audio Quality and Volume Balance**

1. Press the **▶**/SEL key to select settings items.

Each time the **▶**/SEL key is pressed, this switches in the order BASS, TREBLE, FADER, BALANCE, SCV (speed compensated volume), and Cancel.

2. Turn the **▶**/SEL key to adjust.

Adjustment items	Turn counter-clockwise	Turn clockwise
BASS	-6 to 0 (Decrease low frequency volume)	0 to +6 (Increase low frequency volume)
TREBLE	-6 to 0 (Decrease high frequency volume)	0 to +6 (Increase high frequency volume)
FADER	CENTER to REAR 11 (emphasise REAR)	FRONT 11 to CENTER (emphasise FRONT)

Adjustment items	Turn counter-clockwise	Turn clockwise
BALANCE	LEFT 11 to CENTER (emphasise LEFT)	CENTER to RIGHT 11 (emphasise RIGHT)
SCV	OFF, LOW (SCV effect is middle/high)	MID, HIGH (SCV effect is OFF/low)

**7**

**System Settings**

E00738301683

Change system settings such as product time.

1. Press the MENU key.
2. Press the **▶**/SEL key to select settings items.

Each time the **▶**/SEL key is pressed, this switches in the order PHONE settings, Adjust time, and Cancel.

3. Turn the **▶**/SEL key to set.
4. Press the **▶**/SEL key to determine.

This completes settings, and displays the next settings item.

## Troubleshooting

### Time Setting

Set the time manually.

1. Select “YES” at the “Adjust time” screen, and press the **▶**/SEL key.

The hour can be adjusted. Press the **▶**/SEL key again to adjust the minutes.

2. Turn the **▶**/SEL key to adjust the time.
3. Press the **▶**/SEL key.

This completes the adjustment.

#### NOTE

- In order to finish adjusting the time, hold down the **▶**/SEL key until the seconds are reset to “00”.

### PHONE Settings

Change mobile phone voice cut-in settings. Depending on the type of vehicle, PHONE settings may not be possible. A hands-free kit (available separately) is required. (“Set value” bold typeface indicates factory default settings.)

Settings value	Settings content
<b>PHONE OFF</b>	Do not use mobile phone voice cut-in.
PHONE MUTE	During mobile phone voice cut-in, mute the audio.

Settings value	Settings content
PHONE ATT	During mobile phone voice cut-in, output audio from all speakers.
PHONE IN-L	During mobile phone voice cut-in, output sound from the left front speaker.
PHONE IN-R	During mobile phone voice cut-in, output sound from the right front speaker.
PHONE IN-LR	During mobile phone voice cut-in, output sound from the left and right front speakers.

## Troubleshooting

E00738401219

Please check these items if a message appears on the display, or if you think something is not working properly.

### If This Message Appears...

A message is displayed on this product according to the situation.

Mode	Message	Cause	Response
CD	CHECK DISC	The disc is inserted upside down.	Insert with the label side up.
		The disc has condensation on it.	Wait a while before inserting again.
	DISC ERROR	The disc is damaged.	Clean the read surface of the disc.
		The disc is dirty.	
	INTERNAL E	The drive has malfunctioned for some reason.	Check that there is no problem with the disc, and insert the disc again. If the problem persists, consult an authorised MITSUBISHI MOTORS dealer.
HEAT ERROR	The temperature inside the product is high.	Remove the disc, and wait for the internal temperature to return to normal.	
USB	FILE ERROR	Files that cannot be played are selected.	Select files that can be played. → “Audio Files (MP3/WMA/AAC)” (P.7-42)
	USB BUS PWR	There is high or low electrical current or voltage.	Turn the power OFF and wait a short while. If the problem persists, consult an authorised MITSUBISHI MOTORS dealer.
	LSI ERROR	There is an internal malfunction for some reason.	
	UNSUPPORTED FORMAT	Unsupported audio files have been played.	Confirm audio files that can be played. → “Audio Files (MP3/WMA/AAC)” (P.7-42)
	UNSUPPORTED DEVICE	An unsupported USB device has been connected.	Please connect a USB memory device.
iPod	NO SONG	An iPod/iPhone not containing any tracks has been connected.	Connect an iPod/iPhone containing tracks.
	VER ERROR	This iPod/iPhone software version is not supported.	Please change to a supported software version.
Other	ERROR DC	An abnormal direct voltage has been sent to the speakers.	Turn the power OFF and wait a short while. If the problem persists, consult an authorised MITSUBISHI MOTORS dealer.

## Antenna

### If You Think Something Is Not Working Properly...

Here is a list of symptoms, causes and responses if you think something is not working properly.

Symptoms	Cause	Response
There is no sound or quiet sound.	The volume is turned to its minimum.	Adjust the volume. → “Adjust Volume” (P.7-47)
	The balance or fader is turned to one side.	Adjust the balance or fader. → “Adjust Audio Quality and Volume Balance” (P.7-59)
The disc cannot be inserted.	A disc is already in the product.	Eject the disc. → “Insert/Eject Discs” (P.7-47)
	There is no disc in the product, but the product says it is loading.	Press the eject button once. → “Insert/Eject Discs” (P.7-47)
The disc cannot be played.	The disc is inserted upside down.	Insert with the label side up.
	The disc has condensation on it.	Wait a while before inserting.
	The disc is dirty.	Clean the read surface of the disc.
The sound skips in the same place.	The disc is damaged or dirty.	Check the disc.
There is no sound, even if the disc is inserted.	Damage to or dirt on the disc means that its data cannot be read.	Check the disc. Additionally, if using CD-R/RW discs, their characteristics may render them unable to be played.

## Antenna

E00710500022

antenna.

## Pillar antenna\*

E00710701164

When listening to the radio, fully extend the

7-62 For pleasant driving

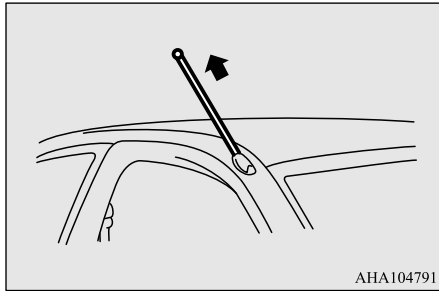

AHA104791

**NOTE**

- Be sure to retract the pillar antenna in the following cases:
  - When entering a place with low clearance.
  - When going into an automatic car wash.
  - When placing a car cover over the vehicle.

**Roof antenna\***

E00710901212

When listening to the radio, raise the antenna up until you hear it click.

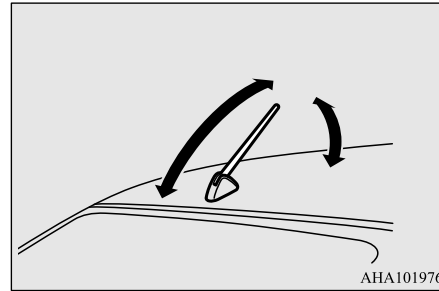

AHA101976

**To remove**

Turn the pole (A) anticlockwise.

**To install**

Screw the pole (A) clockwise into the base (B) until it is securely retained.

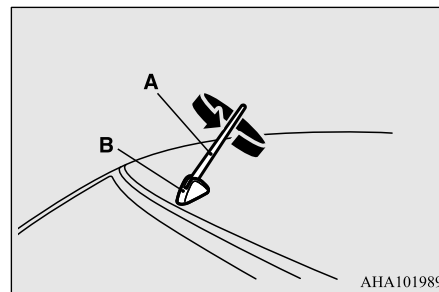

AHA101989

**NOTE**

- Be sure to remove the roof antenna in the following cases:
  - When going into an automatic car wash.
  - When placing a car cover over the vehicle.
  - When driving into a structure that has a low ceiling.

**Link System\***

E00764501804

The Link System takes overall control of the devices connected via the USB input terminal allowing the connected devices to be operated by using the switches in the vehicle.

See the following section for details on how to operate.

Refer to “USB input terminal” on page 7-64.

Refer to “Listen to an iPod” on page 7-29, 7-53.

Refer to “Listen to Audio Files on a USB Device” on page 7-31, 7-55.

Refer to “Use AUX” on page 7-33.

## USB input terminal\*

### USB input terminal\*

E00761902051

You can connect your USB memory device or iPod\* to play music files stored in the USB memory device or iPod.

\*: "iPod" is a registered trademark of Apple Inc. in the United States and other countries.

**7**

The USB input terminal (A) is located in the indicated position.

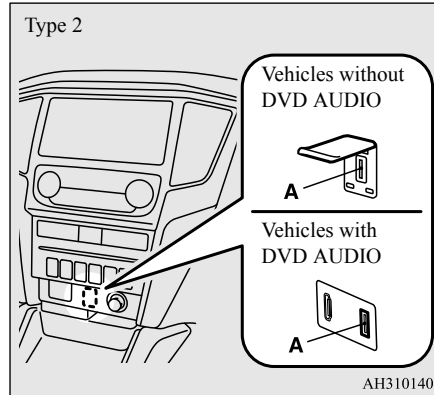
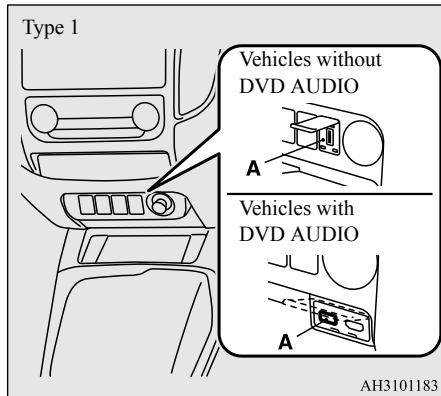

This section explains how to connect and remove a USB memory device or iPod.

See the following section for details on how to play music files.

Refer to the following sections for details on how to play music files:

Refer to "Listen to an iPod" on page 7-29, 7-53.

Refer to "Listen to Audio Files on a USB Device" on page 7-31, 7-55.

### How to connect a USB memory device

E00762002020

1. Park your vehicle in a safe place and turn the ignition switch to the "LOCK" position or put the operation mode in OFF.
2. Open the USB input terminal cover (A) (if so equipped) on the centre console.

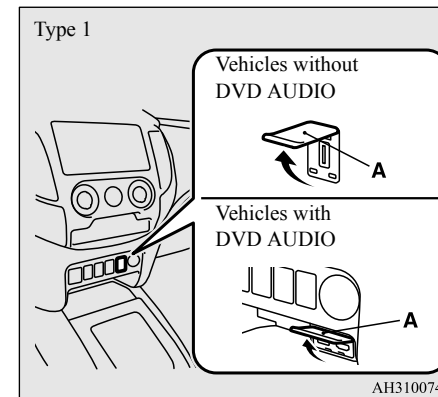

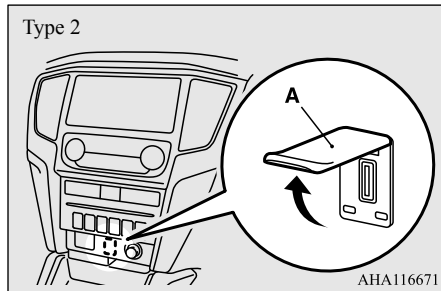

3. Connect a commercially available USB connector cable (C) to the USB memory device (B).

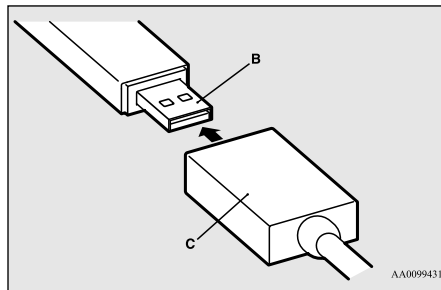

4. Connect the USB connector cable to the USB input terminal.

**NOTE**

- Do not connect the USB memory device to the USB input terminal directly. The USB memory device may be damaged.

5. To remove the USB connector cable, turn the ignition switch to the “LOCK” position or put the operation mode in OFF first and perform the installation steps in reverse.

**CAUTION**

- After removing the USB connector cable, be sure to close the terminal cover (if so equipped). Entry of foreign matter into the terminal may cause a malfunction.

**How to connect an iPod**

E00762102089

1. Park your vehicle in a safe place and turn the ignition switch to the “LOCK” position or put the operation mode in OFF.
2. Open the USB input terminal cover (A) (if so equipped) on the centre console.

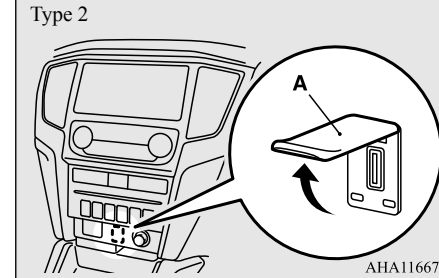
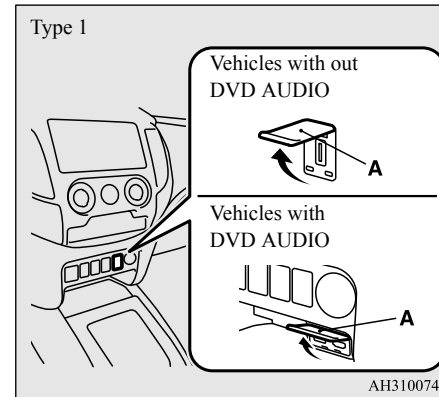

3. Connect the connector cable to the iPod.

**NOTE**

- Use a genuine connector cable from Apple Inc.



## HDMI terminal\*

4. Connect the connector cable to the USB input terminal.
5. To remove the connector cable, turn the ignition switch to the “LOCK” position or put the operation mode in OFF first and perform the installation steps in reverse.

### CAUTION

- After removing the connector cable, be sure to close the terminal cover (if so equipped). Entry of foreign matter into the terminal may cause a malfunction.

7

## Types of connectable devices and supported file specifications

E00762201777

For details about the types of connectable devices and supported file specifications, refer to the following pages.

### For vehicles equipped with the AM/FM radio/CD player with AUX

Refer to “Listen to an iPod” on page 7-29, “Listen to Audio Files on a USB Device” on page 7-31 and “Audio Files (MP3/WMA/AAC)” on page 7-19.

### For vehicles equipped with the AM/FM radio/CD player

Refer to “Listen to an iPod” on page 7-53, “Listen to Audio Files on a USB Device” on page 7-55 and “Audio Files (MP3/WMA/AAC)” on page 7-42.

### For vehicles equipped with the DVD AUDIO

Refer to the separate owner’s manual.

## HDMI terminal\*

E00771400231

You can connect a commercially available HDMI device such as a video camera and a smart phone to the HDMI terminal (A).

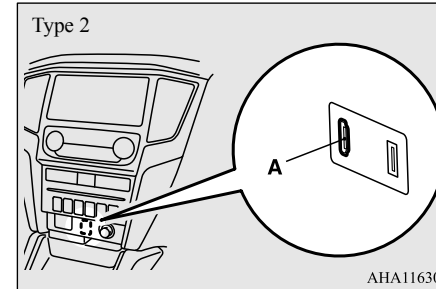
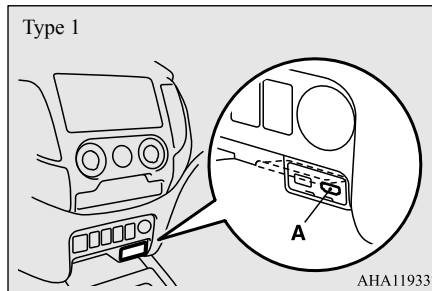

### NOTE

- For details, refer to the separate owner’s manual for a DVD AUDIO.

## To connect

1. Park your vehicle in a safe place and turn the ignition switch to the “LOCK” position or put the operation mode in OFF.
2. Open the terminal cover (A) (if so equipped) on the centre console.

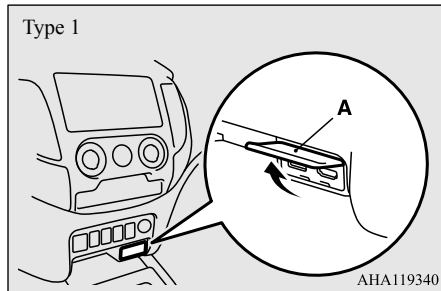

3. Connect a commercially available HDMI cable to the HDMI device.
4. Connect a HDMI cable to the HDMI terminal.
5. To remove the HDMI cable, perform the installation steps in reverse.

**⚠ CAUTION**

- After removing the HDMI cable, be sure to close the terminal cover (if so equipped). Entry of foreign matter into the terminal may cause a malfunction.

**Sun visors**

E00711202538

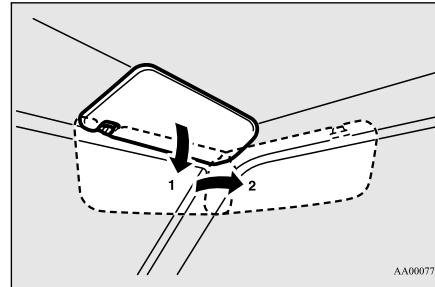

- 1- To eliminate front glare
- 2- To eliminate side glare

**Card holder\***

Cards can be slipped into the holder (A) on the back of the sunvisor.

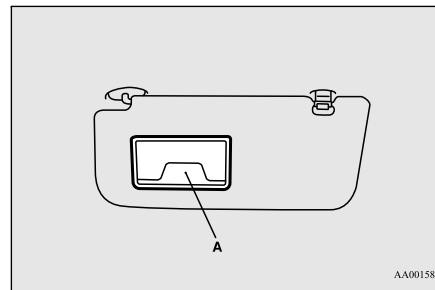

**Vanity mirror\***

E00711301747

A vanity mirror is fitted to the back of the sun visor on the passenger side.

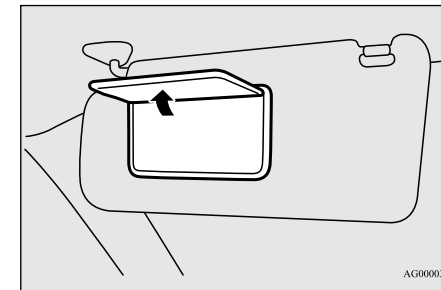

**7**

**Ashtray\***

E00711402501

**⚠ CAUTION**

- Put out matches and cigarettes completely before they are placed in the ashtray.
- Don't put papers and other things that burn into your ashtrays. If you do, cigarettes or other smoking materials could set them on fire, causing damage.
- Always close the ashtray. If left open, other cigarette butts in the ashtray may be rekindled.

Cigarette lighter\*

**Type 1 (fixed position)**

To use the ashtray, pull it out.

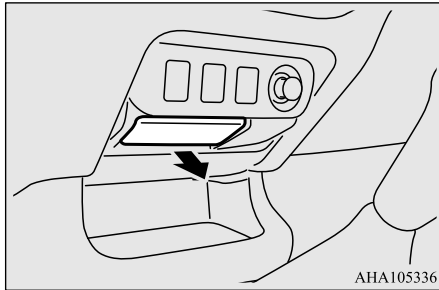

**7**

To remove the ashtray, pull it out while pressing the stop (A).

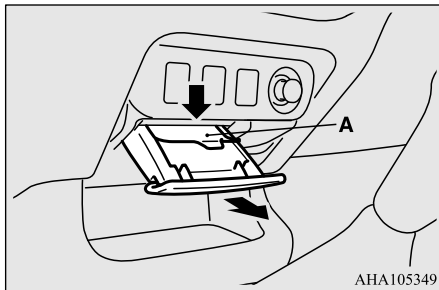

**Type 2 (movable)**

To use the movable ashtray, open the lid.

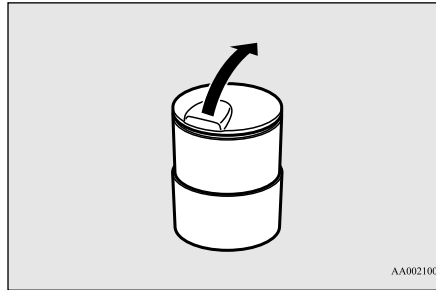

**Mounting position for movable ashtray**

The movable ashtray can be installed in the cup holder.

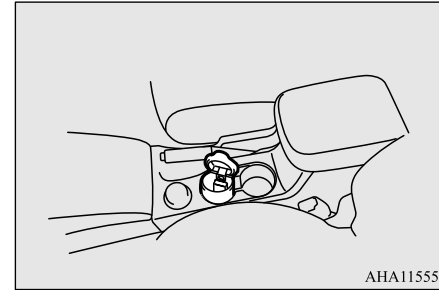

**Cigarette lighter\***

E00711502573

The cigarette lighter can be used while the ignition switch is in either "ON" or "ACC".

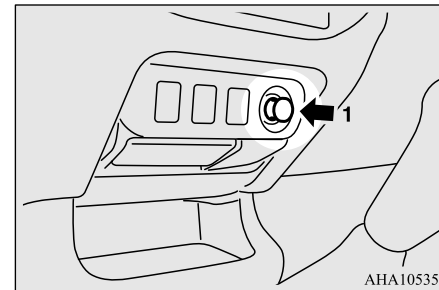

1- Push all the way in.

## Accessory socket\*

The cigarette lighter will automatically return to its original position with a “click” when ready. Pull it out for use.

After use, insert the cigarette lighter to its original position in the socket.

### NOTE

- Do not leave the cigarette lighter removed from its socket, because the socket might become clogged by foreign material and be short-circuited.

### CAUTION

- Do not touch the heating element or the cigarette lighter housing, hold the knob only to prevent burns.
- Do not allow children to operate or play with the cigarette lighter as burns may occur.
- Something is wrong with the cigarette lighter if it does not pop back out within approximately 30 seconds of being pushed in. Pull it out and have the problem corrected at an authorised MITSUBISHI MOTORS dealer.
- Do not use any electric appliance that is not approved by MITSUBISHI MOTORS. Doing so could damage the socket. If you used the cigarette lighter after damaging the socket, the cigarette lighter might pop out or fail to come out after being pushed in.

### CAUTION

- When the cigarette lighter socket is used as a power source for an electric appliance, be sure that the electric appliance operates at 12 V and has an electric capacity of 120 W or less. In addition, long use of the electric appliance without running the engine may run down the battery.

## Accessory socket\*

E00711603193

### CAUTION

- Be sure to use a “plug-in” type accessory operating at 12 V and at 120 W or less. When using more than one socket at the same time, make sure that the electrical accessories are 12 V accessories and that the total power consumption does not exceed 120 W.
- Long use of the electric appliance without running the engine may run down the battery.
- When the accessory socket is not in use, be sure to close the lid or install the cap, because the socket might become clogged by foreign material and be short-circuited.

To use a plug-in type accessory, open the lid or remove the cap, and insert the plug in the accessory socket.

### NOTE

- Accessory sockets in 2 locations can be used at the same time.

The accessory socket can be used while the ignition switch or the operation mode is in ON or ACC.

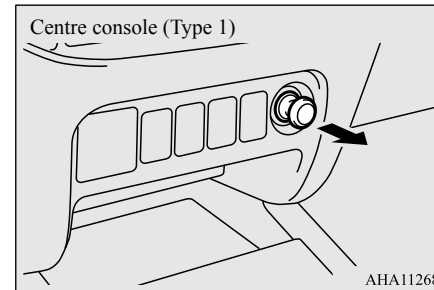

7

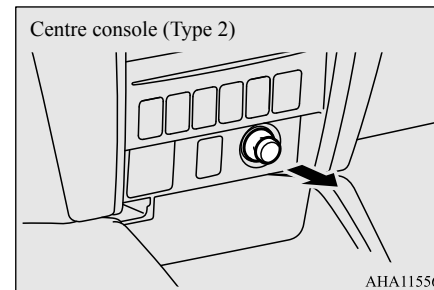

## USB port (for charging)\*

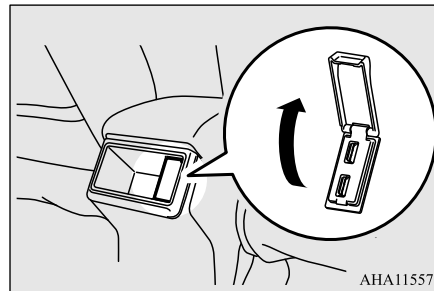
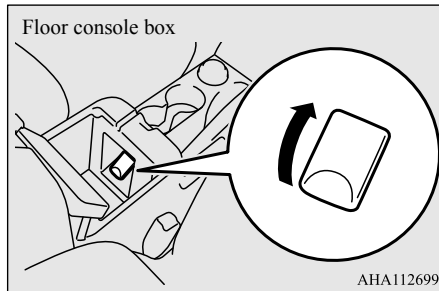

7

### USB port (for charging)\*

E00778300079

The USB port (for charging) can be used as a power source of the USB appliances when the ignition switch or the operation mode is in ON or ACC.

There are two USB ports (for charging) located on the back of the floor console box. When using the USB port (for charging), open the lid and connect the USB connector cable to it.

### CAUTION

- When the USB port (for charging) is not in use, be sure to close the lid, because the USB port (for charging) might be short-circuited by clogging foreign materials and the connected devices and the USB port (for charging) might be damaged.
- Insert the USB connector cable in the USB port (for charging) firmly. If the USB connector cable does not insert in it firmly, it may become extremely hot and the fuses may blow.
- Be sure that the power consumption does not exceed 10.5 W {The peak outlet current or voltage of the USB port (for charging) is DC 5 V-2.1 A}. The connected devices or the USB port (for charging) may be damaged.

### CAUTION

- Do not use the reversible USB connector cable that the USB connector board is located in the centre. The USB port (for charging) might be damaged.
- Long use of the electric appliance without running the engine may run down the battery.

### NOTE

- These USB ports (for charging) can be used only as a power source. They do not connect to the audio devices of the vehicles.
- Do not charge many mobile devices together by using a multi-plug adapter of the USB port (for charging).
- If water or spill beverages has splashed on the USB ports (for charging), stop using it and have the vehicle checked by an authorised MITSUBISHI MOTORS dealer.

### Interior lamps

E00712002793

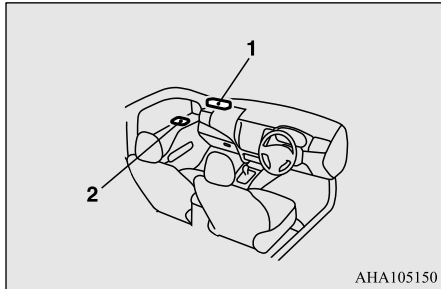

AHA105150

- 1- Front room & map lamps\*
- 2- Rear room lamp\*  
Rear personal lamps\*

### NOTE

- If you leave the lamps on without running the engine, you will run down the battery. Before you leave the vehicle, make sure that all the lamps are off.

### Room lamps/Rear personal lamps

E00712102879

#### Room lamps

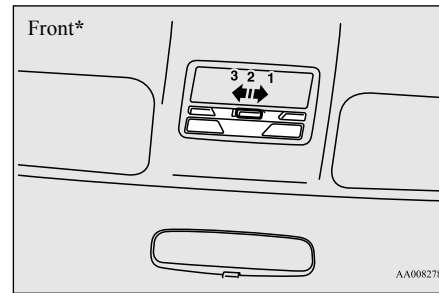

AA0082787

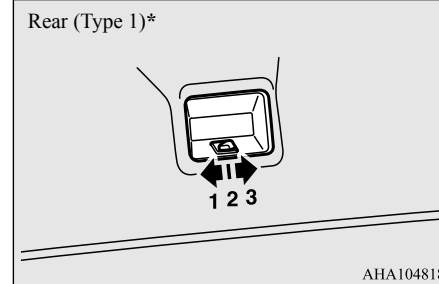

AHA104818

Rear (Type 2)\*

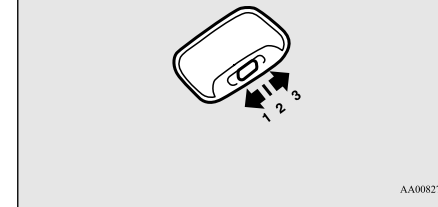

AA0082790

#### Rear personal lamps

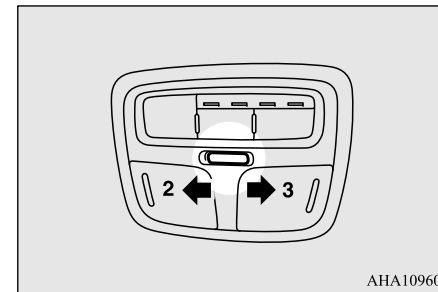

AHA109608

7

Position of lamp switch	On/off control
1-ON (  )	The lamp illuminates regardless of whether a door is open or closed.

Interior lamps

7

Position of lamp switch	On/off control
2-DOOR (●)	<p><b>Delayed off function</b> [Vehicles without central door lock system] The lamp illuminates when a door is opened. It goes off approximately 7 seconds after all doors are closed. However, the lamp goes off immediately when the ignition switch is turned to the “ON” position with all doors closed. [Vehicles with central door lock system] The lamp illuminates when a door is opened. It goes off approximately 15 seconds after the all doors are closed. However, the lamp goes off immediately with all doors closed in the following cases:</p>

Position of lamp switch	On/off control
	<ul style="list-style-type: none"> <li>● When the ignition switch is turned to the “ON” position or the operation mode is put in ON.</li> <li>● When the central door lock function is used to lock the vehicle.</li> <li>● When the keyless entry key or the keyless operation key is used to lock the vehicle.</li> <li>● If the vehicle is equipped with the keyless operation system, when the keyless operation function is used to lock the vehicle.</li> </ul>

Position of lamp switch	On/off control
	<p><b>Auto cut-out function</b> If the lamp is left switched on with the ignition switch is in the “LOCK” or “ACC” position or the operation mode is in OFF or ACC, and a door is opened, it goes off automatically after approximately 30 minutes. The lamp will illuminate again after it automatically goes off in the following cases:</p> <ul style="list-style-type: none"> <li>● When the ignition switch is turned to the “ON” position or the operation mode is put in ON.</li> <li>● When the keyless entry system or the keyless operation system is operated.</li> <li>● When all doors are closed.</li> </ul>
3-OFF (○)	The lamp goes off regardless of whether a door is open or closed.

 **NOTE**

- On vehicles without central door lock system, when the ignition key is removed while the doors are closed, the lamp is illuminated and after a few seconds it goes off.

**NOTE**

- On vehicles with central door lock system, when the ignition key is removed or the operation mode is put in OFF while the doors are closed, the lamp illuminates and after approximately 15 seconds it goes off.
- The time until the lamp goes off (delayed off) can be adjusted. For details, please consult an authorised MITSUBISHI MOTORS dealer.
- The auto cut-out function cannot be operated when the room lamp switch is in the "ON" or "☀️" position. Also, this function can be deactivated. For details, please consult an authorised MITSUBISHI MOTORS dealer.

**Map lamps**

E00712401178

Push the switch (A) to turn on the lamp. Push it again to turn it off.

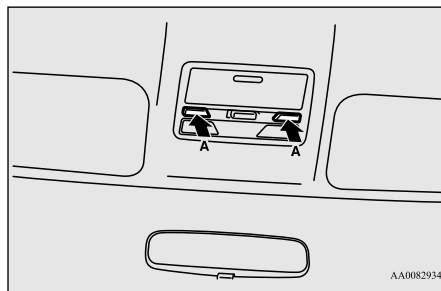

AA0082934

**Rear personal lamps\***

E00712601617

Push the lens (A) to turn on the lamp. Push it again to turn it off.

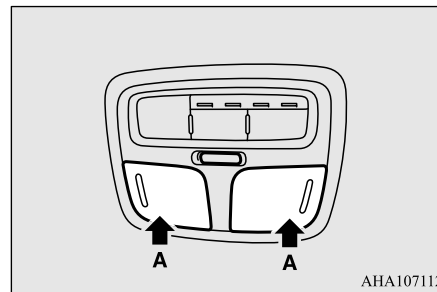

AHA107112

**Storage spaces**

E00713103163

**CAUTION**

- Never leave lighters, canned carbonated beverage, and spectacles in the cabin when parking the vehicle in hot sunshine. The cabin will become extremely hot, so lighters and other flammable items may catch fire and unopened drink cans may rupture. Also, spectacles with plastic lenses or materials could deform or crack.

**CAUTION**

- Keep the lids of storage spaces closed while driving the vehicle. A lid or the contents of a storage space could otherwise cause injuries.

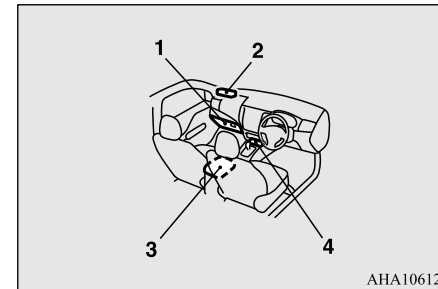

AHA106128

- 1- Glove box
- 2- Sunglasses holder\*
- 3- Floor console box\*
- 4- Centre console under tray\*

**7**

**Glove box**

E00717603052

To open, push the button (A).



## Storage spaces

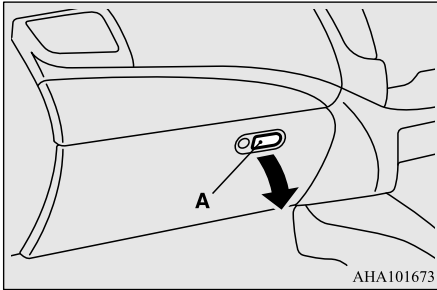

7

### NOTE

- When the lamps are illuminated with the lamp switch in the “

### Centre console under tray\*

E00748600220

The centre console under tray is on the floor console part.

### NOTE

- Do not use the centre console under tray as an ashtray. This could cause a fire or the tray will be damaged.

### Type 1

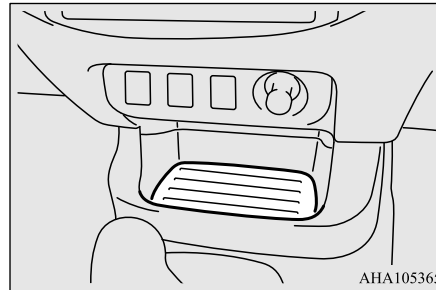

### Type 2

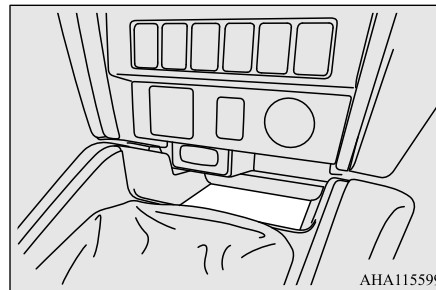

### Type 3

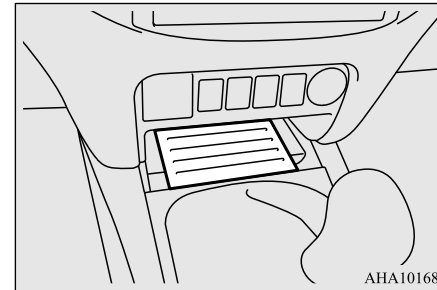

### NOTE

- The centre console under tray is removable, so it is also possible to use as storage space.

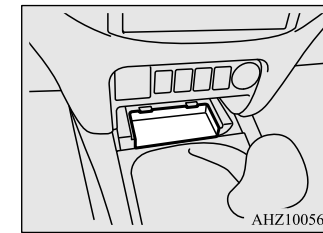

**NOTE**

- When using a commercially available USB connector cable connected to the USB input terminal or commercially available HDMI connector cable connected to the HDMI input terminal, if you hold up extra length of the cable in the storage space and install the tray, you can use only the necessary length cable pulled out from the storage space.

**Floor console box\***

E00723302464

**CAUTION**

- Keep the lid of floor console box closed while driving the vehicle. If the brakes are applied suddenly, hands or fingers may be trapped because of closing the lid.

**Type 1**

Upper and lower boxes are located inside the floor console box.  
The floor console box can also be used as an armrest.

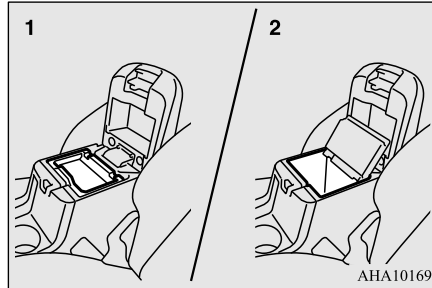

- 1- Upper box
- 2- Lower box

**Upper box**

To open the upper box, raise the lid.

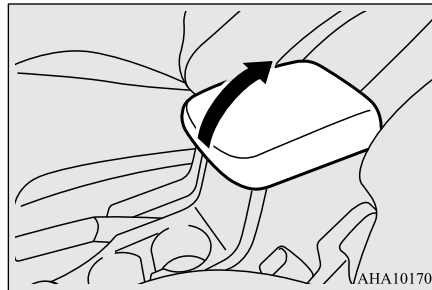

**Lower box**

To open the lower box, raise the upper box.

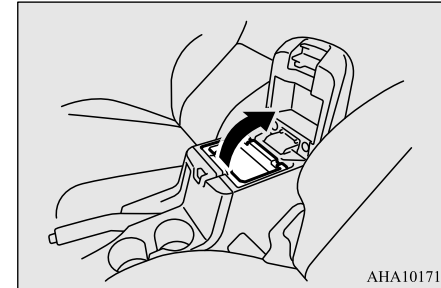

**NOTE**

- When opening or closing the lid, be careful not to trap hands.
- The upper box can be removed and use as a box.

**Type 2**

To open the console box, raise the lid.  
The floor console box can also be used as an armrest.

## Cup holder\*

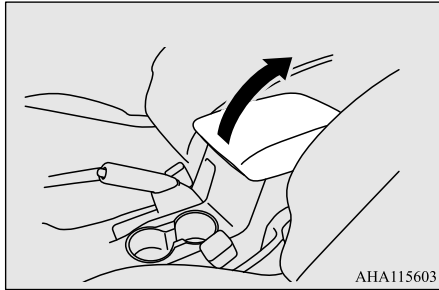

### ⚠ CAUTION

- The holder should not be used to store anything heavier than sunglasses. These objects could drop out.

### 📖 NOTE

- The holder may not be able to accommodate every possible size and shape of sunglasses; it is advisable to check compatibility before use.

7

## Sunglasses holder\*\*

E00718601404

To open, push the lid.

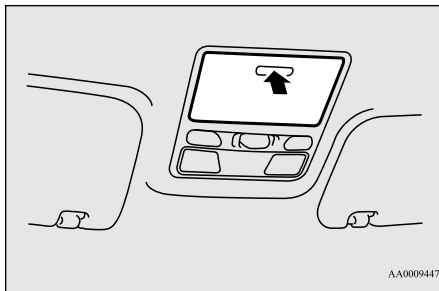

## Cup holder\*

E00714502330

### ⚠ WARNING

- Do not spray water or spill beverages inside the vehicle. If the switches, wires, or electrical components become wet, they could malfunction or cause a vehicle fire. If you accidentally spill a beverage, wipe up as much liquid as possible and immediately consult an authorised MITSUBISHI MOTORS dealer.

### ⚠ CAUTION

- Do not drink beverages while driving. This is distracting and could cause an accident.

## For the front seat

The cup holder is located between the front seats.

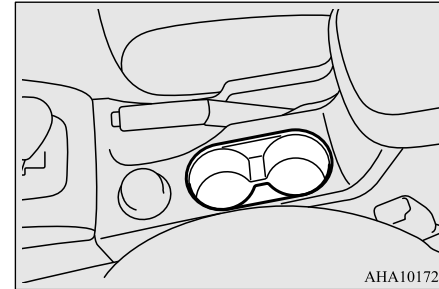

## For the rear seat

E00716901605

In order to use the cup holder, allow the armrest to drop down.

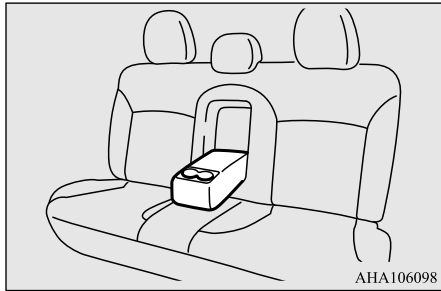

AHA106098

**Bottle holder**

E00718201514

**⚠ WARNING**

- Do not spray water or spill beverages inside the vehicle. If the switches, wires, or electrical components become wet, they could malfunction or cause a vehicle fire. If you accidentally spill a beverage, wipe up as much liquid as possible and immediately consult an authorised MITSUBISHI MOTORS dealer.

**⚠ CAUTION**

- Do not drink beverages while driving. This is distracting and could cause an accident.
- Drinks could be spilled by the vibration and jolts while driving. If the spilt drink is very hot, you could be burnt.

The bottle holders are provided at both sides of front and rear doors (if so equipped).

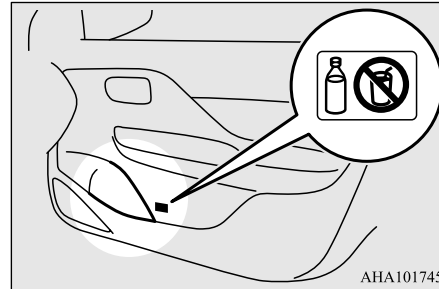

AHA101745

**📖 NOTE**

- Do not store cup or drink can in the bottle holder.
- Tightly close the cap on drink bottles before storing them.
- Some bottles may be too big or the wrong shape to fit in the holder.

**Convenient hook\***

E00732901212

Light items of luggage can be hung from the hook.

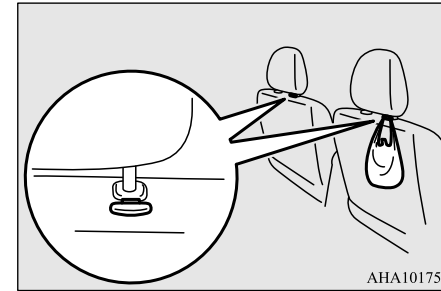

AHA101758

**📖 NOTE**

- Do not hang heavy luggage (more than about 4 kg) on the hook. Doing so could cause damage to the hook.

**Assist grip**

E00732801370

These grips are to support the body by hand while seated in the vehicle.

## Coat hook\*

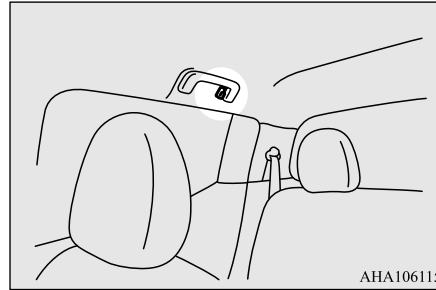
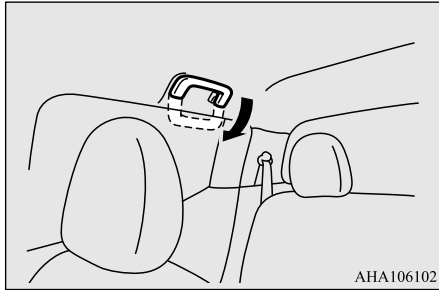

7

### **⚠ CAUTION**

- Do not use the assist grips when getting into or out of the vehicle. The assist grips could detach causing you to fall.

### **Coat hook\***

E00725601682

There is a coat hook on the rear seat assist grip.

### **⚠ WARNING**

- Do not put a hanger or any heavy or pointed object on the coat hook. If the curtain airbag was activated, any such item could be propelled away with great force and could prevent the curtain airbag from inflating correctly. Hang clothes directly on the coat hook (without using a hanger). Make sure there are no heavy or sharp objects in the pockets of clothes that you hang on the coat hook.

## *For emergencies*

If the vehicle breaks down .....	8-2
If the operation mode cannot be changed to OFF (vehicles equipped with the keyless operation system) .....	8-2
Emergency starting .....	8-2
Engine overheating .....	8-4
Bleeding the fuel system .....	8-5
Removal of water from the fuel filter .....	8-5
Tools, jack and jack handle .....	8-6
How to change a tyre .....	8-10
Towing .....	8-19
Operation under adverse driving conditions .....	8-23

If the vehicle breaks down

### If the vehicle breaks down

E00800101137

If the vehicle breaks down on the road, move it to the shoulder and use the hazard warning flashers and/or the warning triangle etc. Refer to “Hazard warning flasher switch” on page 5-60.

### If the engine stops/fails

8

Vehicle operation and control are affected if the engine stops. Before moving the vehicle to a safe area, be aware of the following:

- The brake booster becomes inoperative and the pedal effort will increase. Press down the brake pedal harder than usual.
- Since the power steering system is no longer operative, the steering wheel feels heavy when turning it.

### If the operation mode cannot be changed to OFF (vehicles equipped with the keyless operation system)

E00804900051

If the operation mode cannot be changed to OFF, perform the following procedure.

1. Move the selector lever to the “P” (PARK) position, and then change the operation mode to OFF. (For vehicles with A/T)
2. One of the other causes could be low battery voltage. If this occurs, the keyless entry system, keyless operation function, and steering lock will also not operate. Contact an authorised MITSUBISHI MOTORS dealer.

### Emergency starting

E00800504767

If the engine cannot be started because the battery is weak or dead, the battery from another vehicle can be used with jumper cables to start the engine.

### WARNING

- To start the engine using jumper cables from another vehicle, perform the correct procedures according to the instruction below. Incorrect procedures could result in a fire or explosion or damage to the vehicles.
- Keep sparks, cigarettes and flames away from the battery because the battery may produce an explosion.

### CAUTION

- Do not attempt to start the engine by pulling or pushing the vehicle. It could damage your vehicle.
- Check the other vehicle. It must have a 12-volt battery. If the other system isn't 12-volt, shorting can damage both vehicles.
- Use the proper cables suitable for the battery size to prevent overheating of the cables.
- Check the jumper cables for damage and corrosion before use.
- Always wear protective eye goggles when working near the battery.
- Keep the battery out of the reach of children.

1. Get the vehicles close enough so the jumper cables can reach, but be sure the vehicles aren't touching each other.
2. Turn off all lamps, heater and other electrical loads.
3. Set the parking brake firmly on each vehicle. Put an automatic transmission in “P” (PARK) or a manual transmission in “N” (Neutral). Stop the engine.

### WARNING

- Turn off the ignition on both vehicles beforehand. Make sure that the cables or your clothes cannot be caught by the fan or drive belt. Personal injury could result.

4. Make sure battery electrolyte is at the proper level.  
Refer to “Battery” on page 10-9.

**⚠ WARNING**

- If electrolyte fluid is not visible, or appears to be frozen, Do Not Attempt Jump Starting!  
A battery might rupture or explode if the temperature is below the freezing point or if it is not filled to the proper level.
- Electrolyte is corrosive diluted sulphuric acid.  
If electrolyte (battery acid) comes into contact with your hands, eyes, clothes or the painted surface of your vehicle, it should be thoroughly flushed with water. If electrolyte gets in your eyes, flush them with water immediately and thoroughly, and get prompt medical attention.

5. Connect one end of one jumper cable ① to the positive (+) terminal of the discharged battery (A), and the other end ② to the positive (+) terminal of the booster battery (B).  
Connect one end of the other jumper cable ③ to the negative (-) terminal of the booster battery (B), and the other end ④ to the engine block of the vehicle with the discharged battery at the point farthest from the battery.

**📖 NOTE**

- Open the terminal cover before connecting the jumper cable to the positive (+) terminal of the battery.  
(Refer to “Battery” on page 10-9.)

4D56

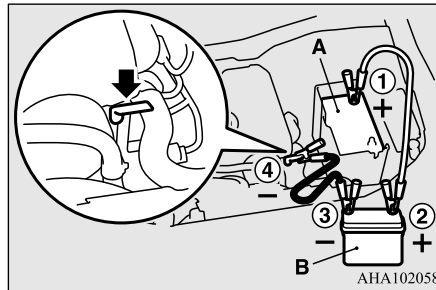

4N15

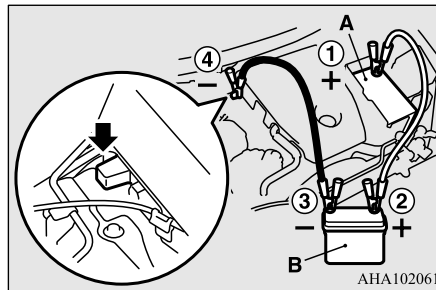

**⚠ WARNING**

- Make sure that the connection ④ is made to the appointed position (shown in the illustration). If the connection is made directly to the negative (-) side of the battery, the inflammable gases generated from the battery might catch fire and explode.
- When connecting the jumper cables, do not connect the positive (+) cable to the negative (-) terminal. Otherwise sparks might cause explosion of the battery.

**⚠ CAUTION**

- Use care not to get the jumper cable caught in the cooling fan or other rotating part in the engine compartment.

6. Start the engine in the vehicle which has the booster battery, let the engine idle a few minutes, then start the engine in the vehicle with the discharged battery.

**⚠ CAUTION**

- Keep the engine of the vehicle giving assistance running.



## Engine overheating

### NOTE

- For vehicles equipped with the Auto Stop & Go (AS&G) system, press the “Auto Stop & Go (AS&G) OFF” switch to deactivate the Auto Stop & Go (AS&G) system and prevent the engine from automatically stopping before the battery is sufficiently charged. Refer to “To deactivate” on page 6-27.

7. After the engine is started, disconnect the cables in the reverse order and keep the engine running for several minutes.

8

### NOTE



- On vehicles with anti-lock brake system, if the vehicle is put in motion without fully charging the battery, it might cause the loss of the smooth engine operation and the anti-lock brake warning lamp to illuminate. Refer to “Anti-lock brake system (ABS)” on page 6-69.

## Engine overheating

E00800604292

When the engine is overheating, the warning will be displayed in the instrument cluster as follows.

8-4 For emergencies

- The information screen in the multi information display will be interrupted and the engine coolant temperature warning display will appear. Also “” will blink. (Color liquid crystal display type)
- “” will blink. (Mono-color liquid crystal display type)

If this occurs, take the following corrective measures:

1. Stop the vehicle in a safe place.
2. Check whether steam is coming from the engine compartment.

[If steam does not come from the engine compartment]

With the engine still running, raise the bonnet to ventilate the engine compartment.

### NOTE

- For vehicles equipped with the Auto Stop & Go (AS&G) system, press the “Auto Stop & Go (AS&G) OFF” switch to deactivate the Auto Stop & Go (AS&G) system before stopping the vehicle. Refer to “To deactivate” on page 6-27.

[If steam is coming from the engine compartment]

Stop the engine, and when the steam stops, raise the bonnet to ventilate the engine compartment. Restart the engine.

### WARNING

- Do not open the bonnet while steam is coming from the engine compartment. It could cause steam or hot water to spurt out, causing burns. Hot water could spurt out even when there is no steam coming out, and some parts will be very hot. Be very careful when opening the bonnet.
- Be careful of hot steam, which could be blowing off the reserve tank cap.
- Do not attempt to remove the radiator cap while the engine is hot.

3. Confirm that the cooling fan (B) is turning.

[If the cooling fan is turning]

After the high coolant temperature warning has gone off, stop the engine.

[If the cooling fan is not turning]

Stop the engine immediately and contact an authorised MITSUBISHI MOTORS dealer for assistance.

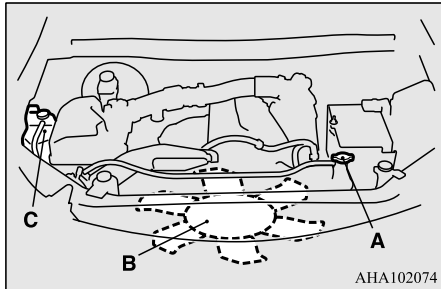

- A- Radiator cap
- B- Cooling fan
- C- Reserve tank

**⚠ WARNING**

- Be careful not to get your hands or clothes caught in the cooling fan.

4. Check the coolant level in the reserve tank (C).

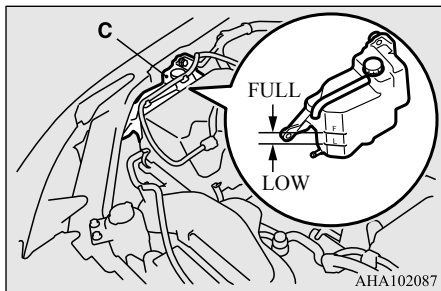

5. Add coolant to the radiator and/or reserve tank if necessary (refer to the “Maintenance” section).

**⚠ WARNING**

- Make sure that the engine has cooled down before removing the radiator cap (A), because hot steam or boiling water otherwise will gush from the filler port and may scald you.

**⚠ CAUTION**

- Do not add coolant while the engine is hot. Suddenly adding cold coolant could damage the engine. Wait for the engine to cool down, then add coolant a little at a time.

6. Examine the radiator hoses for coolant leakage and the drive belt for looseness or damage. If there is anything wrong with the cooling system or drive belt, have the problem corrected at an authorised MITSUBISHI MOTORS dealer.

### Bleeding the fuel system

E00800701511

The fuel system should be bled to remove air as described below if the fuel supply is exhausted during travel.

### Bleeding the fuel system

Pump the hand pump (A) at the top of the fuel filter until the hand pump becomes stiff. Then try again to start the engine. If the engine does not start, repeat the process above.

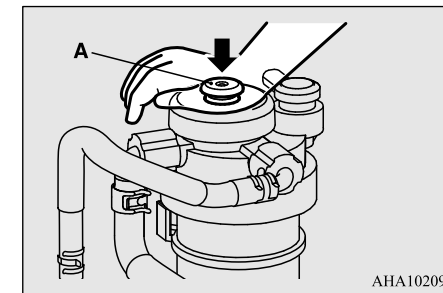

AHA102090

**⚠ CAUTION**

- Do not smoke or have any other open flame near the vehicle while bleeding the fuel system.
- Be sure to carefully clean away any spilt fuel which could ignite and cause a fire.

### Removal of water from the fuel filter

E00800801642

If the fuel filter indicator lamp in the instrument panel illuminates or the fuel filter indicator display on the information screen in the

## Tools, jack and jack handle

multi information display appears during driving, it indicates that water has accumulated in the fuel filter. If this occurs, remove the water as described below.

Indicator lamp (mono-color liquid crystal display)



Indicator display (color liquid crystal display)

8



1. Loosen the drain plug (A) of the fuel filter.

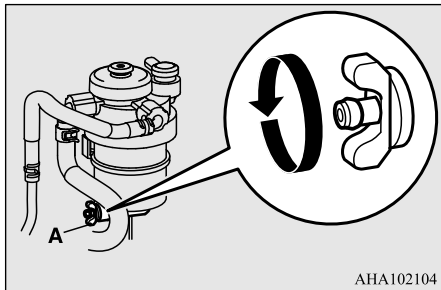

2. Operate the hand pump (B) slowly 6 or 7 times in order to force the water out through the drain plug (A).

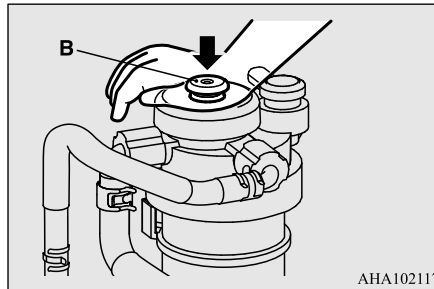

3. Tighten the drain plug (A) when water no longer comes out.
4. Bleed the air in the fuel system. (Refer to “Bleeding the fuel system” on page 8-5.)
5. [Vehicles equipped with the mono-color liquid crystal display]  
Check to be sure that the fuel filter indicator lamp illuminates when the ignition switch is turned to “ON” or the operation mode is put in ON, and that it goes off when the engine is started.  
[Vehicles equipped with the color liquid crystal display]  
Check to be sure that the fuel filter indicator display does not appear when the ignition switch is turned to “ON” or the operation mode is put in ON.

If in doubt, consult your nearest authorised MITSUBISHI MOTORS dealer.

### **CAUTION**

- Do not smoke or have any other open flame near the vehicle while bleeding the fuel system.
- Be sure to carefully clean away any water drained out because any fuel mixed with the water could ignite and cause a fire.

## Tools, jack and jack handle

E00800902608

### Storage

The storage location of the tools, jack and jack handle should be remembered in case of an emergency.

**Single cab**

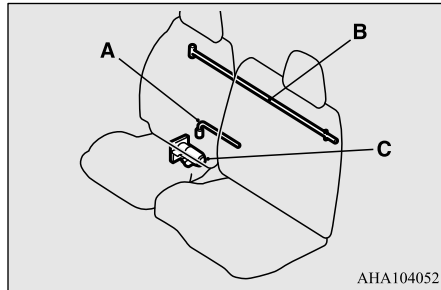

- A- Tool (wheel nut wrench)
- B- Jack handle
- C- Jack

AHA104052

**Club cab**

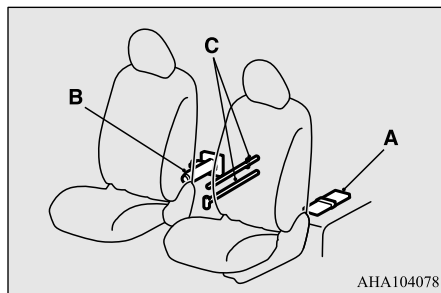

- A- Tools
- B- Jack

AHA104078

C- Jack handle

**Double cab**

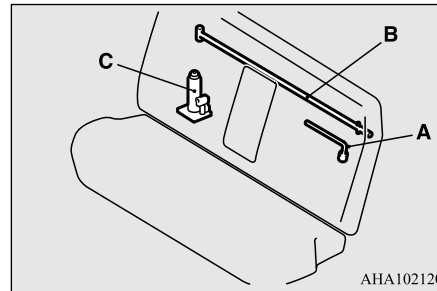

- A- Tool (wheel nut wrench)
- B- Jack handle
- C- Jack

AHA102120

**Tools**

E00801902054

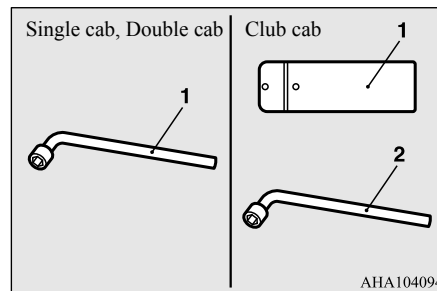

AHA104094

**Single cab, Double cab**

- 1- Wheel nut wrench

**Club cab**

- 1- Tool bag
- 2- Wheel nut wrench

**Removing and storing the tools, jack and jack handle**

E00802301540

**8**

**Single cab**

The tools, jack, and jack handle are located behind the seat.

1. Tip forward the seatback.  
(Refer to "Passenger's seat (Single cab)" on page 4-3.)
2. Remove the wheel nut wrench (A) from the holder (B), and take out the wrench.

## Tools, jack and jack handle

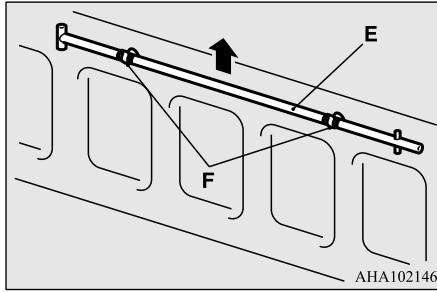
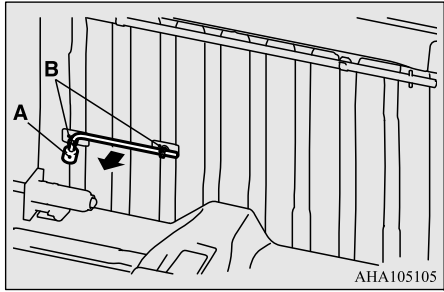

8

3. Remove the securing nut (C), and then take out the jack (D).

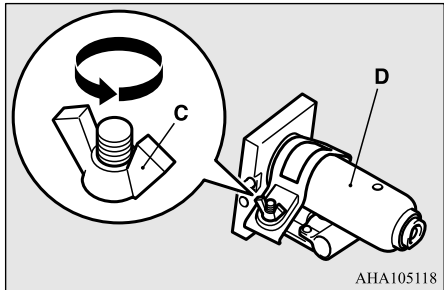

4. Remove the jack handle (E) from the holder (F), and take out the handle.

5. Reverse the removing procedure when storing the tools, jack and jack handle.

### NOTE

- When stowing the jack handle, align the black-marked part (G) of the jack handle with the holder (H).

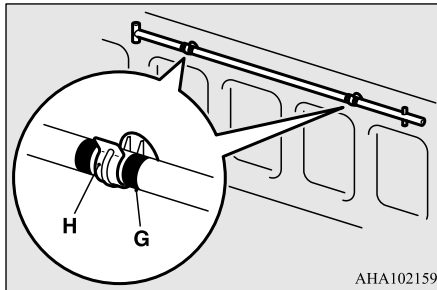

## Club cab

The tools are stored under the floor behind the passenger's seat.

The jack, and jack handle are stored under the floor behind the driver's seat.

1. Open the rear door. Refer to "To open or close the rear door (Club cab)" on page 3-17.
2. Open the lid.

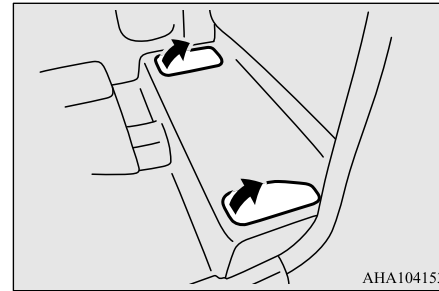

3. Remove the securing band (A), and then take out the tools (B) on the left-hand side.

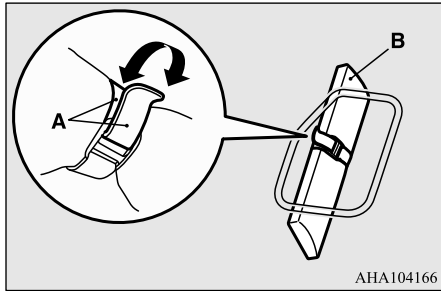

4. Remove the securing nut (C), and then take out the jack (D) on the right-hand side.

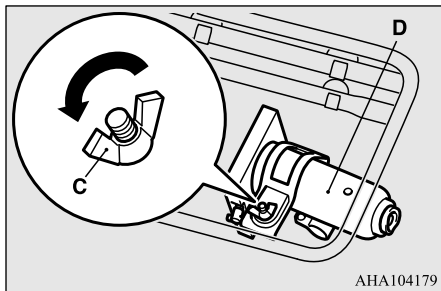

5. Remove the jack handle (E) from the holder (F), and then take out the jack handle on the right-hand side.

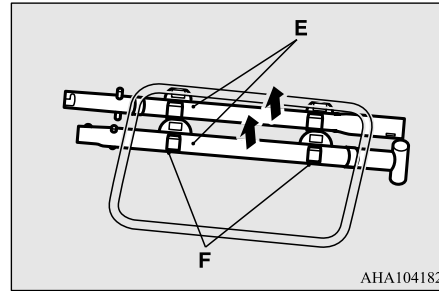

6. Reverse the removing procedure when storing the tools, jack and jack handle.

**NOTE**

- When stowing the jack handle, align the coloured marking on the jack handle with that on the holder, and fit the jack in the holder.

**Double cab**

The tools, jack, and jack handle are located behind the rear seat.

1. Tip forward the seatback of the rear seat. (Refer to “Folding the seatback forward” on page 4-3.)
2. Remove the wheel nut wrench (A) from the holder (B), and take out the wrench.

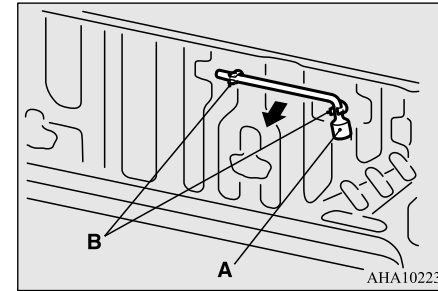

3. Remove the securing nut (C), and then take out the jack (D).

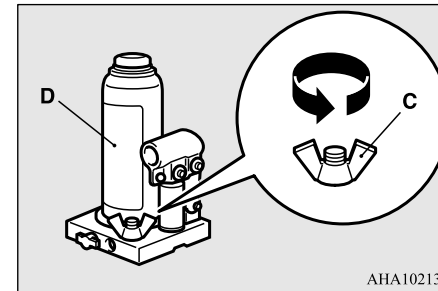

4. Remove the jack handle (E) from the holder (F), and take out the handle.

## How to change a tyre

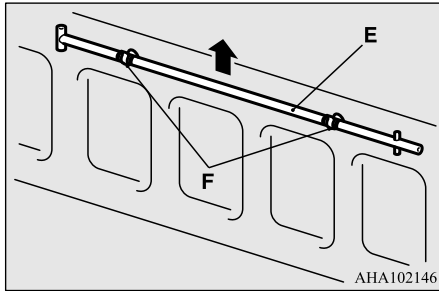

5. Reverse the removing procedure when storing the tools, jack and jack handle.

8

### NOTE

- When stowing the jack handle, align the black-marked part (G) of the jack handle with the holder (F).

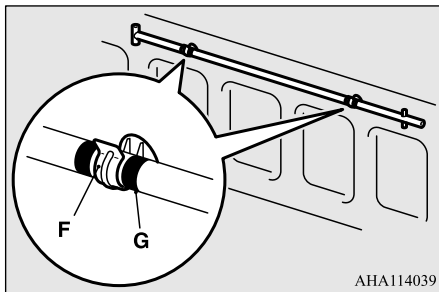

## To use the jack handle (Club cab)

E00802401189

1. While pressing the snap pin (A) on the handle that has a black marking, withdraw and remove the inner handle (B).

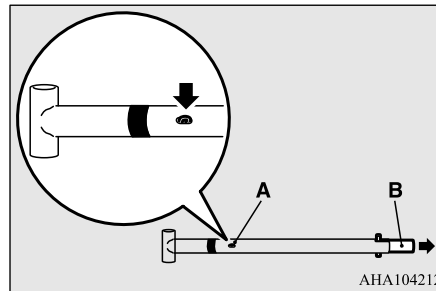

2. Reverse the inner handle (B) then, while pressing the snap pin (C), insert it into the outer handle (D) until it is locked by snap pin as illustrated.

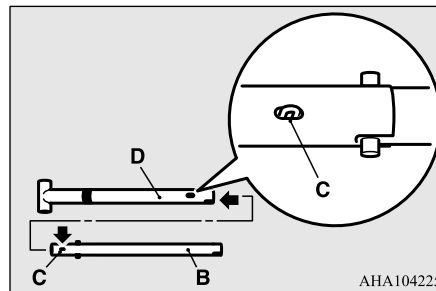

3. While pressing the snap pin (F) on the assembled handle (E), insert the white-marked handle (G) until it is locked by snap pin as illustrated.

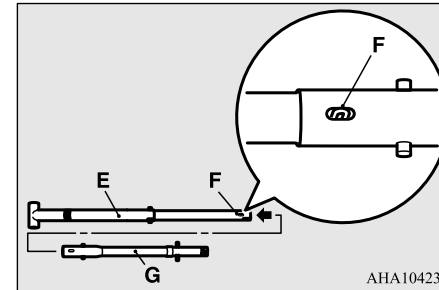

## How to change a tyre

E00801204051

Before changing a tyre, first stop your vehicle in a safe, flat location.

1. Park the vehicle on level and stable ground, free of loose pebbles, etc.
2. Set the parking brake firmly.
3. On vehicles with manual transmission, turn the ignition switch to the "LOCK" position or put the operation mode in OFF, and move the gearshift lever to the "R" (Reverse) position.

On vehicles with automatic transmission, move the selector lever to the “P” (PARK) position, and turn the ignition switch to the “LOCK” position or put the operation mode in OFF.

4. Turn on the hazard flashers and set up a warning triangle, flashing signal lamp, etc., at an adequate distance from the vehicle, and have all your passengers leave the vehicle.
5. To prevent the vehicle from rolling when jacking up the vehicle, place chocks or blocks (A) at the tyre that is diagonally opposite from the tyre (B) you are changing.

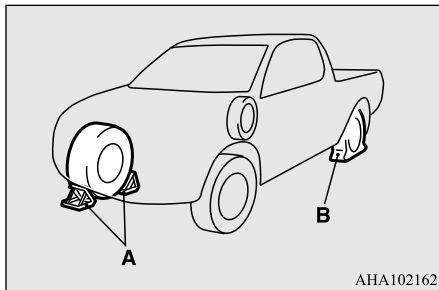

AHA102162

### WARNING

- Be sure to apply chocks or blocks to the correct tyre when jacking up the vehicle. If the vehicle moves while jacked up, the jack could slip out of position, leading to an accident.

### NOTE

- The chocks shown in the illustration do not come with your vehicle. It is recommended that you keep ones in the vehicle for use if needed.
- If chocks are not available, use stones or any other objects that are large enough to hold the wheel in position.

6. Get the jack, jack handle and wheel nut wrench ready.  
Refer to “Tools, jack and jack handle” on page 8-6.

### Spare wheel information

E00803601801

The spare wheel is stored under the floor of the cargo bed.

Check the air pressure of the spare tyre frequently and make sure it is ready for emergency use at any time.

Maintaining the spare wheel at the highest specified air pressure will ensure that it can always be used under any conditions (city/high-speed driving, varying load weight, etc.).

### CAUTION

- The pressure should be periodically checked and maintained at the specified pressure while the tyre is stowed.  
Driving with an insufficient tyre pressure can lead to an accident. If you have no choice but to drive with an insufficient tyre pressure, keep your speed down and inflate the tyre to the correct pressure as soon as possible. (Refer to “Tyre inflation pressures” on page 10-12.)

### To remove the spare wheel

E00803501901

8

#### Type 1

1. Set the jack handle. (Club cab)  
(Refer to “To use the jack handle (Club cab)” on page 8-10.)
2. Insert the jack handle (A) in the hole (B) below the rear gate.

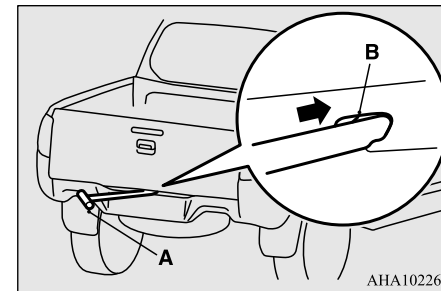

AHA102263



## How to change a tyre

3. Securely insert the pin (C) on the jack handle into the holder (D) of the spare wheel carrier.

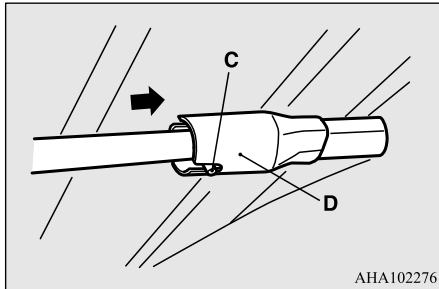

8

4. Insert the wheel nut wrench (E) through the end of the jack handle hole (F), and then turn it anticlockwise to lower the spare wheel completely to the ground and to slack the chain.

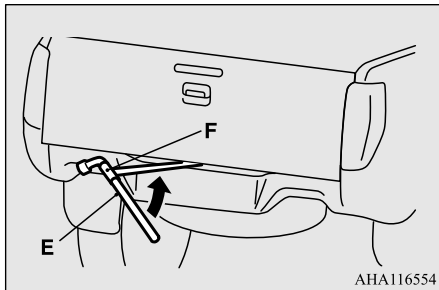

### CAUTION

- When removing the spare wheel, please observe the followings. If you do not follow them, it could result in break the spare wheel carrier.
- Do not use the power tool. Use the wheel nut wrench stowed on the vehicle.
- Do not apply a force of 400 N or more at the end of the wheel nut wrench.

5. Remove the hanger disc (G) from the spare wheel.

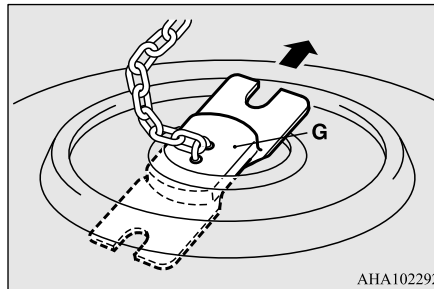

### NOTE

- Put the spare wheel under the vehicle body near the flat tyre. This makes it safer if the jack slips out of position.

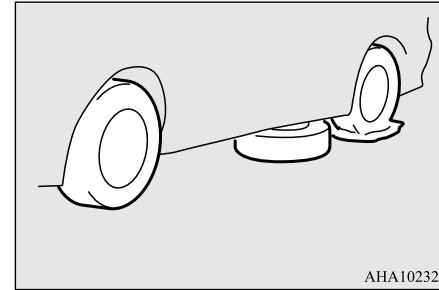

Type 2

### CAUTION

- When removing the spare wheel, put on gloves. Removing the spare wheel with your bare hands may cause injury to the fingers.

1. Remove the spare tyre cap (A) in the cargo area.

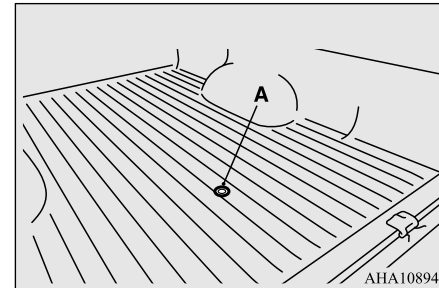

2. Turn the securing bolt (B) anticlockwise with the wheel nut wrench to lower the spare wheel completely to the ground and to slack the chain.

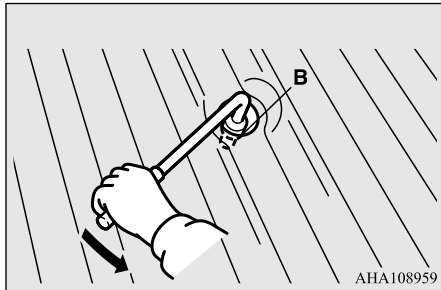

AHA108959

**CAUTION**

- When removing the spare wheel, please observe the followings.  
If you do not follow them, it could result in break the spare wheel carrier.
- Do not use the power tool. Use the wheel nut wrench stowed on the vehicle.
- Do not apply a force of 200 N or more at the end of the wheel nut wrench.

3. Remove the hanger disc (C) from the spare wheel.

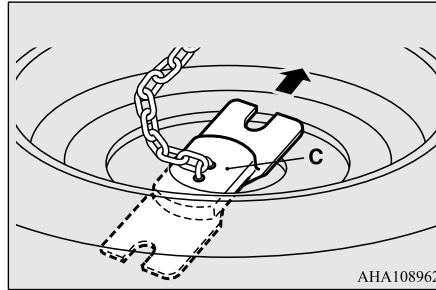

AHA108962

**NOTE**

- When the tire entire surface has been grounded, the hanger disc cannot remove from the spare wheel. Remove the hanger disc after lifting and tilting the tire.
- Put the spare wheel under the vehicle body near the flat tyre. This makes it safer if the jack slips out of position.

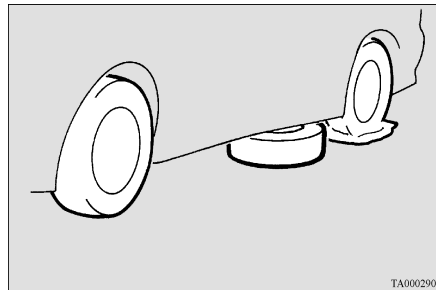

TA0002900

**To change a tyre**

E00803202729

1. Loosen the wheel nuts a quarter turn with the wheel nut wrench. Do not remove the wheel nuts yet.

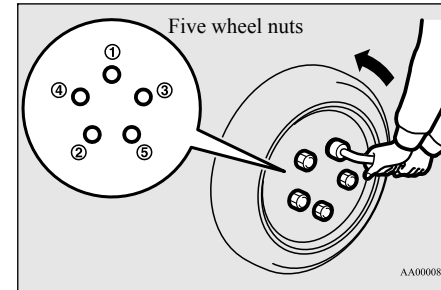

AA0000877

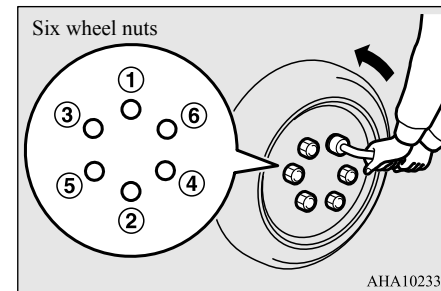

AHA102335

2. Place the jack under one of the jacking points shown in the illustration. Use the jacking point closest to the tyre you wish to change.

## How to change a tyre

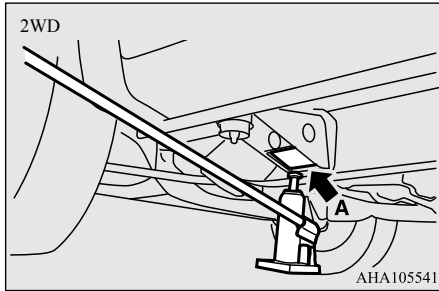

A- Front jacking point (vehicles for 2WD)

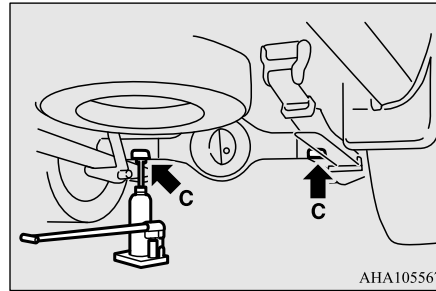

C- Rear jacking point

8

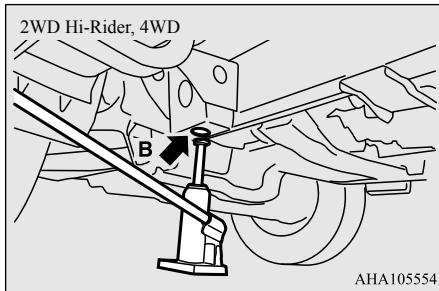

B- Front jacking point (vehicles for 2WD Hi-Rider or 4WD)

### ⚠ WARNING

- Set the jack only at the positions shown here. If the jack is set at a wrong position, it could dent your vehicle or the jack might fall over and cause personal injury.
- Do not use the jack on a tilted or soft surface. Otherwise, the jack might slip and cause personal injury. Always use the jack on a flat, hard surface. Before setting the jack, make sure there are no sand or pebbles under the jack base.

### NOTE

- When jacking up the rear of the vehicle, turn the tip of the jack so that the grooved portion (D) properly meets the designated point.

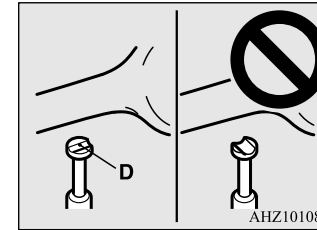

- Using the jack handle, turn the release valve (E) clockwise until it stops.

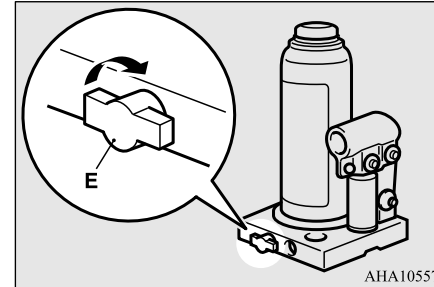

- Insert the jack handle in the bracket of the jack and hook the notch (F) on the jack handle end to the claw (G) of the bracket.

5. Move the jack handle up and down to raise the ram until just before the jack contacts the jacking point of the vehicle. Ensure that the jack will properly contact the vehicle jacking point. Move the jack handle up and down to raise the vehicle.

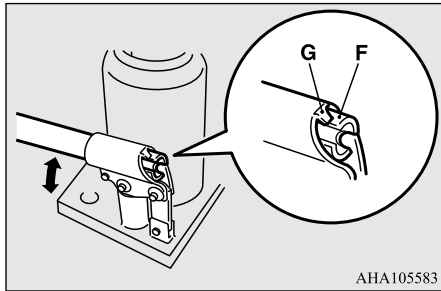

**NOTE**

- This jack is a 2 stage expansion type.

**WARNING**

- Stop jacking up the vehicle as soon as the tyre is raised off the ground. It is dangerous to raise the vehicle any higher.
- Do not get under your vehicle while using the jack.
- Do not bump the raised vehicle or leave it sitting on the jack for a long time. Both are very dangerous.

**WARNING**

- Do not use a jack except the one that came with your vehicle.
- The jack should not be used for any purpose other than to change a tyre.
- No one should be in your vehicle when using the jack.
- Do not start or run the engine while your vehicle is on the jack.
- Do not turn the raised wheel. The tyres still on the ground could turn and make your vehicle fall off the jack.

6. Remove the wheel nuts with the wheel nut wrench, then take the wheel off.

**CAUTION**

- Handle the wheel carefully when changing the tyre, to avoid scratching the wheel surface.

7. Clean out any mud, etc. on the hub surface (H), hub bolts (I) or in the installation holes (J) in the wheel, and then mount the spare wheel.

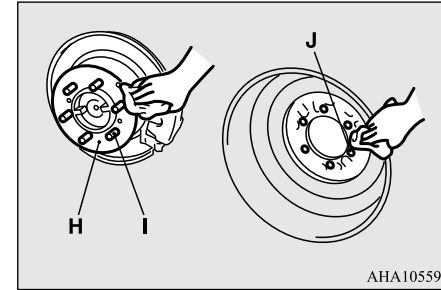

**WARNING**

- Mount the spare wheel with the valve stem (K) facing outboard. If you cannot see the valve stem (K), you have installed the wheel backwards. Operating the vehicle with the spare wheel installed backwards can cause vehicle damage and result in an accident.

8

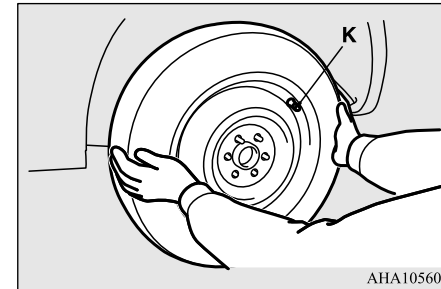

## How to change a tyre

8. Turn the wheel nuts clockwise by hand to initially tighten them.

### [Type 1: On vehicles with steel wheels]

Temporarily tighten the wheel nuts by hand until the tapered parts of the wheel nuts make light contact with the seats of the wheel holes and the wheel is not loose.

### [Type 2: On vehicles with aluminium wheels]

Temporarily tighten the wheel nuts by hand until the flange parts of the wheel nuts make light contact with the wheel and the wheel is not loose.

8

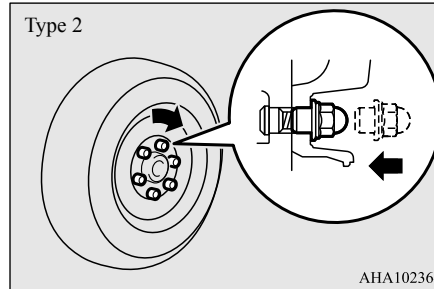
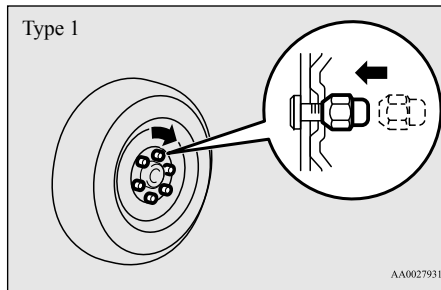

### ⚠ CAUTION

- Never apply oil to either the wheel bolts or the nuts or they will tighten too much.

### 📖 NOTE

- If all 4 aluminium wheels are changed to steel wheels. e. g. when fitting winter tyres, use tapered nuts.

9. Put the notch (L) provided on the jack handle end on the valve (M) of the jack. Using the jack handle, turn the release valve anticlockwise slowly to lower the vehicle until the tyre touches the ground.

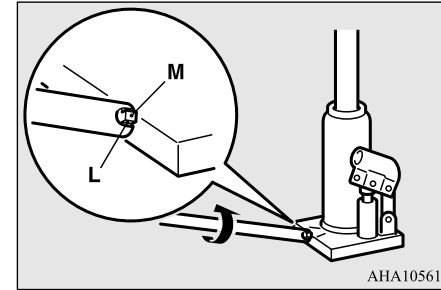

### ⚠ WARNING

- Be sure to open the release valve slowly. If it is opened quickly, the vehicle will drop abruptly and the jack may come out of position, causing a serious accident.

10. Tighten the nuts crisscross in 2 or 3 steps until each nut has been tightened securely.

Tightening torque

Steel wheel: 137 to 157 N•m

Aluminium wheel: 118 to 137 N•m

(Achieved by applying a force at the end of the wheel nut wrench supplied with the vehicle.

Steel wheel: 510 to 580 N

Aluminium wheel: 440 to 500 N)

## How to change a tyre

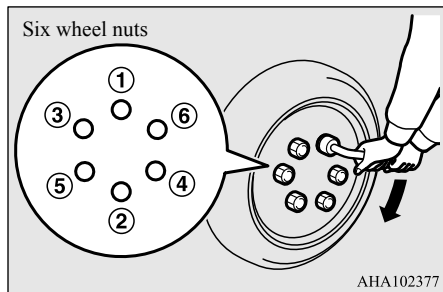
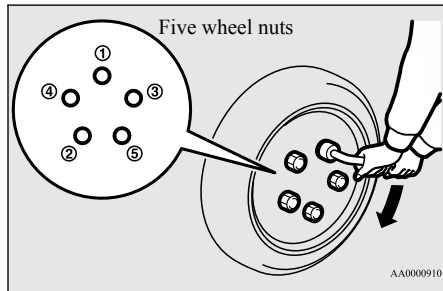

### ⚠ CAUTION

- Never use your foot or a pipe extension for extra force in the wheel nut wrench. If you do so, you will tighten the nut too much.

11. Lower the jack all the way and remove it.

### ⚠ CAUTION

- If the release valve is loosened too much (2 or more turns) in the anticlockwise direction, the jack's oil will leak and the jack cannot be used.
- Close the release valve slowly when lowering the vehicle, or the valve may be damaged.

### 📖 NOTE

- Occasionally when the vehicle is jacked up, the grooved portion of the designated point will not come off. When this happens, rock the vehicle to lower the ram.
- If the jack is difficult to remove by hand, insert the jack handle (N) into the bracket (O). Then using the handle, remove the jack.

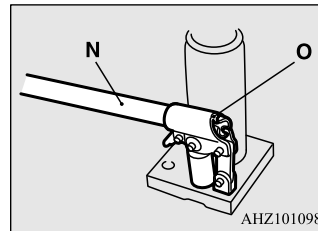

12. Press the piston down all the way, and turn the release valve clockwise as far as possible.

13. Check your tyre inflation pressure. The correct pressures are shown on the door label. See the illustration.

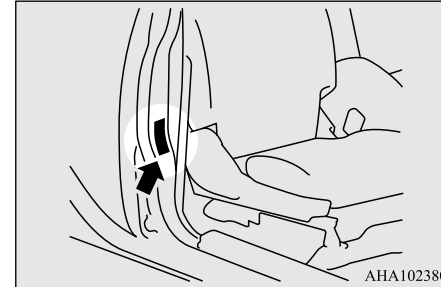

8

### ⚠ CAUTION

- The tyre pressure should be periodically checked and maintained at the specified pressure while the tyre is stowed.
- After changing the tyre and driving the vehicle about 1,000 km, retighten the wheel nuts to make sure that they have not come loose.
- If the steering wheel vibrates when driving after changing the tyre, have the tyre checked for balance at your nearest authorised MITSUBISHI MOTORS dealer.
- Do not mix one type of tyre with another or use a different size from the one listed. This would cause early wear and poor handling.

## How to change a tyre

### To store the spare wheel

E00803701785

#### Type 1

1. Install the hanger disc (A) in the wheel disc hole.

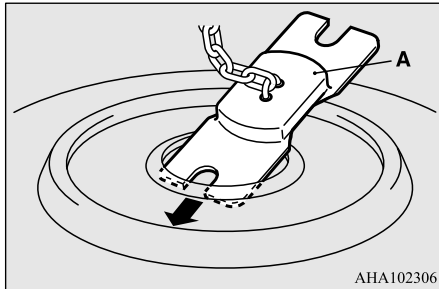

2. Turn the wheel nut wrench (B) clockwise to wind up the chain.

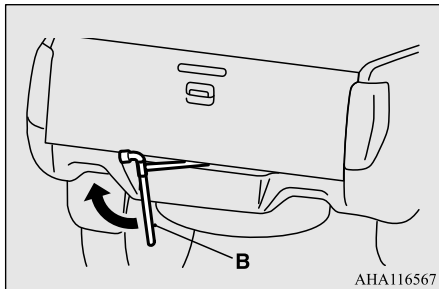

#### NOTE

- Confirm that the hanger disc is securely fitted in the wheel disc hole when the wheel is just lifted off the ground.

3. After winding up the spare wheel sufficiently, make sure it is not loose (the tightening torque should be approximately 40 N•m (achieved by applying a force of 200 N at the end of the wheel nut wrench.)) then withdraw the jack handle, taking care not to turn it in the reverse direction.

#### CAUTION

- The spare wheel should always be securely in position.  
If a flat tyre is changed, put the flat tyre in the spare wheel mounting position with the wheel outer surface upward, and use the wheel nut wrench to secure it firmly.
- When installing the spare wheel, please observe the followings. If you do not follow them, it could result in break the spare wheel carrier.
  - Do not use the power tool.  
Use the wheel nut wrench stowed on the vehicle.
  - Do not apply a force of 400 N or more at the end of the wheel nut wrench.

4. Have your damaged tyre repaired as soon as possible.

#### Type 2

1. Install the hanger disc (A) in wheel disc hole.

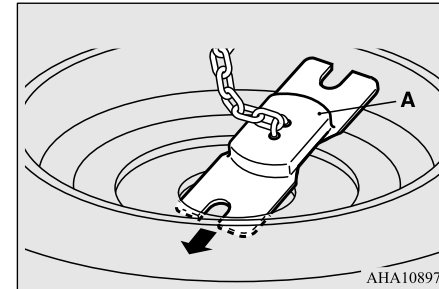

#### NOTE

- When the tire entire surface has been grounded, the hanger disc cannot install from the wheel. Install the hanger disc after lifting and tilting the tire.

2. Turn the securing bolt (B) clockwise with the wheel nut wrench to wind up the chain.

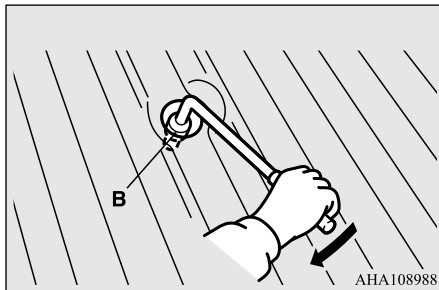

AHA108988

**CAUTION**

- When installing the spare wheel, please observe the followings. If you do not follow them, it could result in break the spare wheel carrier.
- Do not use the power tool.  
Use the wheel nut wrench stowed on the vehicle.
- Do not apply a force of 200 N or more at the end of the wheel nut wrench.

**NOTE**

- Confirm that the hanger disc is securely fitted in the wheel disc hole when the wheel is just lifted off the ground.

**NOTE**

- Overtightening the securing bolt can damage the gear, resulting in the gear not winding up the chain.

3. After winding up the spare wheel sufficiently, make sure it is not loose (the tightening torque should be approximately 22 N•m (achieved by applying a force of 100 N at the end of the wheel nut wrench)).

4. Replace the spare tyre cap (C).

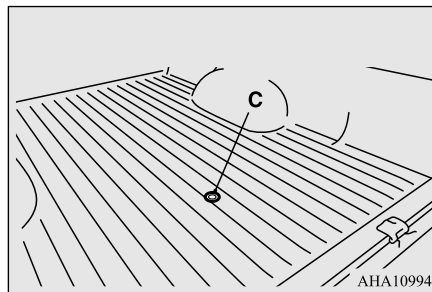

AHA109943

**CAUTION**

- The spare wheel should always be secured in position.  
If a flat tyre is changed, put the flat tyre in the spare wheel mounting position with the wheel outer surface downward, and use the wheel nut wrench to secure it firmly.

**To store the tools, jack and jack handle**

E00803801193

Reverse the removing procedure when storing the jack, jack handle and wheel nut wrench.  
Refer to “Tools, jack and jack handle” on page 8-6.

**Towing**

E00801506553

**If your vehicle needs to be towed**

If towing is necessary, we recommend you to have it done by your authorised MITSUBISHI MOTORS dealer or a commercial tow truck service.  
In the following cases, transport the vehicle using a tow truck.

- The engine runs but the vehicle does not move, or an abnormal noise is produced.
- Inspection of the vehicle’s underside reveals that oil or some other fluid is leaking.

If a wheel gets stuck in a ditch, do not try to tow the vehicle. Please contact your author-



## Towing

ised MITSUBISHI MOTORS dealer or a commercial tow truck service for assistance.

Only when you cannot receive a towing service from an authorised MITSUBISHI MOTORS dealer or commercial tow truck service, tow your vehicle carefully in accordance with the instructions given in “Emergency towing” in this part.

The regulations concerning towing may differ from country to country. It is recommended that you obey the regulations of the area where you are driving your vehicle.

8

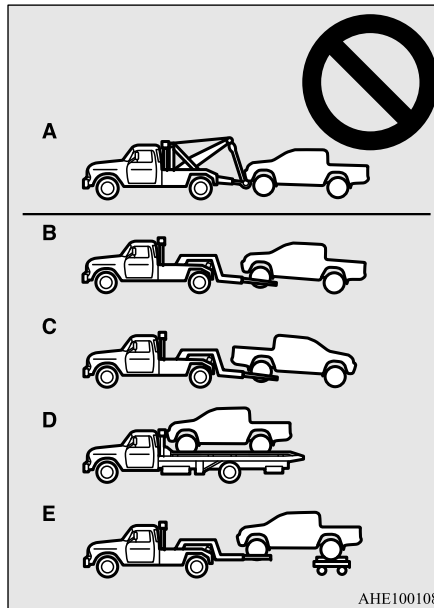

### Towing the vehicle by a tow truck

#### ⚠ CAUTION

- This vehicle must not be towed by a tow truck using sling lift type equipment (Type A) as illustrated. Using a sling lift will damage the bumper and front end.

#### ⚠ CAUTION

- On 4WD vehicles, transport the vehicle with the driving wheels on a carriage (Type D or E) as illustrated. Never try to tow with the front or rear wheels on the ground (Type B or C) as illustrated. This could result in the driving system damage or vehicle may jump at the carriage.
- If your vehicle is equipped with the Active Stability & Traction Control system (ASTC), if the vehicle is towed with the ignition switch in the “ON” position or the operation mode in ON and only the front wheels or only the rear wheels raised off the ground, the active traction control system may operate, resulting in an accident.
- On 2WD vehicles, if the transmission is malfunctioning or damaged, transport the vehicle with the driving wheels on a carriage (Type C, D or E) as illustrated.
- If you tow the vehicles with automatic transmission with the driving wheels on the ground (Type B) as illustrated, make sure that the towing speed and distance given below are never exceeded, causing damage to the transmission.

Towing speed: 30 km/h  
Towing distance: 80 km

For the towing speed and the towing distance, follow the local driving laws and regulations.

**⚠ CAUTION**

- On vehicles with manual transmission, do not tow the vehicle with the rear wheels on the ground (Type B) as illustrated.

**Towing with front wheels off the ground (Type B)**

On vehicles with automatic transmission, place the selector lever in the “N” (NEUTRAL) position. Release the parking brake.

**⚠ CAUTION**

- Never tow an automatic transmission vehicle with the front wheels up (and the rear wheels on the ground) (Type B) when the A/T fluid level is low. This may cause serious and expensive damage to the transmission.

**Towing with rear wheels off the ground (Type C)**

Place the gearshift lever in the “N” (Neutral) position (manual transmission) or the selector lever in the “N” (NEUTRAL) position (automatic transmission). Turn the ignition switch to the “ACC” position or put the operation mode in ACC and secure the steering wheel in a straight-ahead position with a rope or tie-

down strap. Never place the ignition switch in the “LOCK” position or put the operation mode in OFF when towing.

**Emergency towing**

If towing service is not available in an emergency, your vehicle may be temporarily towed by a rope secured to the towing hook. If your vehicle is to be towed by another vehicle or if your vehicle tows another vehicle, pay careful attention to the following points.

**If your vehicle is to be towed by another vehicle**

1. The front towing hook (A) is located as shown in the illustration. Secure the tow rope to the front towing hook.

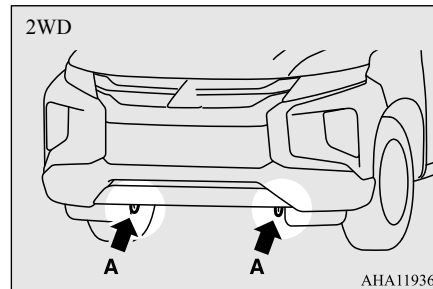

2WD Hi-Rider, 4WD

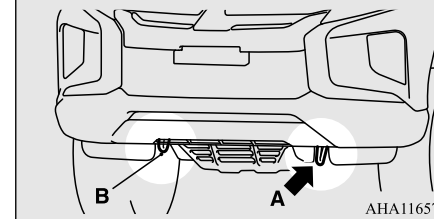

**⚠ CAUTION**

- Using any part other than the designated towing hook (A) could result in damage to vehicle body.
- Do not use the tie-down hook (B) for towing. This hook is provided only for the purpose of transporting the vehicle itself.

**📖 NOTE**

- Using a wire rope or metal chain can result in damage to the vehicle body. It is best to use a non-metallic rope. If you use a wire rope or metal chain, wrap it with cloth at any point where it touches the vehicle body.
- Use care that the tow rope is kept as horizontal as possible. An angled tow rope can damage the vehicle body.
- Secure the tow rope to the same side towing hook, to keep the tow rope as straight as possible.

## Towing

### 2. Keep the engine running.

If the engine is not running, perform the following operation to unlock the steering wheel.

[Except for vehicles with the keyless operation system]

On vehicles with manual transmission, turn the ignition switch to the “ACC” or “ON” position.

On vehicles with automatic transmission, turn the ignition switch to the “ON” position.

[For vehicles with the keyless operation system]

On vehicles with manual transmission, put the operation mode in ACC or ON.

On vehicles with automatic transmission, put the operation mode in ON.

8

### NOTE

- For vehicles equipped with the Auto Stop & Go (AS&G) system, press the “Auto Stop & Go (AS&G) OFF” switch to deactivate the Auto Stop & Go (AS&G) system before stopping the vehicle. Refer to “To deactivate” on page 6-27.

### WARNING

- When the engine is not running, the brake booster and power steering pump do not operate. This means higher brake depression force and higher steering effort are required. Therefore, vehicle operation is very difficult.

### CAUTION

- Do not leave the ignition switch in the “LOCK” position or the operation mode in OFF. The steering wheel will lock, causing loss of control.
- For vehicle equipped with the Forward Collision Mitigation system (FCM), stop the system to prevent an unexpected accident or unexpected operation during towing. Refer to “Forward Collision Mitigation system (FCM)” on page 6-80.

3. Place the gearshift lever in the “N” (Neutral) position (manual transmission) or the selector lever in the “N” (NEUTRAL) position (automatic transmission).

4. On 4WD vehicles, set the drive mode-selector to “2H” position.

5. Turn on the hazard warning lamps if required by law. (Follow the local driving laws and regulations.)

6. During towing make sure that close contact is maintained between the drivers of both vehicles, and that the vehicles travel at low speed.

### WARNING

- Avoid sudden braking, acceleration and steering wheel movements; such driving operation could cause damage to the towing hook or towing rope. People in the vicinity could be injured as a result.
- When going down a long slope, the brakes may overheat, reducing effectiveness. Have your vehicle transport by a tow truck.

### CAUTION

- The person in the vehicle being towed must pay attention to the brake lamps of the towing vehicle and make sure the rope never becomes slack.

**⚠ CAUTION**

- When the vehicle with an automatic transmission is to be towed by another vehicle with the all wheels on the ground, make sure that the towing speed and distance given below are never exceeded, avoiding damage to the transmission.

Towing speed: 30 km/h  
Towing distance: 80 km

For the towing speed and the towing distance, follow the local driving laws and regulations.

**Operation under adverse driving conditions**

E00801704056

**On a flooded road**

- Avoid flooded roads. In the event driving flooded roads, doing so may cause the following serious damage to the vehicle.
  - Engine stalling
  - Short in electrical components
  - Engine damage caused by water immersion

After driving flooded roads, be sure to have an inspection at an authorised MITSUBISHI MOTORS dealer and take the necessary measures or repair.

**On a wet road**

- When driving in rain or on a road with many puddles a layer of water may form between the tyres and the road surface. This reduces a tyre's frictional resistance on the road, resulting in loss of steering stability and braking capability.

To cope with this, observe the following items:

- Drive your vehicle at a slow speed.
- Do not drive on worn tyres.
- Always maintain the specified tyre inflation pressures.

**On a snow-covered or frozen road**

- When driving on a snow-covered or frozen road, it is recommended that you use snow tyres or snow traction device (tyre chains).

Refer to the “Snow tyres” and “Snow traction device (tyre chains)” sections.

- Avoid high-speed operation, sudden acceleration, abrupt brake application and sharp cornering.
- Depressing the brake pedal during travel on snowy or icy roads may cause tyre slippage and skidding. When traction between the tyres and the road is reduced the wheels may skid and the vehicle cannot readily be brought to a stop by conventional braking techniques. Braking will differ, depending upon whether you have anti-lock brake system (ABS). If you do have ABS, brake by pressing the brake pedal hard, and keeping it pressed. If you do not have ABS, pump the brake pedal with short rapid jabs, each time fully applying and fully releasing for greatest effect.
- Allow extra distance between your vehicle and the vehicle in front of you, and avoid sudden braking.
- Accumulation of ice on the braking system can cause the wheels to lock. Pull away from a standstill slowly after confirming safety around the vehicle.

## Operation under adverse driving conditions

---

### CAUTION

- Do not press the accelerator pedal rapidly. If the wheels break free of the ice, the vehicle could suddenly start moving and possibly cause an accident.

### **On a bumpy or rutted road**

Drive as slow as possible when driving on bumpy or rutted roads.

**8**

### CAUTION

- The impact on tyres and/or wheels when driving on a bumpy or rutted road can damage the tyre and/or wheel.

*Vehicle care*

Vehicle care precautions .....9-2  
Cleaning the interior of your vehicle .....9-2  
Cleaning the exterior of your vehicle .....9-3

## Vehicle care precautions

### Vehicle care precautions

E00900102005

In order to maintain the value of your vehicle, it is necessary to perform regular maintenance using the proper procedures.

Always maintain your vehicle in compliance with any environmental pollution control regulations.

Carefully select the materials used for washing, etc., to be sure that they do not contain corrosives; if in doubt, we recommend you to consult a specialist for the selection of these materials.

9

#### CAUTION

- Cleaning products can be dangerous. Always follow the instructions of the cleaning product supplier.
- To avoid damage, never use the following to clean your vehicle.
  - Petrol
  - Paint Thinner
  - Benzine
  - Kerosene
  - Turpentine
  - Naphtha
  - Lacquer Thinner
  - Carbon Tetrachloride
  - Nail Polish Remover
  - Acetone

### Cleaning the interior of your vehicle

E00900201719

After cleaning the interior of your vehicle with water, cleaner or similar, wipe and dry in a shady, well-ventilated area.

#### NOTE

- If your vehicle has the demister heater element of the rear window, to clean the inside of the rear window, always use a soft cloth and wipe the window glass along the demister heater element so as not to cause damage.

#### CAUTION

- Do not use organic substances (solvents, benzine, kerosene, alcohol, petrol, etc.) or alkaline or acidic solutions. These chemicals can cause discolouring, staining or cracking of the surface. If you use cleaners or polishing agents, make sure their ingredients do not include the substances mentioned above.

### Plastic, vinyl leather, fabric and flocked parts

E00900301563

1. Lightly wipe these off with a soft cloth soaked in a mild soap and water solution.
2. Dip cloth in fresh water and wring it out well. Using this cloth, wipe off the detergent thoroughly.

#### NOTE

- Do not use cleaners, conditioners, and protectants containing silicones or wax. Such products can cause discolouring and, when applied to the instrument panels or other parts, may cause reflections on the windscreen and obscure vision. Also, if such products get on the switches of the electrical accessories, it may lead to failure of these accessories.
- Do not use synthetic fiber or dry cloth. They can cause discolouring or damaging the surface.
- Do not place a deodorizer on the instrument panel or near lamps and instruments. The ingredients for deodorizer can cause discolouring or cracking.

### Upholstery

E00900500207

1. To maintain the value of your new vehicle, handle the upholstery carefully and keep the interior clean.

Use a vacuum cleaner and brush to clean the seats. If stained, vinyl and synthetic leather should be cleaned with an appropriate cleaner. Cloth fabrics can be cleaned with either upholstery cleaner or a mild soap and water solution.

2. Clean the carpeting with a vacuum cleaner and remove any stains with carpet cleaner. Oil and grease can be removed by lightly dabbing with a clean colourfast cloth and stain remover.

### Genuine leather\*

E00900601960

1. To clean, lightly wipe the leather with a soft cloth soaked in a mild soap and water solution.
2. Dip cloth in fresh water and wring it out well. Using this cloth, wipe off the detergent thoroughly.
3. Apply leather protecting agent to the genuine leather surface.

#### NOTE

- If genuine leather is wet with water or is washed in water, wipe off water as quickly as possible with a dry, soft cloth. If left damp, mildew may grow.
- Organic solvents such as benzine, kerosene, alcohol and petrol, acid or alkaline solvents may discolour the genuine leather surface. Be sure to use neutral detergents.

#### NOTE

- Remove dirty patches or oil substances quickly as they can stain genuine leather.
- The genuine leather surface may harden and shrink if it is exposed to direct rays of the sun for long hours. When your vehicle is parked, place it in the shade as much as possible.
- When the temperature of the vehicle interior rises in summer, vinyl products left on the genuine leather seat may deteriorate and stick to the seat.

### Cleaning the exterior of your vehicle

E00900700108

If the following is left on your vehicle, it may cause corrosion, discolouration and stains, wash the vehicle as soon as possible.

- Seawater, road deicing products.
- Soot and dust, iron powder from factories, chemical substance (acids, alkalis, coal-tar, etc.).
- Droppings from birds, carcasses of insects, tree sap, etc.

#### Washing

E00900904241

Chemicals contained in the dirt and dust picked up from the road surface can damage

### Cleaning the exterior of your vehicle

the paint coat and body of your vehicle if left in prolonged contact.

Frequent washing and waxing is the best way to protect your vehicle from this damage. This will also be effective in protecting it from environmental elements such as rain, snow, salt air, etc.

Using an ample amount of clean water and a car washing brush or sponge, wash the vehicle from top to bottom.

Use a mild car washing soap if necessary. Rinse thoroughly and wipe dry with a soft cloth. After washing the vehicle, carefully clean the joints and flanges of the doors, bonnet and other sections where dirt is likely to remain.

#### CAUTION

- When washing the under side of your vehicle or wheel, be careful not to injure your hands.
- If your vehicle has rain sensor wipers, place the wiper switch lever in the "OFF" position to deactivate the rain sensor before washing the vehicle. Otherwise, the wipers will operate in the presence of water spray on the windscreen and may get damaged as a result.
- Refrain from excessively using a car wash as its brushes may scratch the paint surface, causing it to lose its gloss. Scratches will be especially visible on darker coloured vehicles.



## Cleaning the exterior of your vehicle

9

### CAUTION

- Never spray or splash water on the electrical components in the engine compartment. Doing so could have an adverse effect on the engine startability. Exercise caution also when washing the underbody; be careful not to spray water into the engine compartment.
- Some types of hot water washing equipment apply high pressure and heat to the vehicle. They may cause heat distortion and damage to the vehicle resin parts and may result in flooding of the vehicle interior. Therefore;
  - Maintain a distance of approx. 70 cm or more between the vehicle body and the washing nozzle.
  - When washing around the door glass, hold the nozzle at a distance of more than 70 cm and at right angles to the glass surface.
- After washing the vehicle, drive the vehicle slowly while lightly depressing the brake pedal several times in order to dry out the brakes. Leaving the brakes wet could result in reduced braking performance. Also, there is a possibility that they could freeze up or become inoperative due to rust, rendering the vehicle unable to move.
- Using an automatic car wash, pay attention to the following items, referring to the operation manual or consulting a car wash operator. If the following procedure is not followed, it could result in damage to your vehicle.

### CAUTION

- The outside rear-view mirrors are retracted.
- The wiper arms are secured in place with tape.
- If your vehicle is equipped with the pillar antenna, it can be retracted.
- If your vehicle is equipped with the roof antenna, it can be removed.
- If your vehicle is equipped with the rear gate spoiler, consult a car wash operator before using the car wash.
- If your vehicle has rain sensor wipers, place the wiper switch lever in the “OFF” position to deactivate the rain sensor.
- If your vehicle is equipped with the Ultra-sonic misacceleration Mitigation System (UMS), turn off the system. Refer to “FCM and UMS ON/OFF switch” on page 6-85.

### During cold weather

The salt and other chemicals spread on the roads in some areas in winter can have a harmful effect on the vehicle body. You should therefore wash the vehicle as often as possible in accordance with our care-instructions. It is recommended to have a preservative applied and the underfloor protection checked before and after the cold weather season.

After washing your vehicle, wipe off all waterdrops from the rubber parts around the doors to prevent the doors from freezing.

### Waxing

E00901001945

Waxing the vehicle will help prevent the adherence of dust and road chemicals to the paintwork. Apply a wax solution after washing the vehicle, or at least once every three months to assist displacing of water.

Do not wax your vehicle in direct sunlight. You should wax after the surfaces have cooled.

For information on how to use wax refer to the instruction manual of the wax.

### CAUTION

- Waxes containing high abrasive compounds should not be used.

### Polishing

E00901101180

The vehicle should only be polished if the paintwork has become stained or lost its lustre. Do not polish parts with a mat coating and the plastic bumpers. Doing so could cause stains or damage the finish.

## Cleaning plastic parts

E00901301935

Use a sponge or chamois leather. If a car wax adheres on a grey or black rough surface of the bumper, moulding or lamps, the surface becomes white. In such a case, wipe it off using lukewarm water and soft cloth or chamois leather.

### CAUTION

- Do not use a scrubbing brush or other hard tools as they may damage the plastic part surface.
- Do not bring the plastic parts into contact with petrol, light oil, brake fluids, engine oils, greases, paint thinners, and sulphuric acid (battery electrolyte) which may crack, stain or discolour the plastic parts. If they touch the plastic parts, wipe them off with soft cloth, chamois or the like and an aqueous solution of neutral detergent then immediately rinse the affected parts with water.

## Chrome parts

E00901401213

In order to prevent spots and corrosion of chrome parts, wash with water, dry thoroughly, and apply a special protective coating. This should be done more frequently in winter.

## Aluminium wheels\*

E00901500347

1. Remove dirt using a sponge while sprinkling water on the vehicle.
2. Use neutral detergent on any dirt that cannot be removed easily with water. Rinse off the neutral detergent after washing the vehicle.
3. Dry the vehicle thoroughly using a chamois leather or a soft cloth.

### CAUTION

- Do not use a brush or other hard implement on the wheels. Doing so could scratch the wheels.
- Do not use any cleaner that contains an abrasive substance or is acidic or alkaline. Doing so could cause the coating on the wheels to peel or become discoloured or stained.
- Do not directly apply hot water using a steam cleaner or by any other means.
- Contact with seawater and road deicer can cause corrosion. Rinse off such substances as soon as possible.

## Window glass

E00901600117

The window glass can normally be cleaned using only a sponge and water. Glass cleaner can be used to remove oil, grease, insect carcasses, etc. After washing

the glass, wipe it dry with a clean, dry, soft cloth. Never use a cloth that is used for cleaning a painted surface to clean a window. Wax from the painted surface could get on the glass and lower glass transparency and visibility.

### NOTE

- To clean the inside of the rear window, always use a soft cloth and wipe the window glass along the demister heater element so as not to cause damage.

## Wiper blades

E00901701173

Use a soft cloth and glass cleaner to remove grease, insect carcasses, etc., from the wiper blades. Replace the wiper blades when they no longer wipe properly. (Refer to page 10-15.)

## Engine compartment

E00902100324

Clean the engine compartment at the beginning and end of winter. Pay particular attention to flanges, crevices and peripheral parts where dust containing road chemicals and other corrosive materials might collect.

## Cleaning the exterior of your vehicle

---

If salt and other chemicals are used on the roads in your area, clean the engine compartment at least every three months.

Never spray or splash water on the electrical components in the engine compartment, as this may cause damage.

Do not bring the nearby parts, the plastic parts and so on into contact with sulphuric acid (battery electrolyte) which may crack, stain or discolour them.

If they are in contact, wipe off with soft cloth, chamois or the like and an aqueous solution of neutral detergent then immediately rinse the affected parts with plenty of water.

## *Maintenance*

Service precautions .....	10-2
Catalytic converter .....	10-3
Bonnet .....	10-3
Engine oil .....	10-5
Engine coolant .....	10-6
Washer fluid .....	10-7
Brake fluid .....	10-7
Clutch fluid* .....	10-8
Power steering fluid .....	10-9
Battery .....	10-9
Tyres .....	10-11
Wiper blade rubber replacement .....	10-15
General maintenance .....	10-16
Fusible links .....	10-17
Fuses .....	10-17
Replacement of lamp bulbs .....	10-21

## Service precautions

### Service precautions

E01000102869

Adequate care of your vehicle at regular intervals serves to preserve the value and appearance as long as possible.

Some maintenance items can be carried out by the owner (do it yourself), while others should be carried out by an authorised MITSUBISHI MOTORS dealer (periodic inspection and maintenance). In the event a malfunction or a problem is discovered, have it corrected by an authorised MITSUBISHI MOTORS dealer. This section contains information on inspection maintenance procedures that you can do yourself. Follow the instructions and cautions for each of the various procedures.

10

### WARNING

- When checking or servicing the inside of the engine compartment, make sure the engine is switched off and has had a chance to cool down.
- If it is necessary to do work in the engine compartment with the engine running, be especially careful that your clothing, hair, etc., does not become caught by the fan, drive belts, or other moving parts.

### WARNING

- After performing the maintenance work, make sure that no tools or cloths are left behind in the engine compartment. If they are left behind, a fire or damage to the vehicle may occur.
- The fan may turn on automatically even if the engine is not running. Turn the ignition switch to “LOCK” position or put the operation mode in OFF to be safe while you work in the engine compartment.
- Do not smoke, cause sparks or allow open flames around fuel or battery. The fumes are flammable.
- Be extremely cautious when working around the battery. It contains poisonous and corrosive sulphuric acid.
- Do not get under your vehicle with just the body jack supporting it. Always use automotive jack stands.
- Improper handling of components and materials used in the vehicle can endanger your personal safety. Consult an authorised MITSUBISHI MOTORS dealer for necessary information.

Check items of engine compartment are located as shown in the figure below.

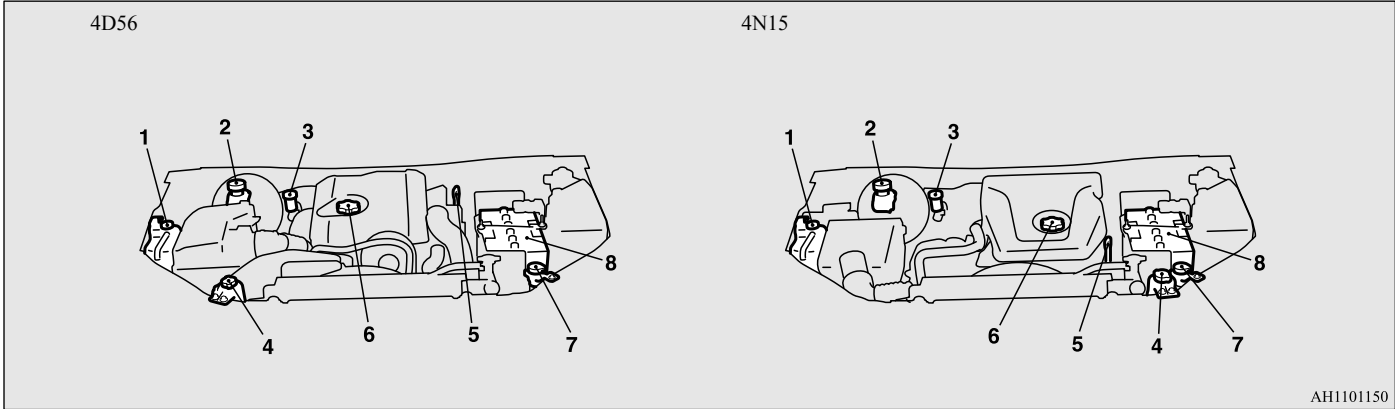

- 1. Engine coolant reservoir
- 2. Brake fluid reservoir
- 3. Clutch fluid reservoir\*
- 4. Power steering fluid reservoir
- 5. Engine oil level gauge
- 6. Engine oil cap
- 7. Washer fluid reservoir
- 8. Battery

The catalytic converter is installed in the exhaust system. It is important to keep the engine properly tuned to ensure proper catalyst operation and prevent possible catalyst damage.

**NOTE**

- Use fuel of the type recommended in “Fuel selection” on page 2-2.

**WARNING**

- As with any vehicle, do not park or operate this vehicle in areas where combustible materials such as dry grass or leaves can come in contact with a hot exhaust since a fire could occur.

**Catalytic converter**  
E01000202538

The exhaust gas scavenging devices used with the catalytic converter are extremely efficient for the reduction of noxious gases.

**Bonnet**  
E01000304461

**To open**

1. Pull the release lever towards you to unlock the bonnet.

## Bonnet

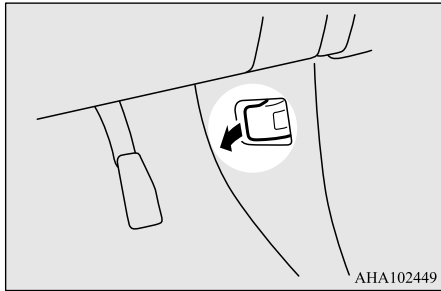

2. Raise the bonnet while pressing the safety lock.

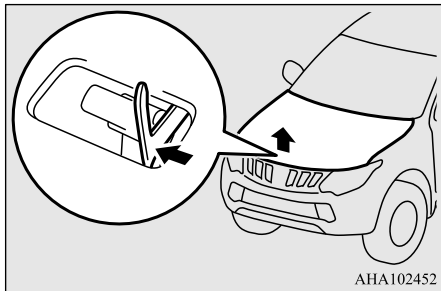

10

### NOTE

- Only open the bonnet when the wipers are in the parked position. Failure to do so may cause damage to the bonnet, wiper arms or front windscreen.

3. Support the bonnet by inserting the support bar in its slot.

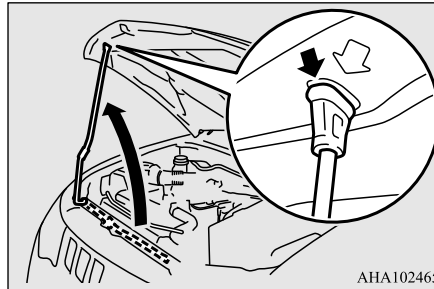

### CAUTION

- Note that the support bar may disengage the bonnet if the open bonnet is lifted by a strong wind.
- After inserting the support bar into the slot, make sure the bar supports the bonnet securely from falling down on to your head or body.

### To close

1. Unlatch the support bar and clip it in its holder.

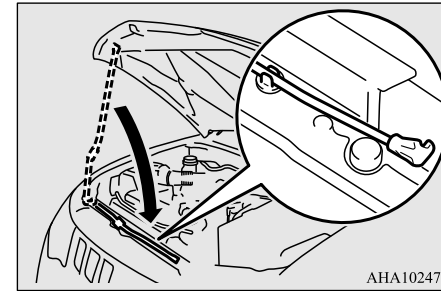

2. Slowly lower the bonnet to a position about 20 cm above the closed position, then let it drop.

3. Make sure the bonnet is securely locked by softly lifting the centre of the bonnet.

### CAUTION

- Be careful that hands or fingers are not trapped when closing the bonnet.
- Before driving, make sure that the bonnet is securely locked. An incompletely locked bonnet can suddenly open while driving. This can be extremely dangerous.

### NOTE

- If this does not close the bonnet, release it from a slightly higher position.
- Do not press down the bonnet hard with a hand as it may damage the bonnet.

## Engine oil

E01000404853

### To check and refill engine oil

A: Minimum level  
B: Maximum level

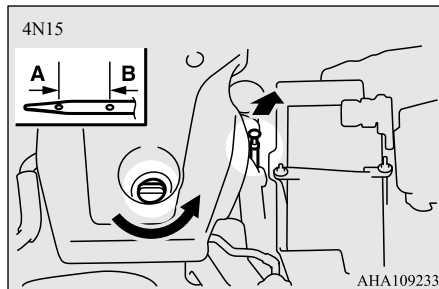
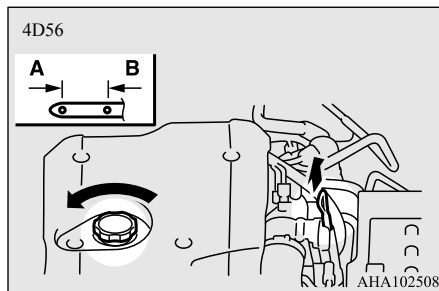

The engine oil used has a significant effect on the engine's performance, service life and startability. Be sure to use oil of the recommended quality and appropriate viscosity. All engines consume a certain amount of oil during normal operation. Therefore, it is important to check the oil level at regular intervals or before starting a long trip.

1. Park the car on a horizontal surface.
2. Switch off the engine.
3. Wait a few minutes.
4. Remove the dipstick and wipe it with a clean cloth.
5. Reinsert the dipstick as far as it goes.
6. Remove the dipstick and read the oil level, which should always be within the range indicated
7. If the oil level is below the specified limit, remove the cap located on the cylinder head cover and add enough oil to raise the level to within the specified range. Do not overfill to avoid engine damage. Be sure to use the specified engine oil and do not mix various types of oil.
8. After adding oil, close the cap securely.
9. Confirm the oil level by repeating step 4 to 6.

### NOTE

- The engine oil will deteriorate rapidly if the vehicle is subjected to severe conditions, requiring earlier oil replacement. Please refer to the maintenance schedule.
- For handling of used engine oils, refer to page 2-6.

### Selection of engine oil

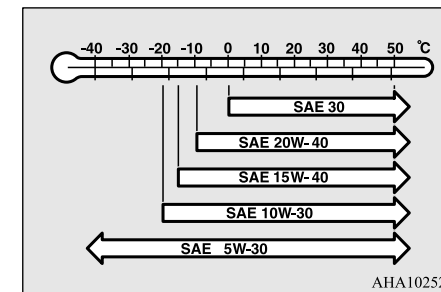

10

- Select engine oil of the proper SAE viscosity number according to the atmospheric temperature.
- Use engine oil conforming to the following classification:
  - ACEA classification: "For service A1/B1, A3/B3, A3/B4 or A5/B5"
  - API classification: "For service CD" or higher



## Engine coolant

### NOTE

- Use of additives is not recommended since they may reduce the effectiveness of additives already included in the engine oil. It may result in failure of the mechanical assembly.

## Engine coolant

E01000503583

### To check the coolant level

A translucent coolant reserve tank (A) is located in the engine compartment.

**10**

The coolant level in this tank should be kept between the “L” (LOW) and “F” (FULL) marks when measured while the engine is cold.

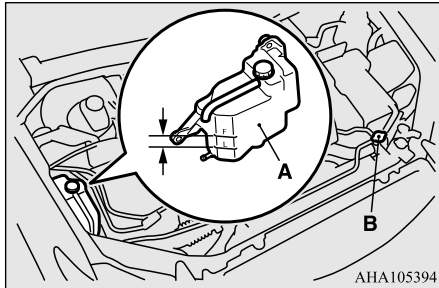

### To add coolant

The cooling system is a closed system and normally the loss of coolant should be very slight. A noticeable drop in the coolant level could indicate leakage. If this occurs, have the system checked at an authorised MITSUBISHI MOTORS dealer as soon as possible.

If the level should drop below the “L” (LOW) level on the reserve tank, open the lid and add coolant.

Also, if the reserve tank is completely empty, remove the radiator cap (B) and add coolant until the level reaches the filler neck.

### WARNING

- Do not open the radiator cap (B) while the engine is hot. The coolant system is under pressure and any hot coolant escaping could cause severe burns.

### Anti-freeze

The engine coolant contains an ethylene glycol anti-corrosion agent. Some parts of the engine are cast aluminium alloy, and periodic changing of the engine coolant is necessary to prevent corrosion of these parts.

Use “MITSUBISHI MOTORS GENUINE SUPER LONG LIFE COOLANT” or equivalent (4D56) or “MITSUBISHI MOTORS GENUINE SUPER LONG LIFE COOLANT PREMIUM” or equivalent\* (4N15).

\*: similar high quality ethylene glycol based non-silicate, non-amine, non-nitrate and non-borate coolant with long life hybrid organic acid technology

MITSUBISHI MOTORS GENUINE Coolant has excellent protection against corrosion and rust formation of all metals including aluminium and can avoid blockages in the radiator, heater, cylinder head, engine block, etc.

Because of the necessity of this anti-corrosion agent, the coolant must not be replaced with plain water even in summer. The required concentration of anti-freeze differs depending on the expected ambient temperature.

Ambient temperature (minimum) °C	-15	-20	-25	-30	-35	-50
Anti-freeze concentration %	50					60

**⚠ CAUTION**

- Do not use alcohol or methanol anti-freeze or any engine coolants mixed with alcohol or methanol anti-freeze. The use of an improper anti-freeze can cause corrosion of the aluminium components.
- For effective anti-corrosion and anti-freeze performance, keep the anti-freeze concentration within the range of 30 to 60%. Concentrations exceeding 60% will result in a reduction of both the anti-freeze and cooling performance thus adversely affecting the engine.
- Do not top up with water only. Water by itself reduces the rust-protective and anti-freeze qualities of the coolant and has a lower boiling point. It can also cause damage to the cooling system if it should freeze. Do not use tapwater, as it can cause corrosion and rust formation.

**During cold weather**

If the temperatures in your area drop below freezing, there is the danger that the coolant in the engine or radiator could freeze and cause severe damage to the engine and/or radiator. Add a sufficient amount of anti-freeze to the coolant to prevent it from freezing.

The concentration should be checked before the start of cold weather and anti-freeze added to the system if necessary.

**Washer fluid**

E01000702096

Open the washer fluid reservoir cap and check the level of washer fluid. If the level is low, replenish the container with washer fluid.

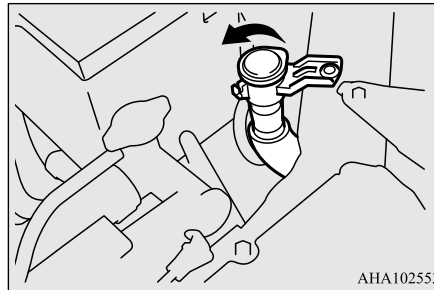

AHA102553

**NOTE**

- The washer fluid container serves the wind-screen.

**During cold weather**

To ensure proper operation of the washers at low temperatures, use a fluid containing an anti-freezing agent.

**Brake fluid**

E01000902144

**To check the fluid level**

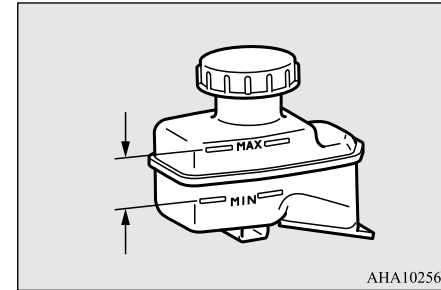

AHA102566

**10**

The brake fluid level must be between the “MAX” and “MIN” marks on the reservoir. The brake fluid level is monitored by a float. When the brake fluid level falls below the “MIN” mark, the brake fluid warning lamp lights up. The fluid level falls slightly with wear of the brake pads, but this does not indicate any abnormality.

## Clutch fluid\*

If the brake fluid level falls markedly in a short length of time, it indicates leaks from the brake system.

If this occurs, have the vehicle checked by an authorised MITSUBISHI MOTORS dealer.

### Fluid type

Use brake fluid conforming to DOT3 or DOT4 from a sealed container. The brake fluid is hygroscopic. Too much moisture in the brake fluid will adversely affect the brake system, reducing the brake performance.

10

### ⚠ WARNING

- Take care in handling brake fluid as it is harmful to the eyes, may irritate your skin and will damage to painted surfaces. Wipe up spills immediately. If brake fluid gets on your hands or in your eyes, flush immediately with clean water. Follow up with a doctor as necessary.

### ⚠ CAUTION

- Use only the specified brake fluid. Do not mix or add different brand of brake fluid to prevent chemical reaction. Do not let any petroleum-based fluid touch, mix with, or get into the brake fluid. This will damage the seals.

### ⚠ CAUTION

- Keep the reservoir tank cap closed to prevent the brake fluid from deteriorating except maintenance.
- Clean the filler cap before removing and close the cap securely after maintenance.

### Clutch fluid\*

E01001001594

### To check the fluid level

The clutch fluid in the master cylinder should be checked when performing other under-hood service. In addition, the system should be checked for leakage at the same time. Check to make certain that the clutch fluid level is always between the “MAX” and “MIN” level markings on the fluid reservoir.

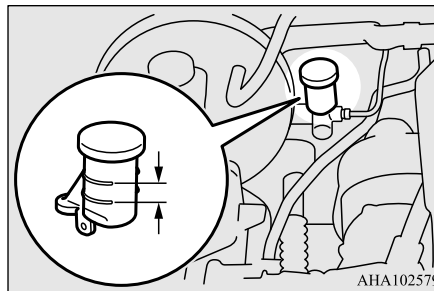

A rapid fluid loss indicates a leak in the clutch system which should be inspected by your authorised MITSUBISHI MOTORS dealer and repaired immediately.

### Fluid type

Brake fluid conforming to DOT 3 or DOT 4 should be used.

The reservoir cap must be fully tightened to avoid contamination from foreign matter or moisture.

DO NOT ALLOW PETROLEUM- BASED FLUID TO CONTACT, MIX WITH, OR OTHERWISE CONTAMINATE THE BRAKE FLUID. SEAL DAMAGE WILL RESULT.

### ⚠ WARNING

- Take care in handling brake fluid as it is harmful to the eyes, may irritate your skin and will damage to painted surfaces. Wipe up spills immediately. If brake fluid gets on your hands or in your eyes, flush immediately with clean water. Follow up with a doctor as necessary.

## Power steering fluid

E01001102390

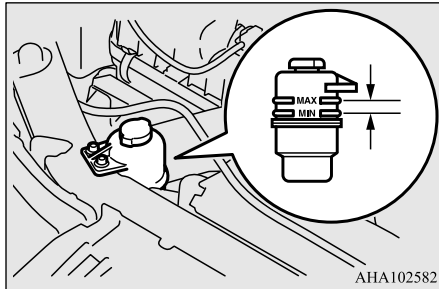

AHA102582

### To check the fluid level

Check the fluid level in the reservoir while the engine is idling.

Check to make certain that the power steering fluid level is always between the “MAX” and “MIN” level markings on the fluid reservoir and refill the fluid, if necessary.

### Fluid type

Use “MITSUBISHI MOTORS GENUINE PSF (Power Steering Fluid)”.

## Battery

E01001203503

The condition of the battery is very important for quick starting of the engine and proper functioning of the vehicle’s electrical system. Regular inspection and care are especially important in cold weather.

### Battery precautions

#### ⚠ WARNING

- Note operating instructions



When you handle the battery, carefully observe the following cautions for safety.

- No smoking, no naked flames, no sparks



Keep sparks, cigarettes, and flames away from the battery because the battery could explode. Also, do not short-circuit the battery terminals. Doing so could create sparks.

#### ⚠ WARNING

- Shield eyes



Always wear protective eye goggles when working near the battery. Battery electrolyte contains sulphuric acid, so getting it in your eyes is dangerous.

- Battery acid



Battery electrolyte contains sulphuric acid, so you must wear gloves and eye protection when handling the battery.

If battery electrolyte gets in your eyes or on your skin, rinse it away with clean water and immediately see a doctor.

If you accidentally swallow battery electrolyte, immediately see a doctor.

If battery electrolyte splashes on your clothing or on the vehicle, rinse it off with lots of water.

- Explosive gas



The battery emits highly explosive hydrogen gas. Ventilate when charging the battery in an enclosed space.

## Battery

### ⚠ WARNING

- Keep away from children



Keep it out of reach of children.

### Checking battery electrolyte level

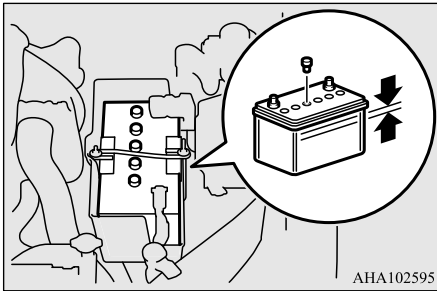

The electrolyte level must be between the specified limit on the outside of the battery. Replenish with distilled water as necessary.

The inside of the battery is divided into several compartments; remove the cap from each compartment and fill to the upper mark. Do not top up beyond the upper mark because spillage during driving could cause damage.

Check the electrolyte level at least once every four weeks, depending on the operating conditions.

If the battery is not used, it will discharge by itself with time. Check it once every four weeks and charge with low current as necessary.

### During cold weather

The capacity of the battery is reduced at low temperatures. This is an inevitable result of its chemical and physical properties. This is why a very cold battery, particularly one that is not fully charged, will only deliver a fraction of the starter current which is normally available.

It is recommended that you have the battery checked by an authorised MITSUBISHI MOTORS dealer before the start of cold weather and, if necessary, have it charged.

This does not only ensure reliable starting, but a battery which is kept fully charged also has a longer life.

### Disconnection and connection

To disconnect the battery cable, stop the engine, first disconnect the negative (-) terminal and then the positive (+) terminal. When connecting the battery, first connect the

positive (+) terminal and then the negative (-) terminal.

### NOTE

- Open the terminal cover (A) before disconnecting or connecting the positive (+) terminal of the battery.
- Loosen the nut (B), and then disconnect the battery cable from the positive (+) terminal.

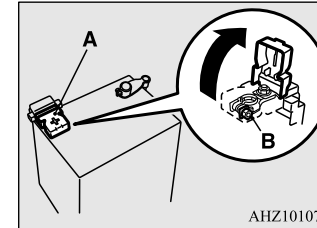

### ⚠ WARNING

- Keep sparks, cigarettes, and flames away from the battery because the battery could explode.
- The battery electrolyte is extremely caustic. Do not allow it to come in contact with your eyes, skin, clothing, or the painted surfaces of the vehicle. Spilt electrolyte should be flushed immediately with ample amounts of water. Irritation to eyes or skin from contact with electrolyte requires immediate medical attention.

**⚠ WARNING**

- **Ventilate when charging or using the battery in an enclosed space.**

**⚠ CAUTION**

- Never disconnect the battery with the ignition switch or the operation mode in the "ON"; doing so could damage the vehicle's electrical components.
- Never short-circuit the battery; doing so could cause it to overheat and be damaged.
- Always wear protective eye goggles when working near the battery.
- If the battery is to be quick-charged, first disconnect the battery cables.
- In order to prevent a short circuit, be sure to disconnect the negative (-) terminal first.
- Keep it out of reach of children.
- Do not bring the nearby parts, the plastic parts and so on into contact with sulphuric acid (battery electrolyte) which may crack, stain or discolour them.

If they are in contact, wipe off with soft cloth, chamois or the like and an aqueous solution of neutral detergent then immediately rinse the affected parts with plenty of water.

**📖 NOTE**

- Keep the terminals clean. After the battery is connected, apply terminal protection grease. To clean the terminals, use lukewarm water.
- Check to see if the battery is securely installed and cannot be moved during travel. Also check each terminal for tightness.
- When the vehicle is to be left unused for a long period of time, remove the battery and store it in a place where the battery fluid will not freeze. The battery should be stored only in a fully charged condition.

**Tyres**

E01001300242

**⚠ WARNING**

- **Driving with tyres that are worn, damaged or improperly inflated can lead to a loss of control or blow out of the tyres which can result in a collision with serious or fatal injury.**

## Tyres

### Tyre inflation pressures

E01001404788

Tyre size	No cargo		Cargo	
	Front	Rear	Front	Rear
265/60R18 110H	220 kPa (32 p.s.i./ 2.2 kgf/cm <sup>2</sup> )	220 kPa (32 p.s.i./ 2.2 kgf/cm <sup>2</sup> )	220 kPa (32 p.s.i./ 2.2 kgf/cm <sup>2</sup> )	290 kPa (42 p.s.i./ 2.9 kgf/cm <sup>2</sup> )
245/65R17 111S RF	220 kPa (32 p.s.i./ 2.2 kgf/cm <sup>2</sup> )	220 kPa (32 p.s.i./ 2.2 kgf/cm <sup>2</sup> )	220 kPa (32 p.s.i./ 2.2 kgf/cm <sup>2</sup> )	290 kPa (42 p.s.i./ 2.9 kgf/cm <sup>2</sup> )
245/70R16 111S RF	200 kPa (29 p.s.i./ 2.0 kgf/cm <sup>2</sup> )	200 kPa (29 p.s.i./ 2.0 kgf/cm <sup>2</sup> )	200 kPa (29 p.s.i./ 2.0 kgf/cm <sup>2</sup> )	290 kPa (42 p.s.i./ 2.9 kgf/cm <sup>2</sup> )
205R16C 110/108R 8PR	240 kPa (35 p.s.i./2.4 kgf/cm <sup>2</sup> )	240 kPa (35 p.s.i./2.4 kgf/cm <sup>2</sup> )	240 kPa (35 p.s.i./2.4 kgf/cm <sup>2</sup> )	450 kPa (65 p.s.i./4.5 kgf/cm <sup>2</sup> )
225/65R16C 112/110R	200 kPa (29 p.s.i./ 2.0 kgf/cm <sup>2</sup> )	200 kPa (29 p.s.i./ 2.0 kgf/cm <sup>2</sup> )	200 kPa (29 p.s.i./ 2.0 kgf/cm <sup>2</sup> )	375 kPa (54 p.s.i./ 3.75 kgf/cm <sup>2</sup> )
195R15C 106/104R 8PR	220 kPa (32 p.s.i./ 2.2 kgf/cm <sup>2</sup> )	220 kPa (32 p.s.i./ 2.2 kgf/cm <sup>2</sup> )	220 kPa (32 p.s.i./ 2.2 kgf/cm <sup>2</sup> )	450 kPa (65 p.s.i./4.5 kgf/cm <sup>2</sup> )

**10**

Check the tyre inflation pressure of all the tyres while they are cold; if insufficient or excessive, adjust to the specified value. After the tyre inflation pressure has been adjusted, check the tyres for damage and air leaks. Be sure to put caps on the valves.

## Wheel condition

E01001802007

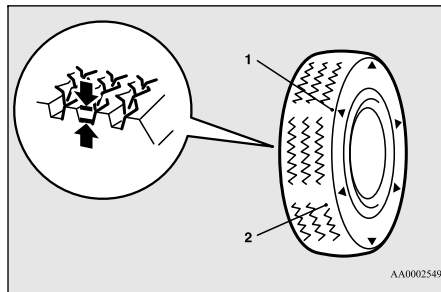

- 1- Location of the tread wear indicator
- 2- Tread wear indicator

Check the tyres for cuts, cracks and other damage. Replace the tyres if there are deep cuts or cracks. Also check each tyre for pieces of metal or pebbles.

The use of worn tyres can be very dangerous because of the greater chance of skidding or hydroplaning. The tread depth of the tyres must exceed 1.6 mm in order for the tyres to meet the minimum requirement for use.

Tread wear indicators will appear on the surface of the tyre as the tyre wears, thereby indicating that the tyre no longer meets the minimum requirement for use. When these wear indicators appear, the tyres must be replaced with new ones.

In the case of the 4-wheel drive vehicles, when replacement of any of the tyres is necessary, replace all of them.

### ⚠ CAUTION

- Always use tyres of the same size, same type, and same brand, and which have no wear differences. Using tyres of different size, type, brands or degree of wear, will increase the differential oil temperature, resulting in possible damage to the driving system. Further, the drive train will be subjected to excessive loading, possibly leading to oil leakage, component seizure, or other serious faults.

## Replacing tyres and wheels

E01007201556

### ⚠ CAUTION

- Avoid using different size tyres from the one listed and the combined use of different types of tyres, as this can affect driving safety.  
Refer to “Tyres and wheels” on page 11-13.
- Even if a wheel has the same rim size and offset as the specified type of wheel, its shape may prevent it from being fitted correctly. Consult an authorised MITSUBISHI MOTORS dealer before using wheels that you have.

## Tyre rotation

E01001902675

Tyre wear varies with vehicle conditions, road surface conditions and individual driver's driving habits. To equalize the wear and help extend tyre life, it is recommended to rotate the tyres immediately after discovery of abnormal wear, or whenever the wear difference between the front and rear tyres is recognizable.

When rotating tyres, check for uneven wear and damage. Abnormal wear is usually caused by incorrect tyre pressure, improper wheel alignment, out of balance wheel, or severe braking. Consult your authorised MITSUBISHI MOTORS dealer to determine the cause of irregular tread wear.



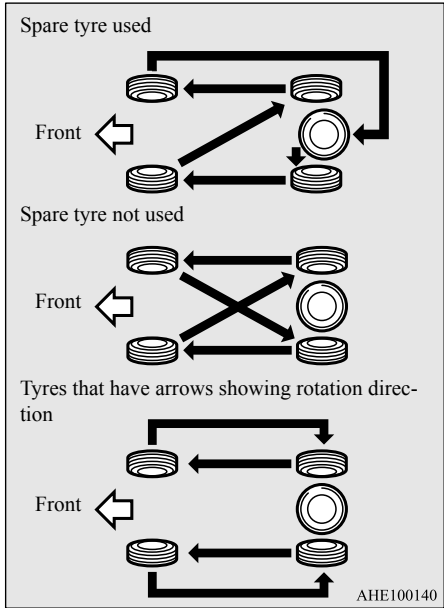

**CAUTION**

- If the tyres have arrows (A) indicating the correct direction of rotation, swap the front and rear tyres on the left hand side of the vehicle and the front and rear tyres on the right hand side of the vehicle separately. Keep each tyre on its original side of the vehicle. When fitting the tyres, make sure the arrows point in the direction in which the wheels will turn when the vehicle moves forward. Any tyre whose arrow points in the wrong direction will not perform to its full potential.

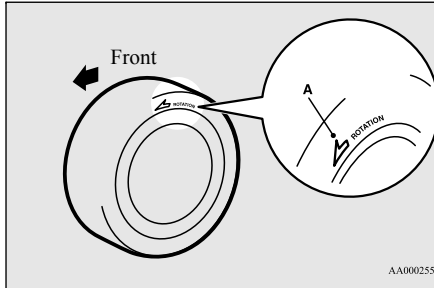

**CAUTION**

- Avoid the combined use of different types of tyres. Using different types of tyres can affect vehicle performance and safety.

**Snow tyres**

E01002000549

The use of snow tyres is recommended for driving on snow and ice. To preserve driving stability, mount snow tyres of the same size and tread pattern on all four wheels. Snow tyres worn more than 50 % are no longer suitable for use as snow tyres. Snow tyres which do not meet specifications must not be used.

**CAUTION**

- Observe permissible maximum speed for your snow tyres and the legal speed limit.

**NOTE**

- The laws and regulations concerning snow tyres (driving speed, required use, type, etc.) vary. Find out and follow the laws and regulations in the area you intend to drive.
- If flange nuts are used on your vehicle, change to tapered nuts when steel wheels are used.

**Tyre chains**

E01002103062

It is recommended that snow chains are carried in snow regions and fitted when required to the rear wheels.

On 4WD vehicles in which the driving power is distributed preferentially to the rear wheels, ensure that the tyre chains are fitted on the rear.

The tyres fitted to your vehicle as original equipment allow you to fit tyre chains if they are required. When replacing your tyres, check with the tyre distributor or manufacturer if the fitting of tyre chains will be detrimental to the tyres being purchased.

Always follow the chain manufacturer's instructions when fitting the chains.

### ⚠ WARNING

- **DO NOT use a jack when fitting the chains, as in the conditions, the tyres may slip on the icy road causing the vehicle to slip off the jack.**

### ⚠ CAUTION

- Choose a clear straight stretch of road where you can pull off and still be seen while you are fitting the chains.
- Do not fit chains before you need them. This will wear out your tyres and the road surface.
- After driving around 100-300 metres, stop and retighten the chains.
- Care should be taken with extremes of steering lock to prevent possible contact between the chains and the vehicle body.

### ⚠ CAUTION

- Drive carefully and do not exceed 30 km/h. Remember, fitting chains is not going to stop accidents from happening.
- When tyre chains are installed, take care that they do not damage the disc wheel or body.
- An aluminium wheel can be damaged by a tyre chain while driving. When fitting a tyre chain on an aluminium wheel, take care that any part of the chain and fitting cannot be brought into contact with the wheel.
- When installing or removing a tyre chain, take care that hands and other parts of your body are not injured by the sharp edges of the vehicle body.
- Install the chains only on the rear tyres and tighten them as tightly as possible with the ends securely fastened.

### 📖 NOTE

- The laws and regulations concerning the use of tyre chains vary. Find out and follow the laws and regulations in driving area. In most countries, it is prohibited by the law to use tyre chains on roads without snow.

## Wiper blade rubber replacement

E01008201380

1. Lift the wiper arm off the windscreen.

## Wiper blade rubber replacement

2. Pull the wiper blade until its stopper (A) disengages from the hook (B). Pull the wiper blade further to remove it.

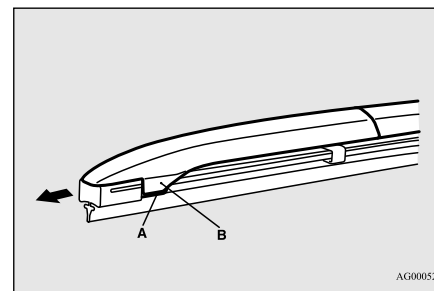

### 📖 NOTE

- Do not allow the wiper arm to fall onto the windscreen. This could damage the glass.

10

3. Attach the retainers (C) to a new wiper blade. Refer to the illustration to ensure that the retainers are correctly aligned as you attach them.

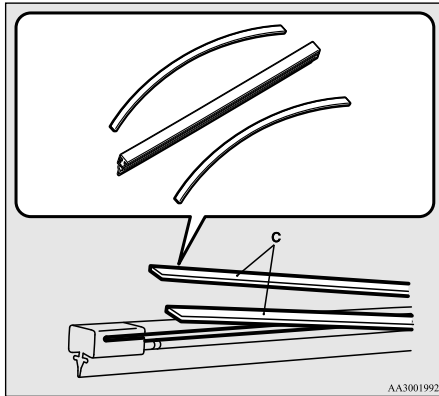

**10**

4. Insert the wiper blade into the arm, starting with the opposite end of the blade from the stopper. Make sure the hook (B) is fitted correctly in the grooves in the blade.

**NOTE**

- If retainers are not supplied with the new wiper blade, use the retainers from the old blade.

5. Push the wiper blade until the hook (B) engages securely with the stopper (A).

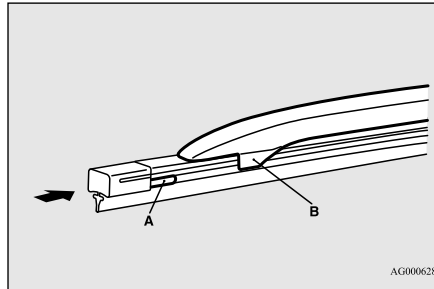

**General maintenance**

E01002701602

**Fuel, engine coolant, oil and exhaust gas leakage**

Look under the body of your vehicle to check for fuel, engine coolant, oil and exhaust gas leaks.

**WARNING**

- If you see a suspicious fuel leak or if you smell fuel, do not operate the vehicle; call your authorised MITSUBISHI MOTORS dealer for assistance.

**Exterior and interior lamp operation**

Operate the combination lamp switch to check that all lamps are functioning properly. If the lamps do not illuminate, the probable cause is a blown fuse or defective lamp bulb. Check the fuses first. If there is no blown fuses, check the lamp bulbs.

For information regarding the inspection and replacement of the fuses and the lamp bulbs, refer to “Fuses” on page 10-17 and “Replacement of lamp bulbs” on page 10-21.

If the fuses and bulbs are all OK, take the vehicle to an authorised MITSUBISHI MOTORS dealer for inspection and repair.

**Meter, gauge and indicator/warning lamps operation**

Run the engine to check the operation of all meters, gauges, and indicator/warning lamps. If there is anything wrong, take the vehicle to an authorised MITSUBISHI MOTORS dealer for inspection.

**Hinges and latches lubrication**

Check all latches and hinges, and, if necessary, have them lubricated.

## Fusible links

E01002901675

The fusible links will melt to prevent a fire if a large current attempts to flow through certain electrical systems.

In case of a melted fusible link, see your authorised MITSUBISHI MOTORS dealer for inspection and replacement.

For the fusible links, please refer to “Passenger compartment fuse location table” on page 10-18 and “Engine compartment fuse location table” on page 10-19.

**⚠ WARNING**

- **Fusible links must not be replaced by any other device. Failing to fit the correct fusible link may result in fire in the vehicle, property destruction and serious or fatal injuries at any time.**

## Fuses

E01003001211

### Fuse block location

E01007601778

To prevent damage to the electrical system due to short-circuiting or overloading, each individual circuit is provided with a fuse.

There are fuse blocks in the passenger compartment and in the engine compartment.

## Passenger compartment

The fuse block in the passenger compartment is located behind the glove box at the position shown in the illustration.

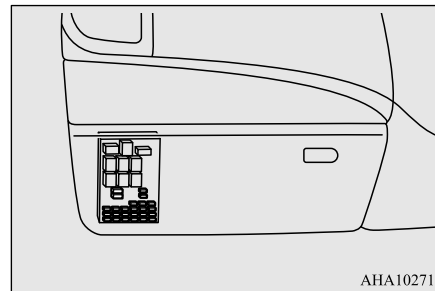

1. Open the glove box.
2. Move the rod (A) on the right side of the glove box to the right side of the box. (if so equipped)

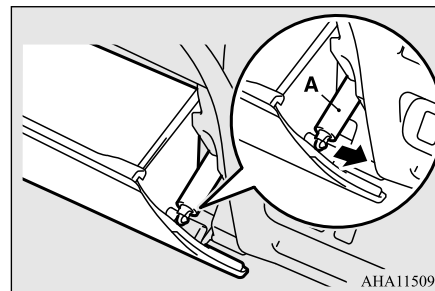

3. While pressing the side of the glove box, unhook the left and right hooks (B) and lower the glove box.

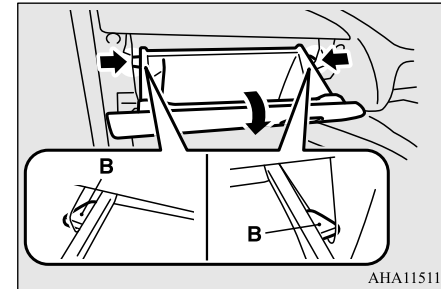

4. Remove the glove box fastener (C), and then remove the glove box.

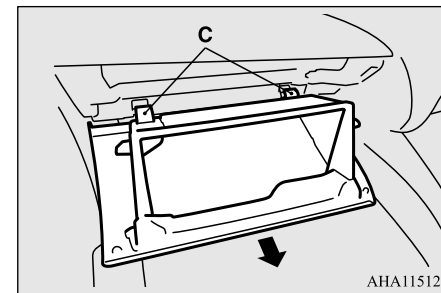

10

## Fuses

### Engine compartment

In the engine compartment, the fuse block is located as shown in the illustration.

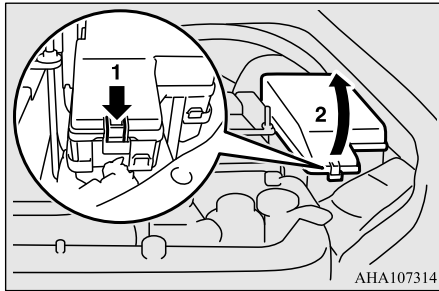

**10**

- 1- Push the tab.
- 2- Remove the cover.

### Fuse load capacity

E01007701809

The fuse capacity and the name of the electrical systems protected by the fuses are indicated on the back of the glove box and on the inside of the fuse block cover for fuses located in the engine compartment.

#### NOTE

- Spare fuses are provided in the fuse block of the engine compartment. Always use a fuse of the same capacity for replacement.







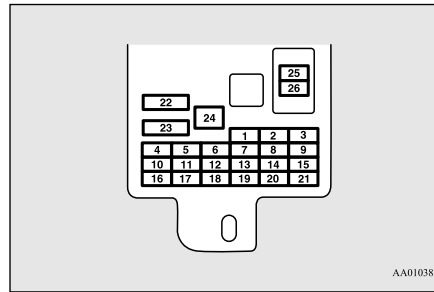

10-18 Maintenance

















### Passenger compartment fuse location table

E01007902286



AA0103837

No.	Symbol	Electrical system	Capacity
1		Tail lamp (left)	7.5 A
2		Cigarette lighter/ Accessory socket	15 A
3		Ignition coil	10 A
4		Starter motor	7.5 A
5		Sunroof	20 A
6		Accessory socket	15 A
7		Tail lamp (right)	7.5 A
8		Outside rear-view mirrors	7.5 A
9		Engine control unit	7.5 A

No.	Symbol	Electrical system	Capacity
10		Control unit	7.5 A
11		Rear fog lamp	10 A
12		Central door lock	15 A
13		Room lamp	15 A
14		Rear window wiper	15 A
15		Gauge	10 A
16		Relay	7.5 A
17		Heated seat	20 A
18		Option	10 A
19		Heated door mirror	7.5 A
20		Windscreen wiper	20 A
21		Reversing lamps	7.5 A
22		Demister	30 A
23		Heater	30 A
24		Power seat	40 A*
25		Radio	10 A
26		Electronic controlled unit	20 A

\*: Fusible link

- Some fuses may not be installed on your vehicle, depending on the vehicle model or specifications.
- The table above shows the main equipment corresponding to each fuse.

### Engine compartment fuse location table

E01008002617

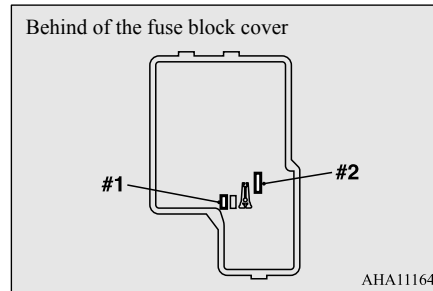
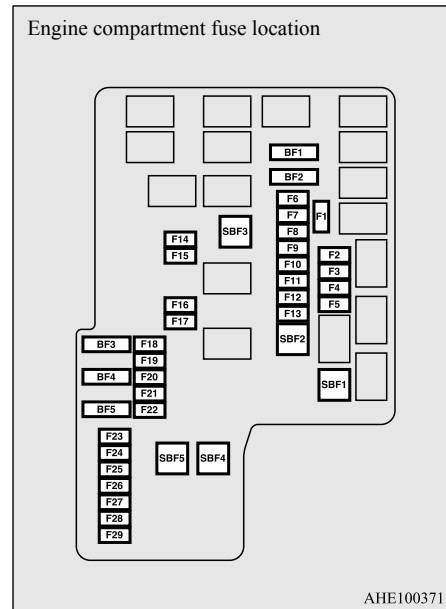













No.	Symbol	Electrical system	Capacities
SBF1		Ignition switch	40 A*
SBF2		Electric window control	30 A*
SBF3		Power seat	40 A*
SBF4		Anti-lock braking system	30 A*
SBF5		Electric parking brake	30 A*
BF1		Audio system amp	30 A
BF2		Rear air conditioning	30 A
		Rear circulator	
BF3	—	—	—

No.	Symbol	Electrical system	Capacities
BF4		DC-DC(AUDIO)	30 A
BF5		DC-DC(A/T)	30 A
		UREA SCR	
F1		NOX sensor	10 A
F2		Engine	20 A
F3		Fuel pump	15 A
		Fuel pump/PM-NOX sensor	
F4		IBS	7.5 A
F5		Starter	7.5 A
F6		Fuel line heater	20 A
		ETV	
F7		Air conditioning	20 A
F8		Automatic transmission	20 A
F9		Daytime running lamps	10 A
F10		Alternator	7.5 A
F11		Engine control	7.5 A
F12		Ignition coil	10 A
F13		Front fog lamps	15 A

## Fuses

10

No.	Symbol	Electrical system	Capacities
F14		Headlamp high beam (left)	10 A
F15		Headlamp high beam (right)	10 A
F16		Headlamp low beam (left)	15 A
F17		Headlamp low beam (right)	15 A
F18		Steering heater	15 A
F19		Hazard warning flasher	15 A
F20	—	—	—
F21		Radiator fan motor	20 A
F22	STOP	Stop lamps (Brake lamps)	15 A
F23	T/F	T/F	20 A
F24		Rear heated seat	20 A
F25		Headlamp washer	20 A
F26		Security horn	20 A
F27		Horn	10 A
F28	—	—	—

No.	Symbol	Electrical system	Capacities
F29		AC inverter	20 A
#1	—	Spare fuse	20 A
#2	—	Spare fuse	30 A

\*: Fusible link

- Some fuses may not be installed on your vehicle, depending on the vehicle model or specifications.
- The table above shows the main equipment corresponding to each fuse.

The fuse block does not contain spare 7.5 A, 10 A or 15 A fuses. If one of these fuses burns out, substitute with the following fuse.

**7.5 A: Outside rear-view mirrors**

**10 A: Option**

**15 A: Cigarette lighter**

When using a substitute fuse, replace with a fuse of the correct capacity as soon as possible.

### Identification of fuse

E01008100366

Capacity	Colour
7.5 A	Brown
10 A	Red

Capacity	Colour
15 A	Blue
20 A	Yellow
30 A	Green (fuse type) / Pink (fusible link type)
40 A	Green (fusible link type)

### Fuse replacement

E01007802113

1. Before replacing a fuse, always turn off the electrical circuit concerned and place the ignition switch in the “LOCK” position or put the operation mode in OFF.
2. Remove the fuse puller (A) from the inside of the fuse block (Type 1) or the fuse block cover (Type 2) in the engine compartment.

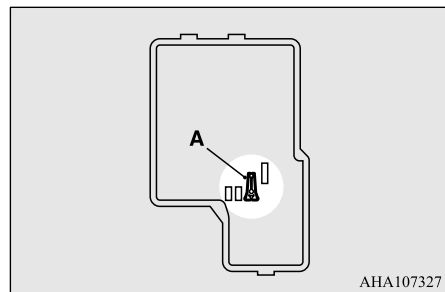

3. Referring to the fuse load capacity table, check the fuse pertaining to the problem.

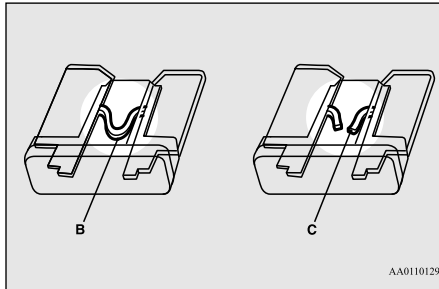

B- Fuse is OK  
C- Blown fuse

**NOTE**

- If any system does not function but the fuse corresponding to that system is normal, there may be a fault in the system elsewhere. Have your vehicle checked by an authorised MITSUBISHI MOTORS dealer.

4. Insert a new fuse of the same capacity by using the fuse puller into the same place at the fuse block.

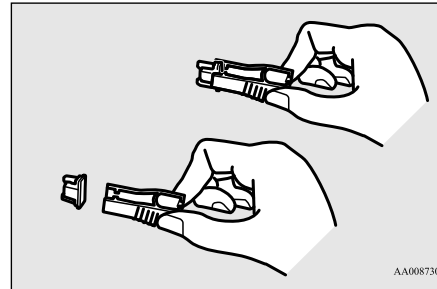

**CAUTION**

- If the newly inserted fuse blows again after a short time, have the electrical system checked by an authorised MITSUBISHI MOTORS dealer to find the cause and rectify it.
- Never use a fuse with a capacity larger than that specified or any substitute, such as wire, foil, etc.; doing so will cause the circuit wiring to heat up and could cause a fire.

**Replacement of lamp bulbs**

E01003102147

Before replacing a bulb, ensure the lamp is off. Do not touch the glass part of the new bulb with your bare fingers; the skin oil left on the glass will evaporate when the bulb gets hot and the vapor will condense on the reflector and dim the surface.

**CAUTION**

- Bulbs are extremely hot immediately after being turned off. When replacing a bulb, wait for it to cool sufficiently before touching it. You could otherwise be burnt.
- Handle halogen lamp bulb with care. The gas inside halogen lamp bulb is highly pressurized, so dropping, knocking, or scratching a halogen lamp bulb can cause it to shatter.
- Never hold the halogen lamp bulb with a bare hand, dirty glove, etc. The oil from your hand could cause the bulb to break the next time the headlamps are operated. If the glass surface is dirty, it must be cleaned with alcohol, paint thinner, etc., and refit it after drying it thoroughly.

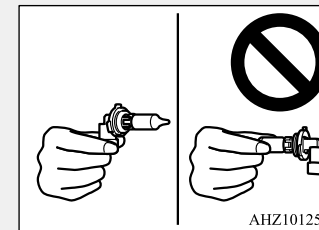

- Do not install commercially available LED-type bulbs. Commercially available LED-type bulbs could adversely affect the operation of the vehicle, such as by preventing the lamps and other vehicle equipment from operating properly.



## Replacement of lamp bulbs

### NOTE

- If you are unsure of how to carry out the work as required, it is recommended that these procedures be carried out by an authorised MITSUBISHI MOTORS dealer.
- Be careful not to scratch the vehicle body when removing a lamp and lens.
- When it rains, or when the vehicle has been washed, the inside of the lens sometimes becomes foggy. This is the same phenomenon as when window glass mists up on a humid day, and does not indicate a functional problem. When the lamp is switched on, the heat will remove the fog. However, if water gathers inside the lamp, please go to an authorised MITSUBISHI MOTORS dealer for a check.

10

### Bulb location and capacity

E01003201587

### CAUTION

- When replacing a bulb, be sure to use a new bulb of the same type, wattage, and colour. If you install a different bulb, the bulb could malfunction or fail to come on and could lead to a vehicle fire.

### Outside

E01003305791

#### ■ Front

#### Halogen headlamps type

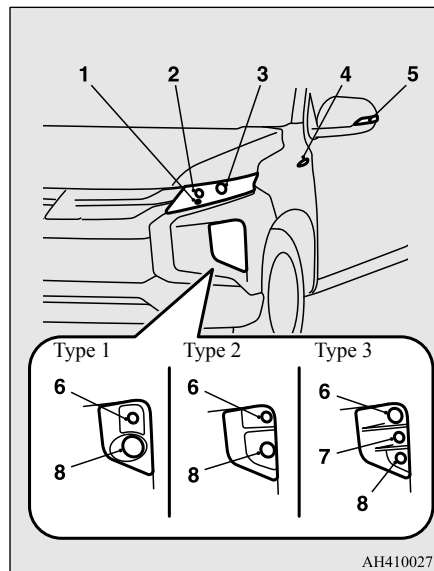

AH4100271

- 1- Position lamps: 5 W (W5W)
- 2- Headlamps, high beam: 60 W (HB3)
- 3- Headlamps, low beam: 55 W (H11)
- 4- Side turn-signal lamps (on fender)\*: 5W

- 5- Side turn-signal lamps (on outside rear-view mirror)\*: —
- 6- Front turn-signal lamps: 21 W (PY21W)
- 7- Daytime running lamps: 13 W (P13W)
- 8- Type 1  
Front fog lamps\*: 19 W (H16)  
Daytime running lamps\*: 13W (P13W)  
Type 2  
Front fog lamps\*: 35 W (H8)  
Type 3  
Front fog lamps\*: 35 W (H8)

Codes in parentheses indicate bulb types.

### NOTE

- It is not possible to repair or replace only the bulb of each side turn-signal lamp (on fender). For repair and replacement, contact an authorised MITSUBISHI MOTORS dealer when the lamp needs to be repaired or replaced.
- The side turn-signal lamps (on outside rear-view mirror) use an LED instead of the bulb. If you need to repair or replace these lamps, contact an authorised MITSUBISHI MOTORS dealer.

**LED headlamps type**

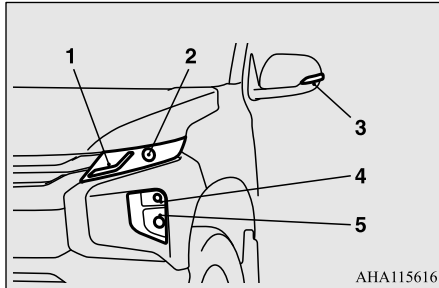

- 1- Position lamps/Daytime running lamps: —
- 2- Headlamps, high/low beam: —
- 3- Side turn-signal lamps: —
- 4- Front turn-signal lamps: 21 W (PY21W)
- 5- Front fog lamps: 35 W (H8)

Codes in parentheses indicate bulb types.

**NOTE**

- The following lamps use an LED instead of the bulb. If you need to repair or replace these lamps, contact an authorised MITSUBISHI MOTORS dealer.
  - Headlamps
  - Position lamps/Daytime running lamps
  - Side turn-signal lamps

**■ Rear**

**Type A**

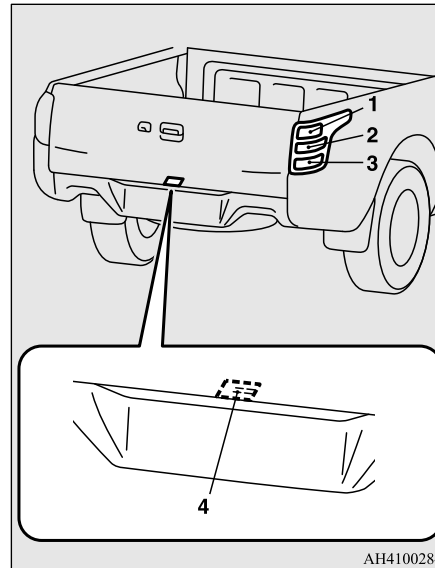

- 1- Tail and stop lamps: 21/5 W (P21/5W)
- 2- Rear turn-signal lamps: 21 W (PY21W)
- 3- Reversing lamps: 21 W (P21W)
- 4- Licence plate lamps: 5 W (W5W)

Codes in parentheses indicate bulb types.

**NOTE**

- The high-mounted stop lamp uses an LED instead of the bulb. If you need to repair or replace the lamp, contact an authorised MITSUBISHI MOTORS dealer.

**Type B**

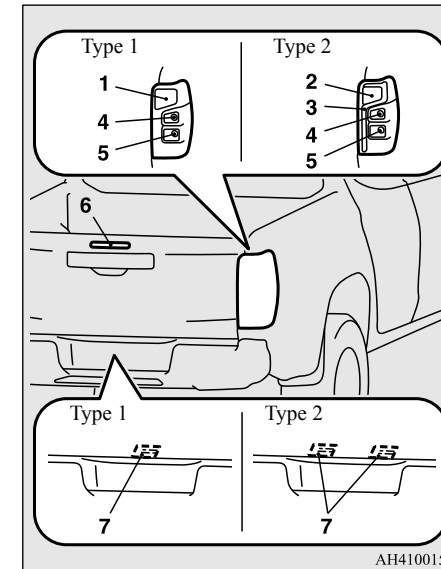

- 1- Tail and stop lamps: —
- 2- Stop lamps: —
- 3- Tail lamps: —

## Replacement of lamp bulbs

- 4- Rear turn-signal lamps: 21 W (PY21W)
- 5- Reversing lamps: 18 W (W16W)
- 6- High-mounted stop lamp\*: —
- 7- Licence plate lamps: 5 W (W5W)

Codes in parentheses indicate bulb types.

### NOTE

- The following lamps use an LED instead of the bulb.  
If you need to repair or replace these lamps, contact an authorised MITSUBISHI MOTORS dealer.
  - Tail and stop lamps
  - Stop lamps
  - Tail lamps
  - High-mounted stop lamp

10

## Inside

E01003403987

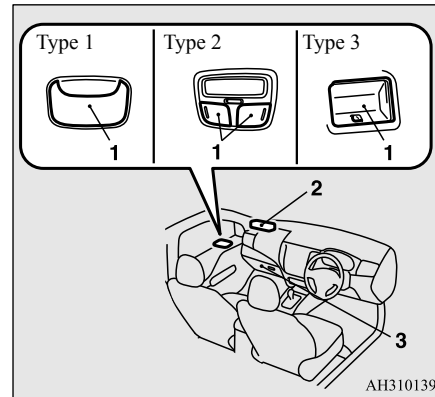

AH3101398

- 1- Type 1  
Rear room lamp: 8 W  
Type 2  
Rear personal lamps: 8 W  
Type 3  
Room lamp: 8 W
- 2- Front room & map lamps\*: 7.5 W
- 3- Glove box lamp: 1.4 W

## Headlamps

E01003502747

### Vehicles with halogen headlamps

#### ■ [Low beam]

1. When replacing the bulb on the right side of the vehicle, remove the clamps (A) of the air cleaner filter and move the upper cover (B) towards the rear of the vehicle.

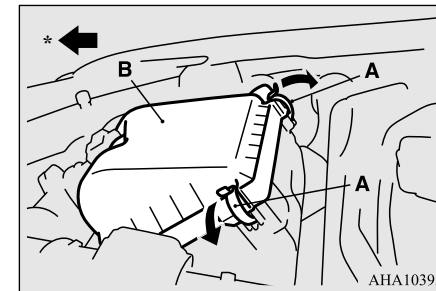

AHA103954

\*: Front of the vehicle

**NOTE**

- When moving the upper cover towards the rear of the vehicle, remove the harness from the air cleaner hooks (C).

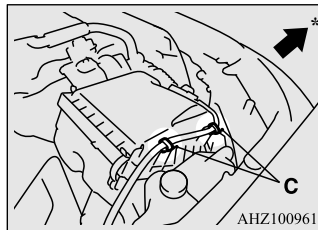

\*: Front of the vehicle

- After replacing the bulb, make sure that the hinges at the front of the vehicle are firmly set.

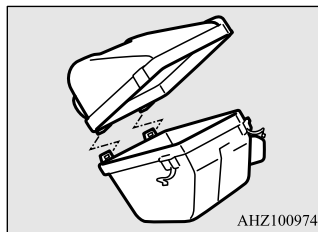

2. When replacing the bulb on the left side of the vehicle, remove the fuse block cover with pushing the tab (D).

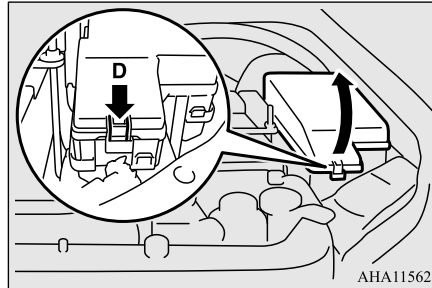

3. Turn the cover (E) anticlockwise to remove it.

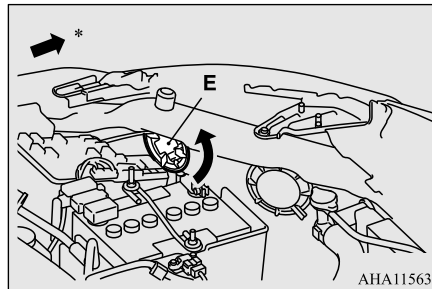

\*: Front of the vehicle

4. While holding down the tab (F), pull out the socket (G) from the bulb, and turn the bulb anticlockwise to remove it.

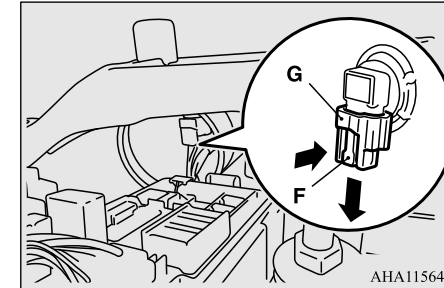

5. To install the bulb, perform the removal steps in reverse.

■ [High beam]

1. When replacing the bulb on the right side of the vehicle, remove the clamps (A) of the air cleaner filter and move the upper cover (B) towards the rear of the vehicle.

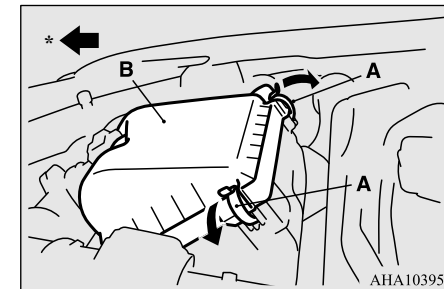

\*: Front of the vehicle

## Replacement of lamp bulbs

### NOTE

- When moving the upper cover towards the rear of the vehicle, remove the harness from the air cleaner hooks (C).

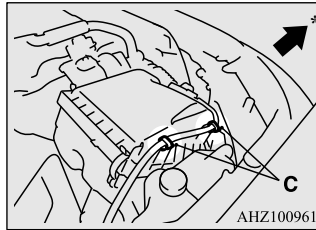

\*: Front of the vehicle

- After replacing the bulb, make sure that the hinges at the front of the vehicle are firmly set.

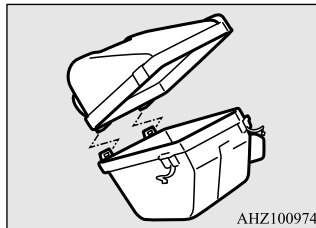

2. When replacing the bulb on the left side of the vehicle, remove the clip (D) holding down the washer tank spout and move the spout towards the rear of the vehicle.

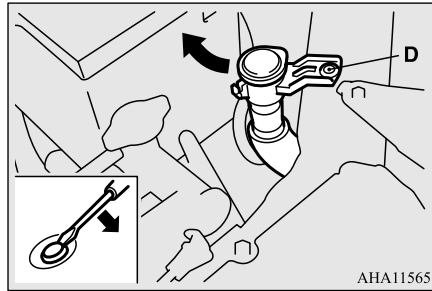

3. Turn the cover (E) anticlockwise to remove it.

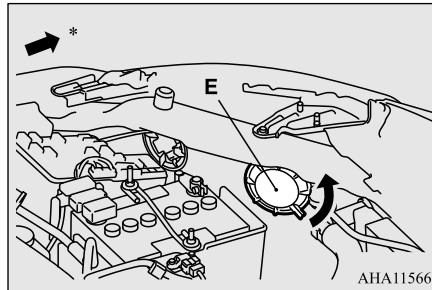

\*: Front of the vehicle

4. While pulling up the tab (F), pull out the socket (G) from the bulb, and turn the bulb anticlockwise to remove it.

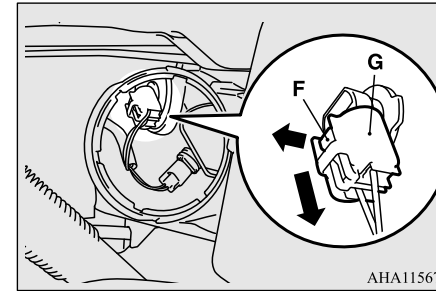

5. To install the bulb, perform the removal steps in reverse.

### Position lamps

E01003702749

### Vehicles with halogen headlamps

1. When replacing the bulb on the right side of the vehicle, remove the clamps (A) of the air cleaner filter and move the upper cover (B) towards the rear of the vehicle.

## Replacement of lamp bulbs

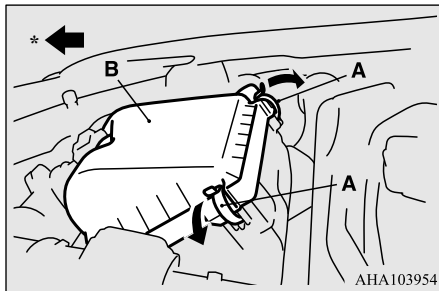

\*: Front of the vehicle

### NOTE

- After replacing the bulb, make sure that the hinges at the front of the vehicle are firmly set.

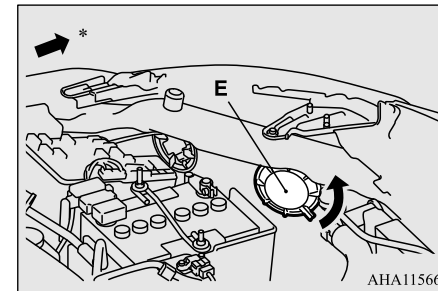
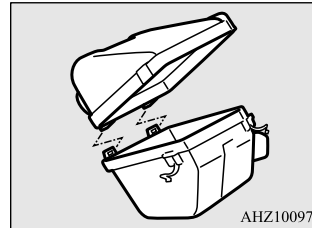

\*: Front of the vehicle

### NOTE

- When moving the upper cover towards the rear of the vehicle, remove the harness from the air cleaner hooks (C).

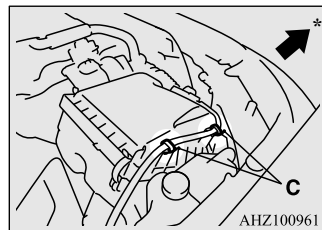

\*: Front of the vehicle

2. When replacing the bulb on the left side of the vehicle, remove the clip (D) holding down the washer tank spout and move the spout towards the rear of the vehicle.

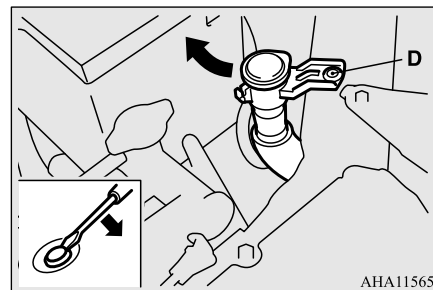

3. Turn the cover (E) anticlockwise to remove it.

4. Turn the bulb socket (F) anticlockwise to remove it. And remove the bulb from the socket by pulling out.

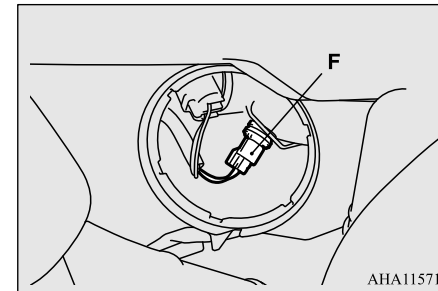

5. To install the bulb, perform the removal steps in reverse.

10

## Replacement of lamp bulbs

### Front turn-signal lamps

E01003802708

1. To create enough work space, turn the steering wheel all the way in the direction opposite to the side you wish to replace.
2. Remove the 3 bolts (A) and 1 clip (B), and then pull back the splash shield (C).

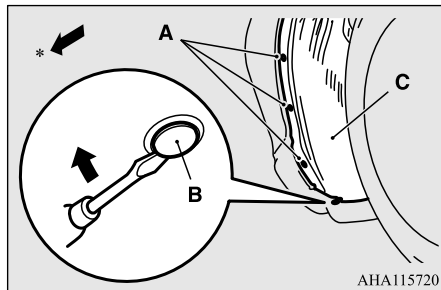

10

\*: Front of the vehicle

3. Turn the bulb socket (D) anticlockwise to remove it. And remove the bulb from the socket by turning it anticlockwise while pressing in.

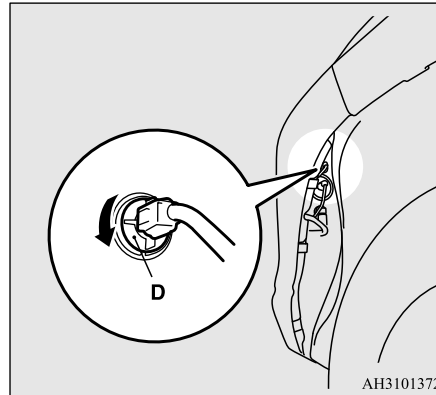

4. To install the bulb, perform the removal steps in reverse.

### NOTE

- When refitting the clip (B), first insert part (E) of the clip into the hole and then press part (F) into it.

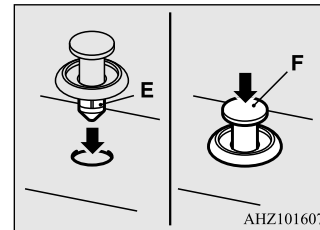

### Front fog lamps/Daytime running lamps\*

E01004003850

### Vehicles with halogen headlamps

1. To create enough work space, turn the steering wheel all the way in the direction opposite to the side you wish to replace.
2. Remove the 3 bolts (A) and 1 clip (B), and then pull back the splash shield (C).

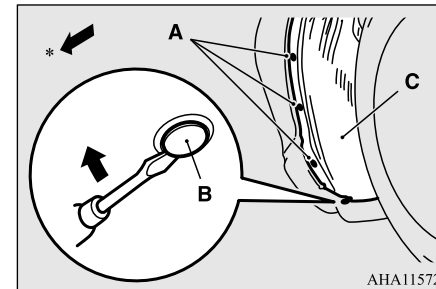

\*: Front of the vehicle

3. Confirm the position of the bulb to be replaced.

## Replacement of lamp bulbs

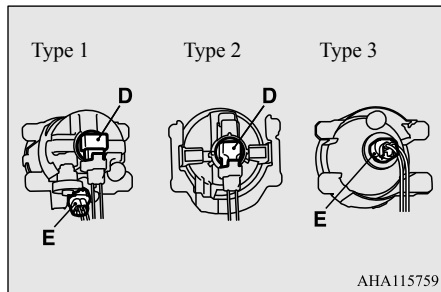

D- Front fog lamp  
E- Daytime running lamp

4. While holding down the tab (F), pull out the socket (G) from the bulb, and turn the bulb anticlockwise to remove it.

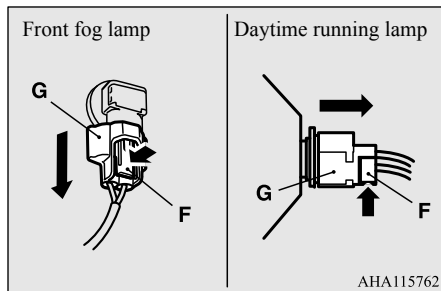

5. To install the bulb, perform the removal steps in reverse.

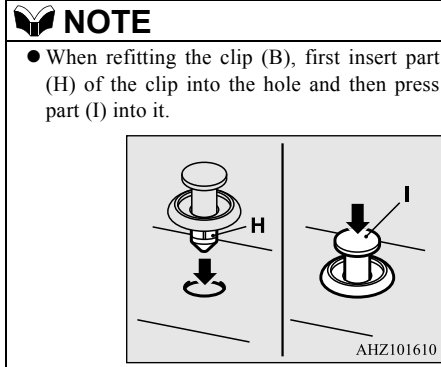

## Vehicles with LED headlamps

1. To create enough work space, turn the steering wheel all the way in the direction opposite to the side you wish to replace.
2. Remove the 3 bolts (A) and 1 clip (B), and then pull back the splash shield (C).

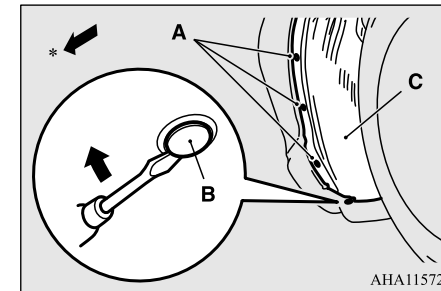

\*: Front of the vehicle

3. Confirm the position of the bulb to be replaced.

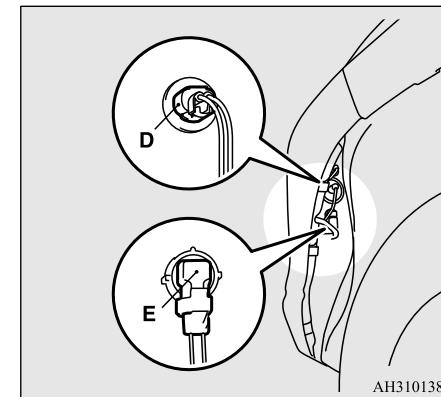

D- Daytime running lamp  
E- Front fog lamp

10



## Replacement of lamp bulbs

### 4. [Daytime running lamp]

Turn the socket (D) anticlockwise to remove it, and while holding down the tab (F), pull out the bulb (G) from the socket.

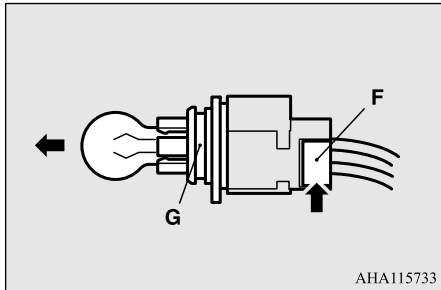

**10**

### [Front fog lamp]

While holding down the tab (H), pull out the socket (I) from the bulb, and turn the bulb anticlockwise to remove it.

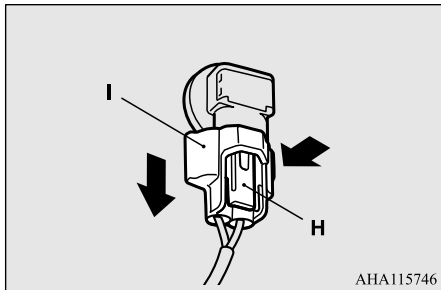

5. To install the bulb, perform the removal steps in reverse.

### NOTE

- When refitting the clip (B), first insert part (J) of the clip into the hole and then press part (K) into it.

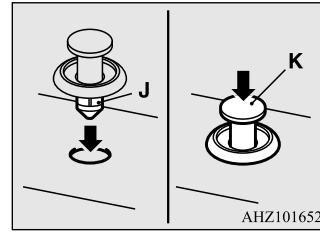

## Rear combination lamps

E01004203038

- Open the rear gate.  
(Refer to "Rear gate" on page 3-19.)
- Remove the screws (A) that hold the lamp unit.

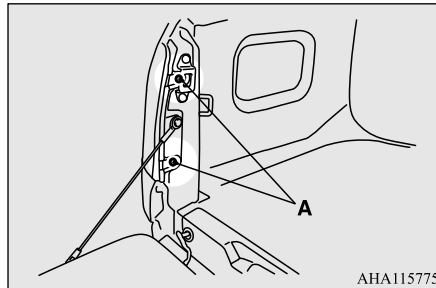

3. Move the lamp unit toward the rear of the vehicle and remove the clips (B).

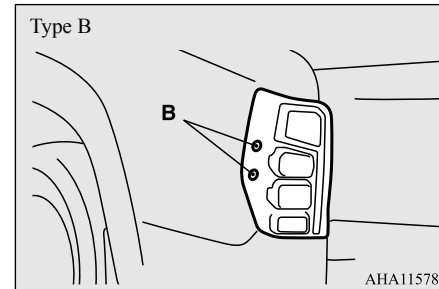
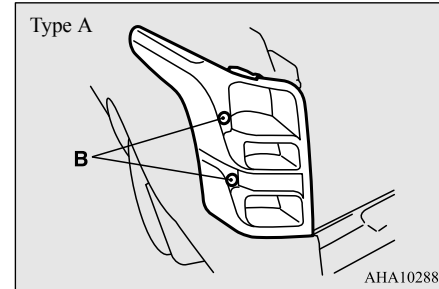

4. Remove each socket and bulb assembly by turning it anticlockwise.

## Replacement of lamp bulbs

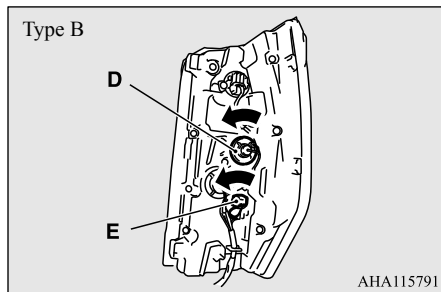
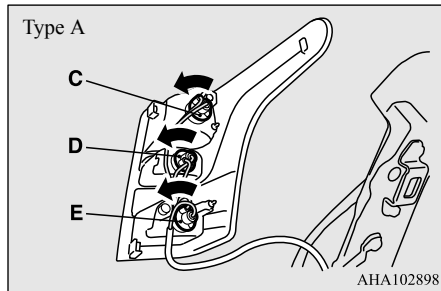

- C- Tail and stop lamp (Type A only)  
Remove the bulb from the socket by turning it anticlockwise while pressing in.
- D- Rear turn-signal lamp  
Remove the bulb by pulling it out.
- E- Reversing lamp  
Remove the bulb by pulling it out.

5. To install the bulb, perform the removal steps in reverse.

### NOTE

- When mounting the lamp unit for Type A, align the pins (F) and clip (G) on the lamp unit with the holes (H) in the body.

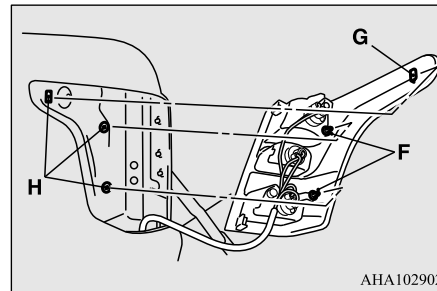

### Licence plate lamps

E01004602383

1. Insert a straight blade (or minus) screwdriver into the lamp assembly and pry gently to remove it.

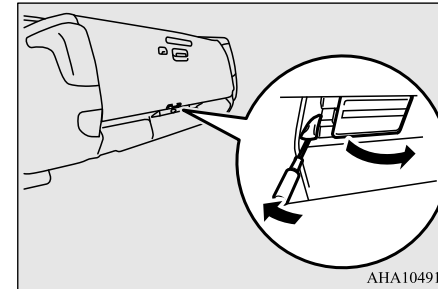

### NOTE

- Wrap a piece of cloth around the tip of the screwdriver in order to avoid scratching the lens and the body.
- Some models have two licence plate lamps.

2. Remove the socket and bulb assembly together by turning it anticlockwise, and then remove the bulb by pulling out.

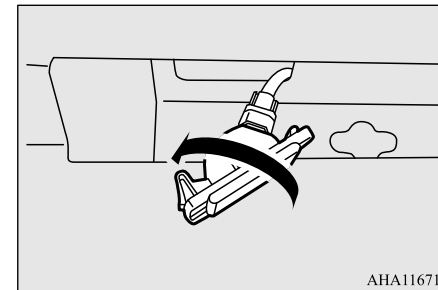

10

## Replacement of lamp bulbs

3. To install the bulb, perform the removal steps in reverse.

### NOTE

- When mounting the lamp unit, put the hook (A) on the right side of the lamp unit into the body first.

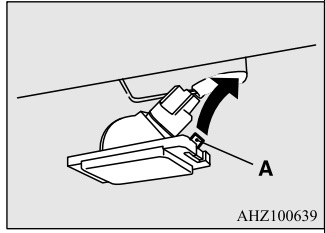

## 10

### Front room & map lamps\*

E01010501087

1. Insert a straight blade (or minus) screwdriver into the notch of the lens and pry gently to remove it.  
Remove the bulb from the lamp holder.

### Except for vehicles with rear circulator

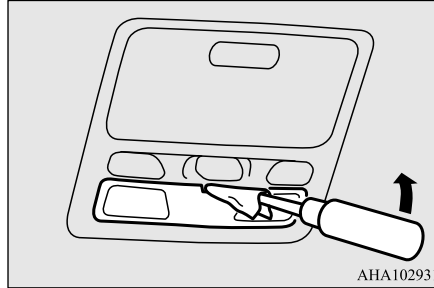

### Vehicles with rear circulator

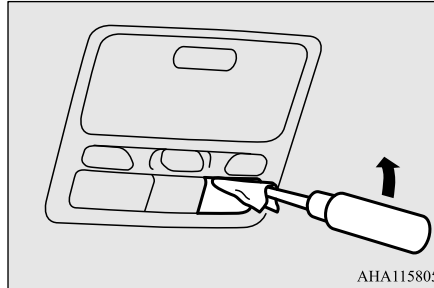

### NOTE

- Wrap a piece of cloth around the tip of the screwdriver in order to avoid scratching the lens.

2. To install the bulb, perform the removal steps in reverse.

### NOTE

- When installing the lens, align the tab (A) on the lens with the holes on the vehicle side.

### Except for vehicles with rear circulator

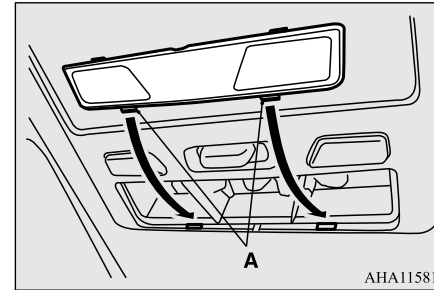

### Vehicles with rear circulator

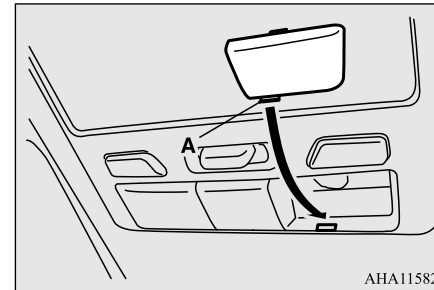

**Rear room lamp (Type 1), Rear personal lamps (Type 2), Room lamp (Type 3)**

E01004901523

**Type 1, Type 2**

1. Insert a straight blade (or minus) screwdriver into the notch of the lens and pry gently to remove it. Remove the bulb from the lamp holder.

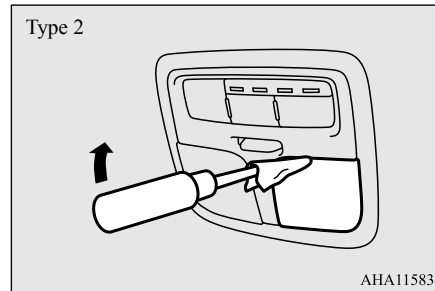
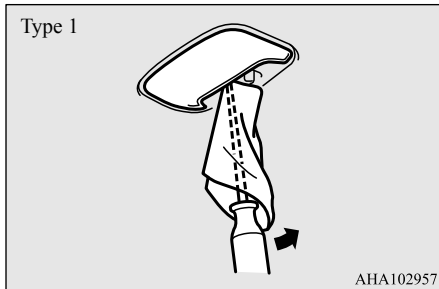

**NOTE**

- Wrap a piece of cloth around the tip of the screwdriver in order to avoid scratching the lens.

2. To install the bulb, perform the removal steps in reverse.

**NOTE**

- When installing the lens, align the tab (A) on the lens with the holes on the vehicle side.

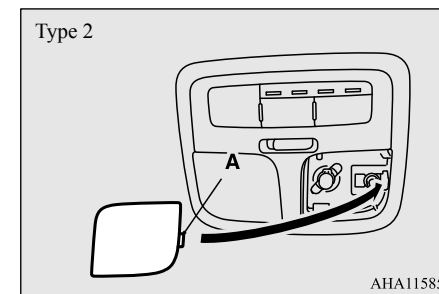
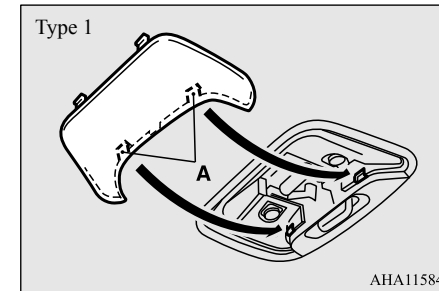

10

**Type 3**

1. Insert a straight blade (or minus) screwdriver into the notch of the lens and pry gently to remove it. Remove the bulb from the lamp holder.

## Replacement of lamp bulbs

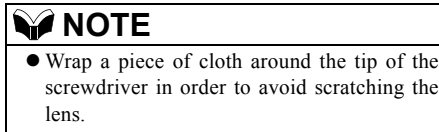
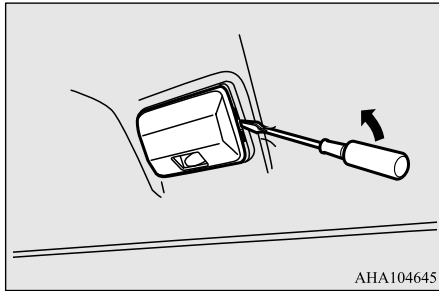

**10**

2. To install the bulb, perform the removal steps in reverse.

### **NOTE**

- When installing the lens, fit the two tabs on one side of the lens into the holes on the vehicle side before fitting the two tabs on the opposite side of the lens into the holes on the vehicle side.

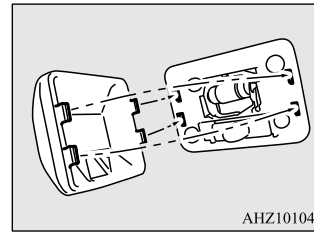

### **Glove box lamp**

E01006101499

Have the glove box lamp bulb replaced at an authorised MITSUBISHI MOTORS dealer.

## *Specifications*

Vehicle labelling .....	11-2
Vehicle dimensions .....	11-3
Vehicle performance .....	11-9
Engine specifications .....	11-12
Electrical system .....	11-12
Tyres and wheels .....	11-13
Capacity .....	11-13

## Vehicle labelling

### Vehicle labelling

E01100105614

### Vehicle Identification Number: (VIN)

The vehicle identification number is stamped as shown in the illustration.

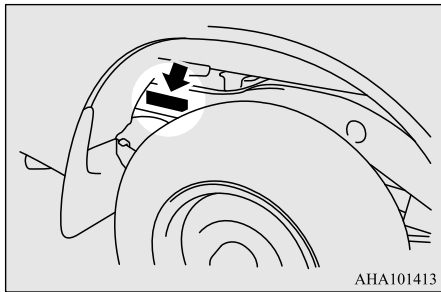

11

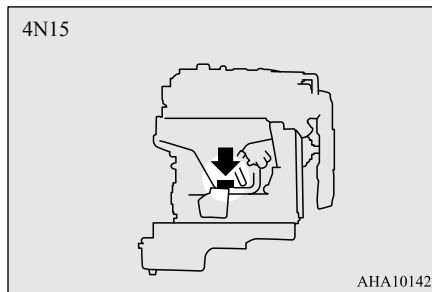
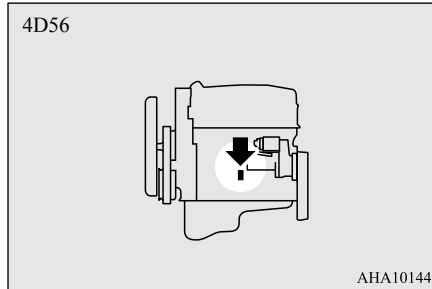

### Engine model/number

The engine model and number are stamped on the engine cylinder block as shown in the illustrations.

Vehicle dimensions

E01100205426

Single cab

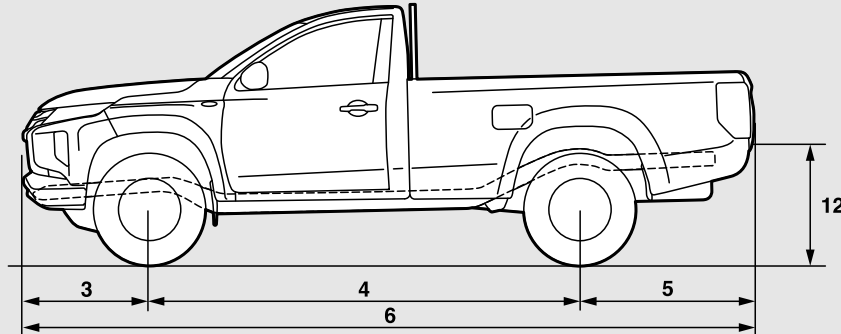
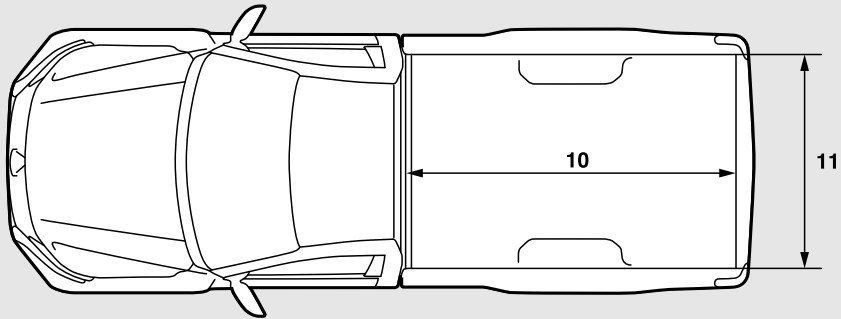
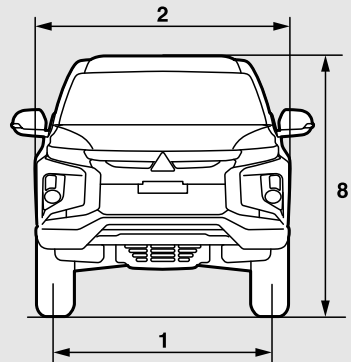
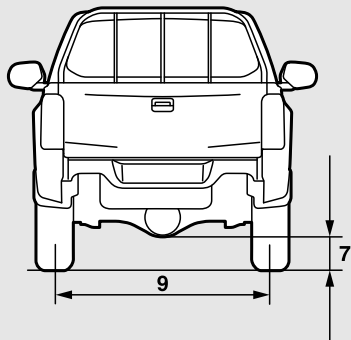

11

AH5106401



Vehicle dimensions

**Single cab**

Item		2WD	4WD
1	Front track	1,520 mm	
2	Overall width	1,815 mm	
3	Front overhang	880 mm	
4	Wheel base	3,000 mm, 2,800 mm* <sup>1</sup>	
5	Rear overhang	1,215 mm, 1,295 mm* <sup>2</sup>	
6	Overall length	5,095 mm	5,095 mm, 4,895 mm* <sup>1</sup> , 5,175 mm* <sup>2</sup>
7	Ground clearance (unladen)	200 mm	
8	Overall height (unladen)	1,655 mm	1,780 mm
9	Rear track	1,515 mm	
10	Cargo bed length	2,265 mm, 2,070 mm* <sup>1</sup>	
11	Cargo bed width	1,470 mm	
12	Cargo bed height	710 mm	845 mm, 840 mm* <sup>1</sup>

11

**Minimum turning radius**

Item	2WD	4WD
Body	6.1 m	6.3 m, 6.0 m* <sup>1</sup>
Wheel	5.7 m	5.9 m, 5.6 m* <sup>1</sup>

\*<sup>1</sup>:Short wheel base vehicles.

\*<sup>2</sup>:Vehicles with rear bumper.

Club cab

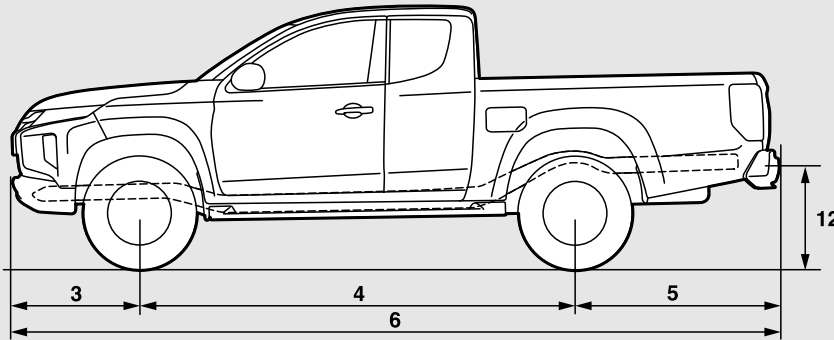
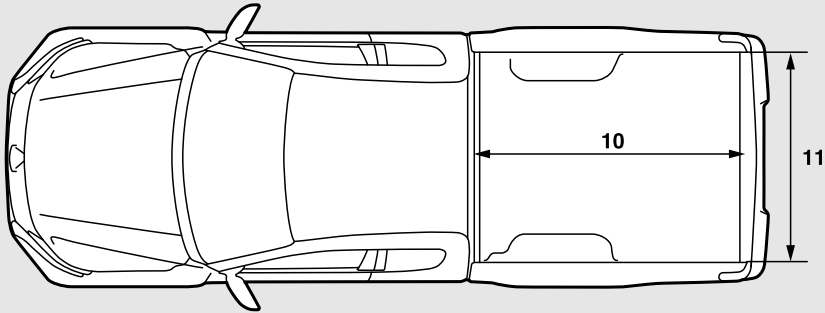
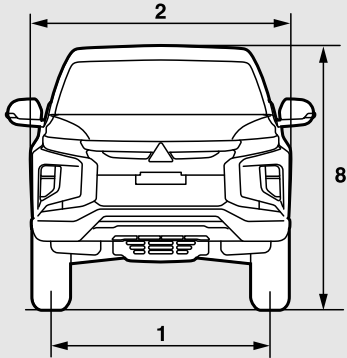
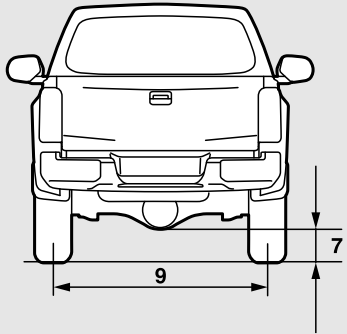

11

AH5106414

Vehicle dimensions

**Club cab**

Item		2WD	2WD Hi-Rider
1	Front track	1,520 mm	
2	Overall width	1,815 mm	
3	Front overhang	880 mm	
4	Wheel base	3,000 mm	
5	Rear overhang	Without rear bumper	1,330 mm
		With rear bumper	1,410 mm
6	Overall length	Without rear bumper	5,210 mm
		With rear bumper	5,290 mm
7	Ground clearance (unladen)	200 mm	205 mm, 220 mm*
8	Overall height (unladen)	1,655 mm	1,780 mm, 1,795 mm*
9	Rear track	1,515 mm	
10	Cargo bed length	1,850 mm	
11	Cargo bed width	1,470 mm	
12	Cargo bed height	715 mm	850 mm, 865 mm*

11

**Minimum turning radius**

Item	2WD	2WD Hi-Rider
Body	6.1 m	6.3 m
Wheel	5.7 m	5.9 m

\*:Vehicles with 18 inch tyre

Vehicle dimensions

Double cab

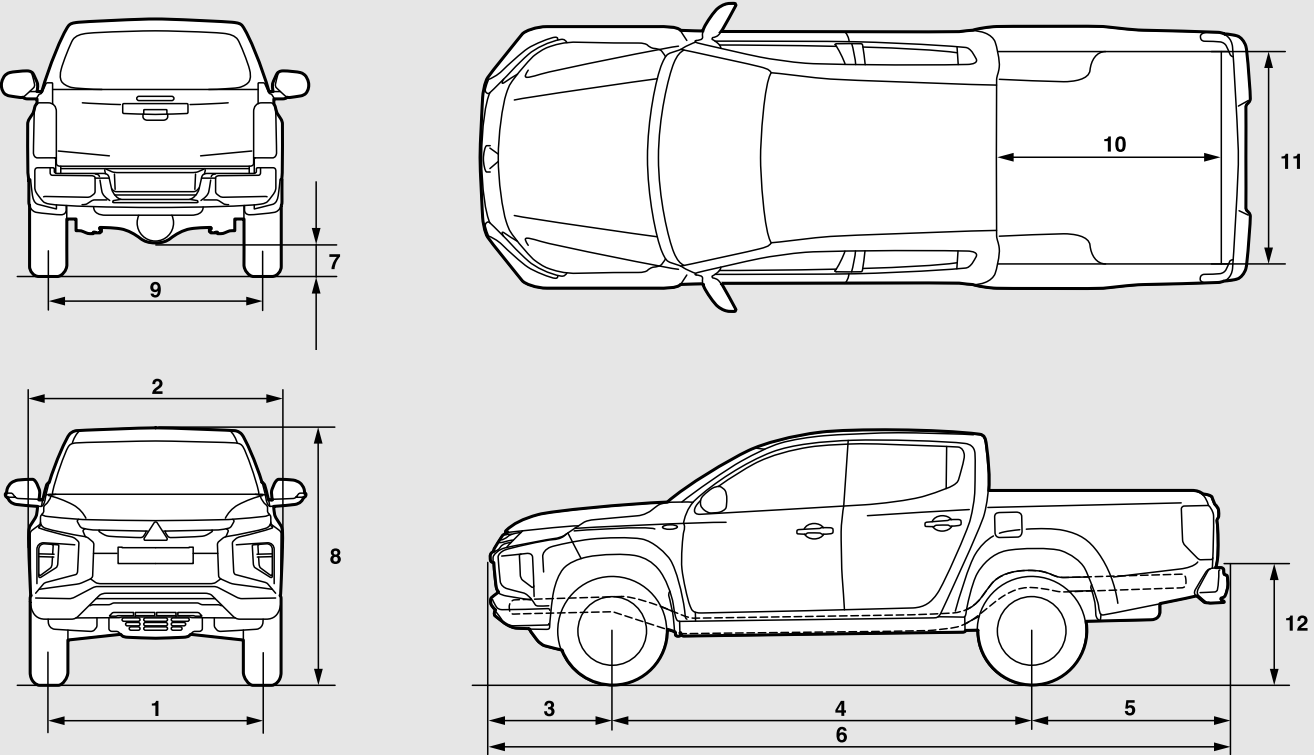

11

AH5106427

Vehicle dimensions

**Double cab**

Item		2WD	2WD Hi-Rider	4WD
1	Front track	1,520 mm		1,520 mm
2	Overall width	1,815 mm		1,815 mm
3	Front overhang	880 mm		880 mm
4	Wheel base	3,000 mm		3,000 mm
5	Rear overhang	Without rear bumper	1,340 mm	
		With rear bumper	–	1,420 mm
6	Overall length	Without rear bumper	5,220 mm	
		With rear bumper	–	5,300 mm
7	Ground clearance (unladen)	200 mm	205 mm, 220 mm*	220 mm
8	Overall height (unladen)	1,655 mm	1,780 mm, 1,795 mm*	1,795 mm
9	Rear track	1,515 mm		1,515 mm
10	Cargo bed length	1,520 mm		1,520 mm
11	Cargo bed width	1,470 mm		1,470 mm
12	Cargo bed height	715 mm	850 mm, 865 mm*	865 mm

11

**Minimum turning radius**

Item	2WD	2WD Hi-Rider	4WD
Body	6.1 m	6.3 m	6.3 m
Wheel	5.7 m	5.9 m	5.9 m

\*:Vehicles with 18 inch tyre

**Vehicle performance**

E01100304387

**Single cab**

Item	2WD	4WD
Maximum speed	165 km/h	169 km/h

**Club cab**

Item	2WD	2WD Hi-Rider	
		M/T	A/T
Maximum speed	165 km/h	179 km/h	177 km/h

**Double cab**

Item	2WD	2WD Hi-Rider, 4WD	
		M/T	A/T
Maximum speed	165 km/h	179 km/h	177 km/h

## Engine specifications

### Engine specifications

E01100605097

Engine models	4D56	4N15
No. of cylinders	4 in line	4 in line
Total displacement	2,477 cc	2,442 cc
Bore	91.1 mm	86.0 mm
Stroke	95.0 mm	105.1 mm
Camshaft	Double overhead	Double overhead
Mixture preparation	Electronic direct injection	Electronic direct injection
Maximum output (EEC net)	94 kW/4,000 r/min	133 kW/3,500 r/min
Maximum torque (EEC net)	240 N•m/1,500 ~ 3,500 r/min	430 N•m/2,500 r/min

### Electrical system

E01100805060

11

Item	4D56	4N15		
		Vehicles without the Auto Stop & Go (AS&G) system		Vehicles with the Auto Stop & Go (AS&G) system
		Without generation control	With generation control	
Voltage		12 V		
Battery	Type (JIS)	95D31L(622CCA/159RC)		T-110 (818CCA/159RC)
Alternator capacity	95 A	90 A	95 A	95 A

#### NOTE

- The vehicles equipped with Auto Stop & Go (AS&G) system have a dedicated AS&G battery type.  
Use of a different battery could cause the battery to run down quickly or AS&G system not to operate normally.  
Please contact an authorised MITSUBISHI MOTORS dealer when replacing the battery.

**Tyres and wheels**

E01100905449

Tyre		195R15C 106/104R 8PR	205R16C 110/108R 8PR	225/65R16C 112/110R	245/70R16 111S RF	245/65R17 111S RF	265/60R18 110H
Wheel	Size	15x6J	16x6JJ	16x6J	16x7J, 16x7JJ	17x7 1/2J	18x7 1/2J
	Offset (Inset)	38 mm					

**NOTE**

- Contact your MITSUBISHI MOTORS dealer for details on the combination used on your vehicle.

**Capacity**

E01101308018

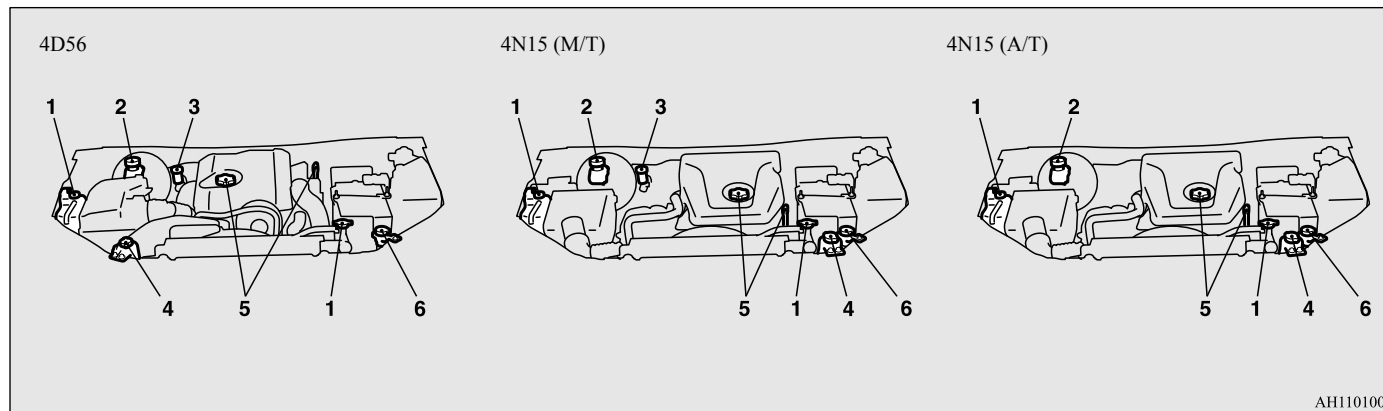

AH1101004



Capacity

No.	Item		Quantity	Lubricants	
1	Engine coolant [Includes 0.65 litre in the reserve tank]	4D56	8.2 litres	MITSUBISHI MOTORS GENUINE SUPER LONG LIFE COOLANT or equivalent	
		4N15	7.7 litres	MITSUBISHI MOTORS GENUINE SUPER LONG LIFE COOLANT PREMIUM or equivalent* <sup>1</sup>	
2	Brake fluid		As required	Brake fluid DOT3 or DOT4	
3	Clutch fluid		As required	Brake fluid DOT3 or DOT4	
4	Power steering fluid		As required	MITSUBISHI MOTORS GENUINE PSF (Power Steering Fluid)	
5	Engine oil	Oil pan	4D56	6.5 litres	Refer to page 10-5
			4N15	6.3 litres	
		Oil filter	4D56	0.8 litre	
			4N15	0.3 litre	
Oil cooler		0.1 litre			
6	Washer fluid		4.2 litres	—	
7	Automatic transmission fluid		10.4 litres	MITSUBISHI MOTORS GENUINE ATF-PA	

11

**CAUTION**

- For the Automatic transmission fluid, use only the MITSUBISHI MOTORS GENUINE ATF. Use of a different fluid could damage the transmission.

No.	Item			Quantity	Lubricants	
8	Manual transmission oil	2WD	5M/T	2.3 litres	MITSUBISHI MOTORS GENUINE MTF API GL-3 SAE 75W-85	
			6M/T	2.2 litres	MITSUBISHI MOTORS GENUINE NEW MULTI GEAR OIL ECO API GL-4, SAE 75W-80	
		4WD	6M/T	2.2 litres	MITSUBISHI MOTORS GENUINE NEW MULTI GEAR OIL ECO API GL-4, SAE 75W-80	
9	Transfer oil		6M/T, 6A/T	Super Select 4WD II	1.34 litres	MITSUBISHI MOTORS GENUINE NEW MULTI GEAR OIL ECO API GL-4, SAE 75W-80
				Easy Select 4WD	1.15 litres	
10	Differential oil	2WD		1.5 litres	MITSUBISHI MOTORS GENUINE Super Hypoid Gear Oil ECOLOGY API GL-5 SAE 80	
		2WD Hi-Rider		2.3 litres		
		4WD	Front	1.2 litres	MITSUBISHI MOTORS GENUINE Super Hypoid Gear Oil ECOLOGY API GL-5 SAE 80	
			Rear	2.3 litres	MITSUBISHI MOTORS GENUINE Super Hypoid Gear Oil ECOLOGY API GL-5 SAE 80	
11	Refrigerant (Air conditioning)			500-540 g, 530-570 g* <sup>2</sup>	HFC-134a	

\*<sup>1</sup>: Similar high quality ethylene glycol based non-silicate, non-amine, non-nitrate and non-borate coolant with long life hybrid organic acid technology

\*<sup>2</sup>: Vehicles with the Auto Stop & Go (AS&G) system



### Information for station service

Fuel	Capacity	Except for short wheel base vehicles	75 litres
		Short wheel base vehicles	68 litres
	Recommended fuel	Cetane number (EN590) 51 or higher Refer to the “General information” section for the fuel selection.	
Engine oil		Refer to the “Maintenance” section for the selection of engine oil.	
Tyre inflation pressure		Refer to the “Maintenance” section for the tyre inflation pressure.	